



OPERATING MANUAL

FORTENS

H6.0FT, H7.0FT (L006)

DO NOT REMOVE THIS MANUAL FROM THIS UNIT



LIFT TRUCK MODEL_____

SERIAL NUMBER_____

ENGINE MODEL_____

SERIAL NUMBER_____

TRANSMISSION TYPE_____

SERIAL NUMBER_____

MAST LIFT HEIGHT_____

GROUP NUMBER_____

CARRIAGE TYPE_____



GROUP NUMBER_____

DRIVE TIRE SIZE_____

STEERING TIRE SIZE_____

SPECIAL EQUIPMENT OR ATTACHMENTS

© Hyster Company 2018. All Rights Reserved.

HYSTER, , FORTENS, and MONOTROL are Registered Trademarks of Hyster-Yale Group, Inc. DURAMATCH, UNISOURCE, and  are Trademarks in the United States and certain other jurisdictions.



HYSTER

Foreword

Foreword

To OWNERS, USERS, and OPERATORS:

The safe and efficient operation of a lift truck requires skill and alertness on the part of the operator. To develop the skill required, the operator must:

- Receive training in the proper operation of THIS lift truck.
- Understand the capabilities and limitations of the lift truck.
- Become familiar with the construction of the lift truck and see that it is maintained in good condition.
- Read and properly understand the warnings, instructions, and operating procedures in this manual.

In addition, a qualified person, experienced in lift truck operation, must guide a new operator through several driving and load handling operations before the new operator attempts to operate the lift truck alone.

It is the responsibility of the employer to make sure that the operator can see, hear, and has the physical and mental ability to operate the equipment safely.

NOTE: A comprehensive operator training program is available from **Hyster Company**. For further details, contact your dealer for **Hyster** lift trucks.

This **Operating Manual** is the original instruction and contains information necessary for the operation and maintenance of a basic fork lift truck. Optional equipment is sometimes installed that can change some operating characteristics described in this manual. Make sure the necessary instructions are available and understood before operating the lift truck.

Some of the components and systems described in this **Operating Manual** will **NOT** be installed on your unit. If you have a question about any item described, contact your dealer for **Hyster** lift trucks.

The following additional information is provided as specified in Machinery Directive 98/37 EEC and/or 2006/42/EC:

- **Dimensional Details:** Certain information is shown on the lift truck Nameplate. For additional dimensional details on this or any other specific truck, consult your dealer.



Foreword

HYSTER

- **Noise Levels. Note:** The directive legally requires this information. The values have been calculated from the acoustic power levels for lifting and driving only and are only used for comparable value for different trucks. Higher or lower noise emissions can exist during operation of the truck, for example due to type of operation, environmental influences, and additional noise source outside of the truck.

In accordance with standards EN 12053 and EN ISO 4871, the equivalent sound pressure level (L_{paz}) at the operator position is in the range of:

- GM 4.3L — 79.0 - 80.0 db(A)
- PSI 4.3L — 79.0 — 80.0 db (A)
- Kubota 3.8L Diesel — 79.0 db(A)
- Kubota 3.6L Diesel — 80.0 db(A)

- **Human Vibration (Whole-Body and Hand-Arm Vibration). Note:** The whole-body vibration level is measured according to standard EN 13059 which contains specific test criteria (load, speed, roadway surface, etc.) Work-site vibration levels may vary depending on actual operating and surface conditions.

Whole-body vibration:

- Measured whole body vibration at the operator position, based on standard production truck with full-suspension seat is listed below.
- Declared whole-body vibration emission value is in accordance with EN 12096.
- Measured vibration emission value $a_{w,z} = 0.6 \text{ m/s}^2$
- Uncertainty, $K = 0.2 \text{ m/s}^2$
- Values determined according to EN 13059.

Hand-arm vibration:

- Hand-arm vibration emission value = $<2.5 \text{ m/s}^2$
- **Hazardous Atmosphere:** Before any truck within the European Community can be operated in a Potentially Explosive Atmosphere, it is necessary that the truck is suitably converted for the application. Conversions should only be carried out by a **Hyster** approved supplier. Confirmation of the conversion can be made by referring to the truck Declaration of Conformity which will confirm compliance with European Directive 94/9/ce. If



HYSTER

Foreword

you are in doubt, please contact your **Hyster** dealer for assistance.

- **Manufacturer:** Hyster Europe, Centennial House, Building 4.5, Frimley Business Park, Frimley, Surrey GU16 7SG, United Kingdom
- **The EC Conformity:** Each lift truck ships with a unique EC Declaration of Conformity certificate. See the end of this section for a sample EC Declaration of Conformity certificate which complies with Machinery Directive 2006/42/EC.

CAUTION

Disposal of lubricants and fluids must meet local environmental regulations.

NOTE: Hyster lift trucks are not intended for use on public roads.

NOTE: The following symbols and words indicate safety information in this manual:

WARNING

Indicates a hazardous situation which, if not avoided, could result in death or serious injury.

CAUTION

Indicates a hazardous situation which, if not avoided, could result in minor or moderate injury and property damage.

On the lift truck, the WARNING symbol is on an orange background. The CAUTION symbol is on a yellow background.



Foreword

HYSTER

Atmospheric Conditions

This range of lift trucks is designed to work in the following atmospheric conditions:

Standard Construction	
Average ambient temperature for continuous duty:	+30°C
Maximum ambient temperature, short term with potentially reduced performance:	+49°C
Lowest ambient temperature for trucks intended for continuous use in normal indoor conditions:	+5°C
Lowest ambient temperature for trucks intended for short term use in normal outdoor conditions:	-20°C
Altitude:	Up to 2000m
Relative humidity:	From 30% to 95% (non-condensing)



HYSTER

Foreword

NOTE: For lift trucks operating under continuous heavy-duty, extreme high temperature or high humidity conditions, special equipment may be required. Contact your local **Hyster** dealer.

Lifting

When transporting the truck, should lifting be required, please use the points indicated on the truck by the hook symbols. Traction batteries should be removed and lifted separately by the lifting eyes on the battery box.



Truck Modification

Unauthorized truck modification is not permitted. To obtain authorization contact your **Hyster** dealer.

Only in the event that the truck manufacturer is no longer in business and there is no successor in the interest of the

business, the user may arrange for a modification or alteration to a powered industrial truck, provided, however, that the user shall:

1. Arrange for the modification or alteration to be designed, tested, and implemented by an engineer(s) expert in industry trucks and their safety;
2. Maintain a permanent record of the design, test(s), and implementation of the modification or alteration;
3. Approve and make appropriate changes to the capacity plate(s), decals, tags and instruction handbook;
4. Affix a permanent and readily visible label to the truck stating the manner in which the truck has been modified or altered together with the date of modification or alteration, and the name and address of the organization that accomplished the tasks.



Foreword



HYSTER



EC DECLARATION OF CONFORMITY

WE
HYSTER EUROPE
CENTENNIAL HOUSE
BUILDING 4.5
FRIMLEY BUSINESS PARK
FRIMLEY, SURRY GU16 7SG
UNITED KINGDOM

DECLARE UNDER OUR SOLE RESPONSIBILITY THAT THE MACHINE

CATEGORY: FORKLIFT IC ENGINE POWERED

TYPE _____

SERIAL NUMBER(S) _____

YEAR OF CONSTRUCTION _____

IS IN CONFORMITY WITH THE MACHINERY DIRECTIVE 2006/42/EC. COMPLIANCE WITH THIS DIRECTIVE IS ESTABLISHED BY MEETING THE TECHNICAL REQUIREMENTS OF THE RELEVANT STANDARDS, INCLUDING EN ISO 3691-1

OTHER APPLICABLE DIRECTIVES:

2014/30/EU - EMC EMISSIONS

2000/14/EC - SOUND POWER FOR IC ENGINED FORKLIFT AS AMMENDED

BY 2005/88/EC.

TYPICAL VALUE dB

GUARANTEED VALUE, dB

CONFORMITY ASSESSMENT PROCEDURE: INTERNAL CONTROL OF PRODUCTION AND RESULTS OBTAINED BY FOLLOWING TEST PROCEDURE TEP 361, IN LINE WITH THE REQUIREMENTS OF DIRECTIVE 2000/14/EC

TECHNICAL FILE CONTROLLED BY THE ENGINEERING MANAGER, HYSTER-YALE UK LIMITED/NEDERLAND B.V., CRAIGAVON, NORTHERN IRELAND/NIJMEGEN, THE NETHERLANDS.

NAME
POSITION

PLANT MANAGER
(BLOCK LETTERS)

SIGNATURE
DATE



HYSTER

Contents

		Contents	
Foreword	1	Parked Regeneration Request	48
TO OWNERS, USERS, AND OPERATORS:	1	Regeneration Level 2	48
ATMOSPHERIC CONDITIONS	4	Warning Level	50
LIFTING	5	Regeneration Level 3	50
TRUCK MODIFICATION	5	Service Level	50
Warning	11	Regeneration Level 4	50
Model Description	14	DIESEL EXHAUST FLUID (DEF)	51
GENERAL	16	Normal DEF	51
OPERATOR PROTECTION EQUIPMENT	17	Low DEF	52
NAMEPLATE	18	Empty DEF	53
SAFETY LABELS	19	Bad DEF Quality	54
DISPLAY SWITCH CLUSTER	25	OPERATOR CONTROLS	54
Display Switch Cluster – Right-Side Display Inputs .	25	AUXILIARY CONTROL LEVERS	74
Display Switch Cluster – LCD Screen and Warning		Operating Procedures	75
and Indicator Lights	32	GENERAL	75
DISPLAY, DIESEL PARTICULATE FILTER (DPF)	42	Know Your Lift Truck	75
Operator Interface	43	Stability and Center of Gravity	77
CAN Communication Lost	44	Capacity (Weight and Load Center)	78
Passive Regeneration Only	44	Impact Sensor	79
Regeneration Level 0	44	INSPECTION BEFORE OPERATION	80
Auto/Active Regeneration	45	Checks With the Engine Stopped	80
Auto/Active Regeneration	46	Operator Checklist	81
Regeneration Level 1	46	Mounting and Dismounting	82
Idle-up Auto/Active Regeneration	47	Lift Truck Interlocks	82



Contents

HYSTER

Operator Passwords	82	Load Handling, Emergency Load Lowering	114
Starting Procedures	84	HIGHWAY TRUCKS, RAIL CARS, AND DOCKS	116
Stop Procedures, Diesel Engine	85	ATTACHMENTS	117
Checks With the Engine Running	85	Disconnecting Attachment Hydraulic Quick-	
Load Weighing Sensor	86	Disconnect Hoses	117
Set Load Weight to Zero	87	Connecting Attachment Hydraulic Quick-Disconnect	
Engine Shutdown	87	Hoses	118
OPERATING TECHNIQUES	89	STOPPING	119
Basic Operating Procedures	89	PARKING	119
Driving and Direction Changes	94	Maintenance	121
General	96	GENERAL	121
Normal Operations	96	Serial Number Data	122
Standard Operator Presence System	97	HOW TO MOVE A DISABLED LIFT TRUCK	122
Optional Operator Presence System	98	How to Tow the Lift Truck	122
Powershift 2 Speed Transmission or Powershift		HOW TO PUT A LIFT TRUCK ON BLOCKS	124
Transmission	98	How to Raise the Drive Tires	124
DuraMatch, DuraMatch Plus, and Duramatch AH		How to Raise the Steering Tires	124
Transmissions	99	HOW TO CLEAN A LIFT TRUCK	126
Inching	101	Maintenance Schedule	126
Steering (Turning)	102	Maintenance Procedures Every 8 Hours or Daily	152
Load Handling, General	104	HOW TO MAKE CHECKS WITH THE ENGINE	
Load Handling, Lifting, Lowering, and Tilting	105	STOPPED	152
Load Handling, How to Engage and Disengage a		Tires and Wheels	152
Load	107	Safety Labels	153
Load Handling, Traveling	110		



HYSTER

Contents

Mast, Carriage, Header Hoses, Lift Chains, and Attachment	153	Brake Oil Level	180
Operator Restraint System	154	Operation, Check	181
Emergency Locking Retractor (ELR)	155	Parking Brake	181
Seat Plate and Seat Rails	156	Engine Oil Pressure	181
Engine Compartment	156	Cooling System	182
Paper Application	156	Steering System	184
Fuel, Oil, and Coolant Leaks, Check	158	Control Levers and Pedals	184
Hydraulic Hoses	158	Lift System Operation	184
Coolant Hoses	158	Air Filter	185
Steering Column Gas Cylinder	158	Fuel/Water Separator Filter, Kubota Diesel Engine .	186
Transmission	159	HOW TO ADD FUEL TO THE LIFT TRUCK	186
Hydraulic System Oil	159	Liquefied Petroleum Gas (LPG)	187
Engine Oil	160	LPG Tank, Removal	188
Air Filter	171	LPG Tank, Fill	190
Forks	171	LPG Tank, Install	190
Forks, Remove	171	Diesel Fuel	191
Forks, Inspect	174	Diesel Exhaust Fluid (DEF)	191
Forks, Install	175	Refilling DEF Tank	191
Forks, Adjust	175	Storage of DEF	192
Hang On Sideshift Carriage	176	WHEELS AND TIRES	192
HOW TO MAKE CHECKS WITH THE ENGINE		General	192
RUNNING	178	PNEUMATIC TIRE WITH TUBE, REPAIR	193
Indicator Lights, Horn, Fuses, and Relays	178	Remove Wheels From Lift Truck	193
Service Brakes	180	Remove Tire From Wheel	194
		Tire Removal, Two-Piece Wheel	196



Contents

HYSTER

Tire Removal, Three- and Four-Piece Wheels	197	JUMP-STARTING THE LIFT TRUCK	216
Install Wheel in Tire	198	Jump-Starting Using a Battery Charger	216
Tire Installation Three- or Four-Piece Wheel	199	Jump-Starting Using Another Lift Truck	217
Tire Installation Two-Piece Wheel	200	OPERATING PROCEDURES FOR A NEW OR	
Add Air to Pneumatic Tires With Tube	200	REBUILT ENGINE	217
Install the Wheels	201	CHANGES TO THE OVERHEAD GUARD	218
PNEUMATIC TUBELESS TIRE, REPAIR	202	HOW TO PUT INTERNAL COMBUSTION ENGINE	
Remove Tire From Lift Truck	202	(ICE) TRUCKS IN STORAGE	218
Remove Tire From Wheel	202	Short-Term Storage	218
Install Tire on Wheel	204	Long-Term Storage	219
Add Air to Pneumatic Tubeless Tire	207	While the Lift Truck is in Storage	220
Install the Wheels	208	How to Put Batteries in Storage	220
SOLID RUBBER TIRES ON PNEUMATIC WHEELS,		Putting a Stored Lift Truck Back Into Service	221
CHANGE	208	HOW TO MOVE A LIFT TRUCK ON A	
Remove Tire From Wheel	208	TRANSPORT	221
Install Tire on Wheel	210	Loading	221
DUAL DRIVE WHEELS, INSTALL	212	Unloading	223
SNAP-ON-TIRE, CHANGE	213	PREPARATION FOR USE	223
Remove Snap-On-Tire, Solid Tire From Wheel	215	Preparation After Transport	223
Install Snap-On-Tire, Solid Tire on Wheel	215	Maintenance Register	224



HYSTER

Warning

WARNING

**FAILURE TO FOLLOW THESE INSTRUCTIONS CAN CAUSE SERIOUS INJURY OR DEATH!
AUTHORIZED, TRAINED OPERATOR ONLY!**

KNOW THE EQUIPMENT:

- ALWAYS use 3 points of contact when getting on and off the truck.
- KNOW operating, inspection, and maintenance instructions in this **Operating Manual**.
- **DO NOT** operate or repair truck unless trained and authorized.
- INSPECT truck before use.
- **DO NOT** operate if truck needs repair. Tag truck and remove key. Repair truck before use. Always use **Hyster Approved** parts when making repairs. Replacement parts must meet or exceed the specifications of the original equipment manufacturer.
- USE auxiliary equipment (attachments) for intended purpose only.
- VERIFY truck is equipped with overhead guard and load backrest adequate for the load.

LOOK WHERE YOU ARE GOING:

- IF YOU CAN'T SEE, DON'T GO.
- TRAVEL in reverse if load blocks forward vision.
- MAKE SURE tail swing area is clear.
- SOUND horn at intersections or where vision is blocked.
- WATCH clearances, especially overhead.

KNOW YOUR LOADS:

- HANDLE only stable loads within specified weight and load center. See Nameplate on truck.
- DO NOT handle loose loads higher than load backrest.
- SPACE forks as far apart as load allows and center load between forks. Keep load against load backrest.



Warning

HYSTER

WARNING

**FAILURE TO FOLLOW THESE INSTRUCTIONS CAN CAUSE SERIOUS INJURY OR DEATH!
AUTHORIZED, TRAINED OPERATOR ONLY!**

USE COMMON SENSE:

- DO NOT use truck to lift people unless there is no other practical option. Then, use only a securely attached special work platform. Follow instructions in this Operating Manual.
- OBEY traffic rules. Yield right-of-way to pedestrians.
- BE in complete control at all times.
- ALLOW NO ONE under or near lift mechanism or load.
- OPERATE truck only from operator's seat.
- KEEP arms, legs, and head inside operator's compartment.
- DO NOT move truck if anyone is between truck and stationary object.
- BEFORE DISMOUNTING, neutralize travel control, lower carriage, and set brake.

- WHEN PARKING, also shut off power, close LPG fuel valve, block wheels on inclines.

KNOW THE AREA:

- NEVER enter a trailer or railroad car unless its wheels are blocked.
- CONFIRM floor strength.
- FILL fuel tank or charge battery only in designated area.
- TURN OFF engine when fueling.
- AVOID sparks or open flame. Provide ventilation.
- DO NOT start if fuel is leaking.
- KEEP vent caps clear when charging battery.
- DISCONNECT battery during servicing.
- CHECK dockboard width, capacity, and security.



HYSTER

Warning

WARNING

**FAILURE TO FOLLOW THESE INSTRUCTIONS CAN CAUSE SERIOUS INJURY OR DEATH!
AUTHORIZED, TRAINED OPERATOR ONLY!**

PROTECT YOURSELF FASTEN YOUR SEAT BELT!

- AVOID bumps, holes, and loose materials.
- AVOID sudden starts or stops.
- NEVER turn on or angle across an incline.
- TRAVEL on inclines with load uphill or when unloaded with lift mechanism downhill.
- TILT mast slowly and smoothly. LIFT or LOWER with upright vertical or tilted slightly back. Use minimum tilt when stacking elevated loads.

- TRAVEL with carriage as low as possible and tilted back.
- SLOW DOWN before turning, especially without load.

FAILURE TO FOLLOW THESE INSTRUCTIONS CAN CAUSE THE LIFT TRUCK TO TIP.

DO NOT JUMP off if the truck tips over. HOLD steering wheel firmly. BRACE your feet. LEAN FORWARD and AWAY from point of impact.

Model Description

HYSTER

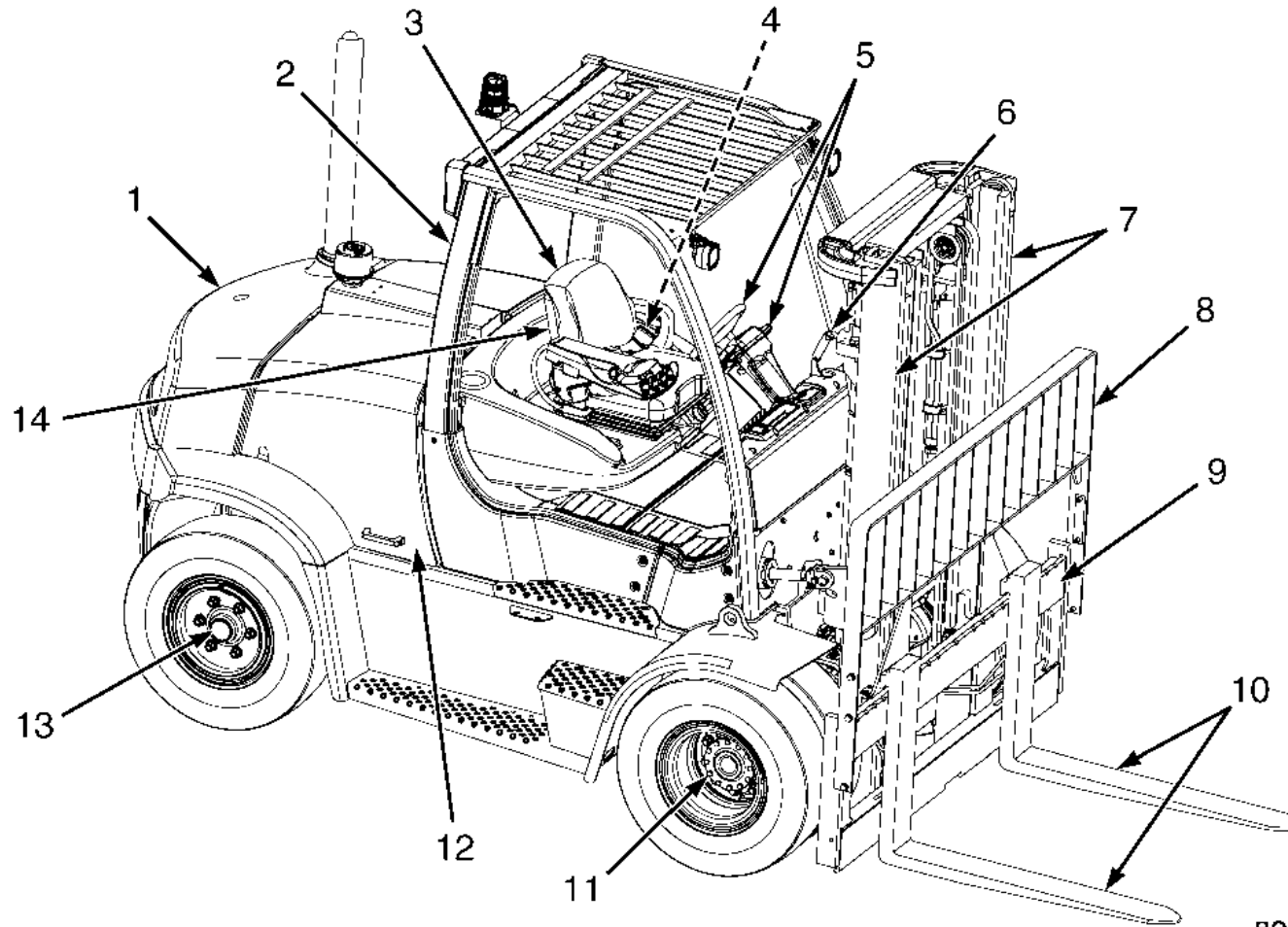

BO190893

Figure 1. Model View Showing Major Components



HYSTER

Model Description

Legend for Figure 1

- | | |
|--------------------------------|------------------------------------|
| 1. COUNTERWEIGHT | 8. LOAD BACKREST EXTENSION |
| 2. OVERHEAD GUARD | 9. CARRIAGE |
| 3. SEAT | 10. FORKS |
| 4. SEAT BELT AND HIP RESTRAINT | 11. DRIVE WHEELS |
| 5. STEERING WHEEL AND COLUMN | 12. HOOD |
| 6. PARKING BRAKE | 13. STEER WHEELS |
| 7. MAST | 14. OPERATING MANUAL (BEHIND SEAT) |



Model Description

HYSTER

Model Description

General

This **Operating Manual** is for the following models of lift trucks:

H6.0FT, H7.0FT (L006)

These lift trucks are available with the following engines:

- 4.3L LPG engine
- Kubota 3.8L diesel engine
- Kubota 3.6L diesel engine
- Kubota 3.8L 55kW diesel engine

These lift truck models can be equipped with either a Powershift 2 Speed Transmission, a DuraMatch Transmission (3-speed), a DuraMatch Plus Transmission (3-speed), a Powershift Transmission, a DuraMatch Transmission, or a DuraMatch AH Transmission and three types of controls:

- A MONOTROL® pedal that controls both the forward and reverse operation of the transmission and the speed of the engine

- A direction control lever on the left side of the Display Switch Cluster that controls the forward, neutral, and reverse operation of the transmission. A separate accelerator pedal controls the engine speed.
- A directional control switch integrated into the armrest on units equipped with E-Hydraulics. Controls both forward and reverse operation of the transmission. A separate accelerator pedal control engine speed.

The lift trucks covered in this manual are equipped with pneumatic tires or solid rubber tires that look like pneumatic tires. See **Wheels and Tires** in the **Maintenance Section** for a description of these tires.

The lift trucks covered in this manual can be equipped with either standard manual hydraulic levers or Electro-Hydraulic (E-Hydraulic) mini-levers. See **Figure 22**.

Trucks equipped with E-Hydraulics are equipped with a main control valve which incorporates an emergency lowering valve (see **Figure 27**). This valve allows the operator or service technician to lower the lift truck's mast assembly if the electrical signal to the main control valve is disrupted.



HYSTER

Model Description

See the **Load Handling, Emergency Load Lowering** section in the **Operating Procedures** section.

CAUTION

If the lift truck is equipped with a 3-stage mast, in circumstances where overhead clearance is restricted, be sure inner mast/carriage does not extend before full free lift of the mast is reached.

NOTE: Cold hydraulic oil and high oil flow rates may cause the inner mast to extend above the outer mast before full free lift is reached. The hydraulic oil must be hot if the lift truck is to be operated where overhead clearance is restricted.

To assure hydraulic oil is hot, operate mast at full lift speed and observe for movement of the inner mast before full free lift is reached. If any inner mast movement occurs, fully lower carriage, place the transmission into neutral, set the park brake, and then hold the tilt mini-lever fully open at engine governed speed for approximately 3 minutes.

Repeat above procedure until no movement of the inner mast is observed, then proceed with lift truck operation.

The lift trucks covered in this manual may be equipped with either a 2-stage limited freelif or a 3-stage full freelif mast.

Operator Protection Equipment

The LOAD BACKREST EXTENSION is installed to keep loose parts of the load from falling back toward the operator. It must be high enough, with vertical openings small enough, to prevent the parts of the load from falling backwards. If a load backrest extension that is different from the one installed on your lift truck is required, contact your **Hyster** lift truck dealer.

The OVERHEAD GUARD is intended to offer reasonable protection to the operator from falling objects, but cannot protect against every possible impact. Therefore, it must not be considered a substitute for good judgment and care when handling loads. Do not remove the overhead guard.

NOTE: The seat belt can be either black or red.

The SEAT BELT AND HIP RESTRAINT provide additional means to help the operator keep the head and torso substantially within the confines of the lift truck frame and overhead guard if a tipover occurs. This restraint system is intended to reduce the risk of the head and torso being trapped between the lift truck and the ground, but it cannot protect the operator against all possible injury in a tipover.



Model Description

HYSTER

The hip restraint will help the operator resist side movement. It is not a substitute for the seat belt. Always fasten the seat belt.

This lift truck is equipped with one of the three seat belt configurations.

- Seat belt with no operation interlock.
- Seat belt with operation interlock. Seat belt must be fastened for lift truck to start or to travel.
- Seat belt with sequencing interlock. Operator must be in the seat, then the seat belt fastened before lift truck will operate. This seat belt is used with the Optional Operator Presence System.

Nameplate

WARNING

DO NOT add to or modify the lift truck. Any modification that affects the safe operation of the truck cannot be undertaken without the written authorization of Hyster Company.

Any change to the lift truck, the tires, or its equipment can change the lifting capacity. The lift truck must be

rated as equipped and the Nameplate must show the new capacity rating.

The capacity is specified in kilograms (kg) and pounds (lb). The capacity is the maximum load that the lift truck can handle for the load condition shown on the Nameplate.

The maximum capacity for the lift truck, at full load height, must be shown on the Nameplate. Special capacities with the load height reduced or with optional load centers, may also be shown on the Nameplate.

NOTE: The image in **Figure 2** is a sample only. Reference the actual nameplate installed on the truck for actual truck specifications.

The lift truck serial number code is on the Nameplate. The serial number code is also stamped on the right-hand side of the lift truck frame, under the floorplate.

When a lift truck is shipped incomplete from the factory, the Nameplate is covered by an INCOMPLETE label as shown in **Figure 2**. If the equipment on the truck is changed, the Nameplate is covered by a NOTICE label as shown in **Figure 2**. If your lift truck has either of these labels, do not operate the lift truck. Contact your dealer for **Hyster** lift trucks to obtain a complete and correct Nameplate.



HYSTER

Model Description

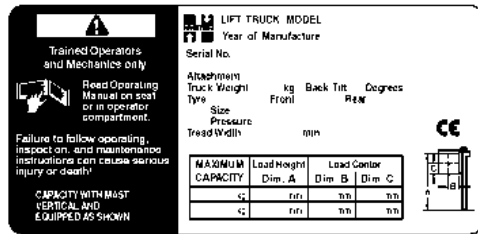

(A)



(B)

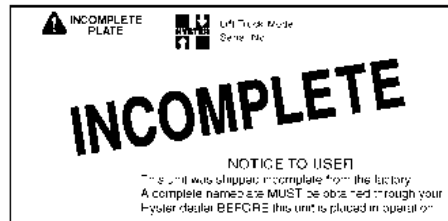

(C)

HO191243

- A. NAMEPLATE (CE NAMEPLATE SHOWN)
- B. NOTICE LABEL
- C. INCOMPLETE LABEL

Figure 2. Nameplate and Labels

Safety Labels

Safety labels are installed on the lift truck to provide information about possible hazards. It is important that all safety labels are installed on the lift truck and can be read. See Figure 3.

Model Description

HYSTER

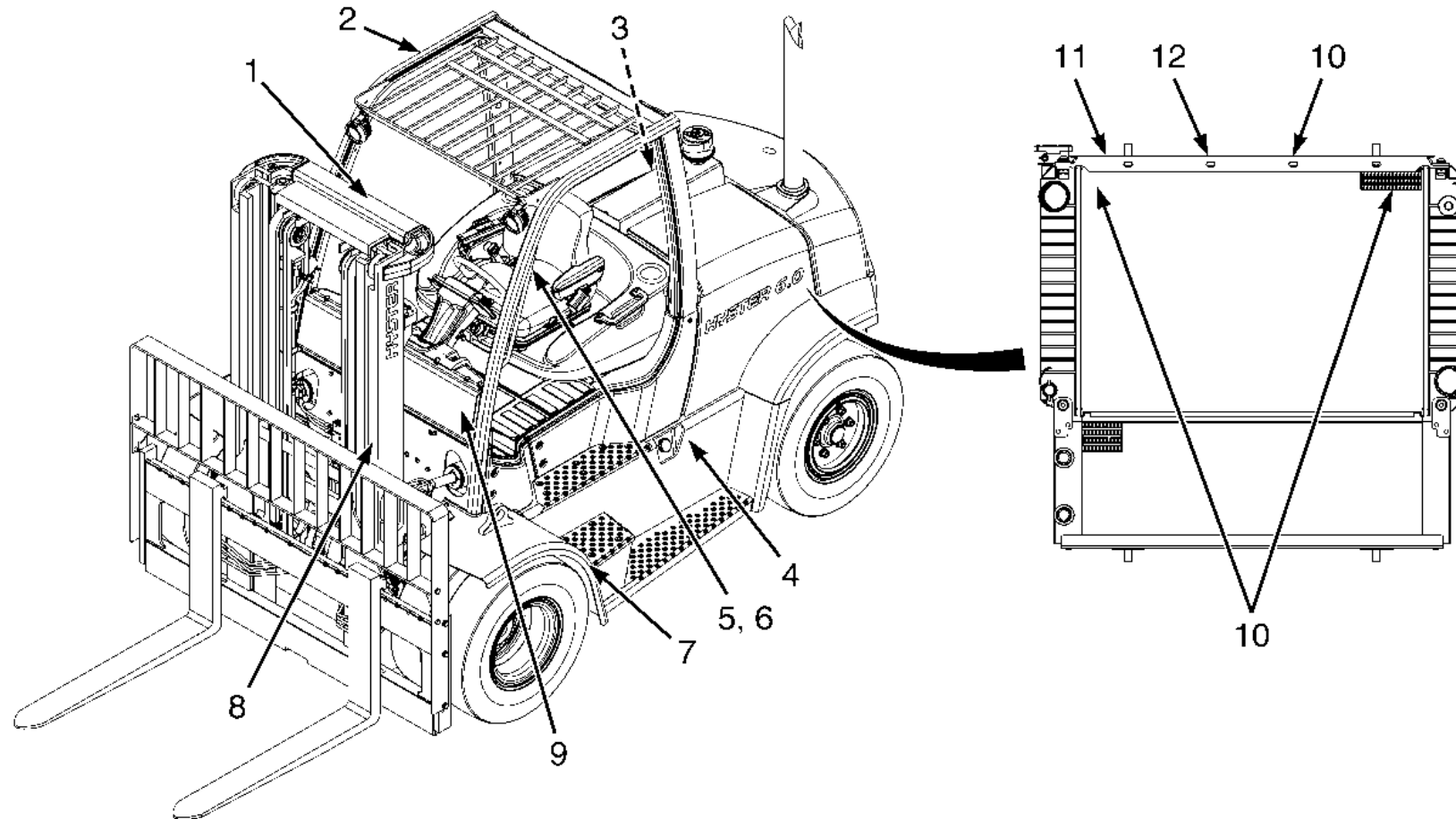

BO191541

Figure 3. Warning and Safety Labels (Sheet 1 of 5)

HYSTER

Model Description

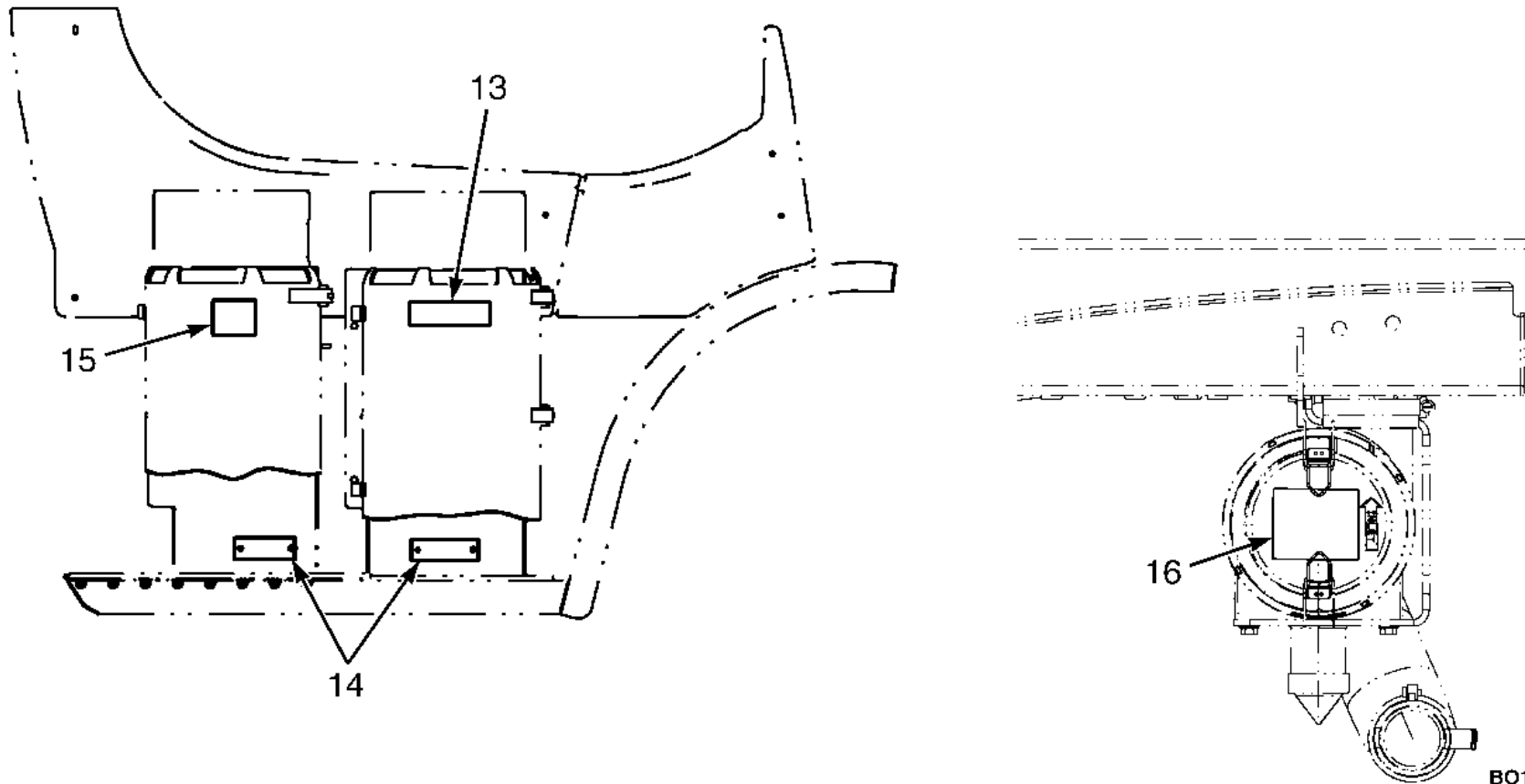
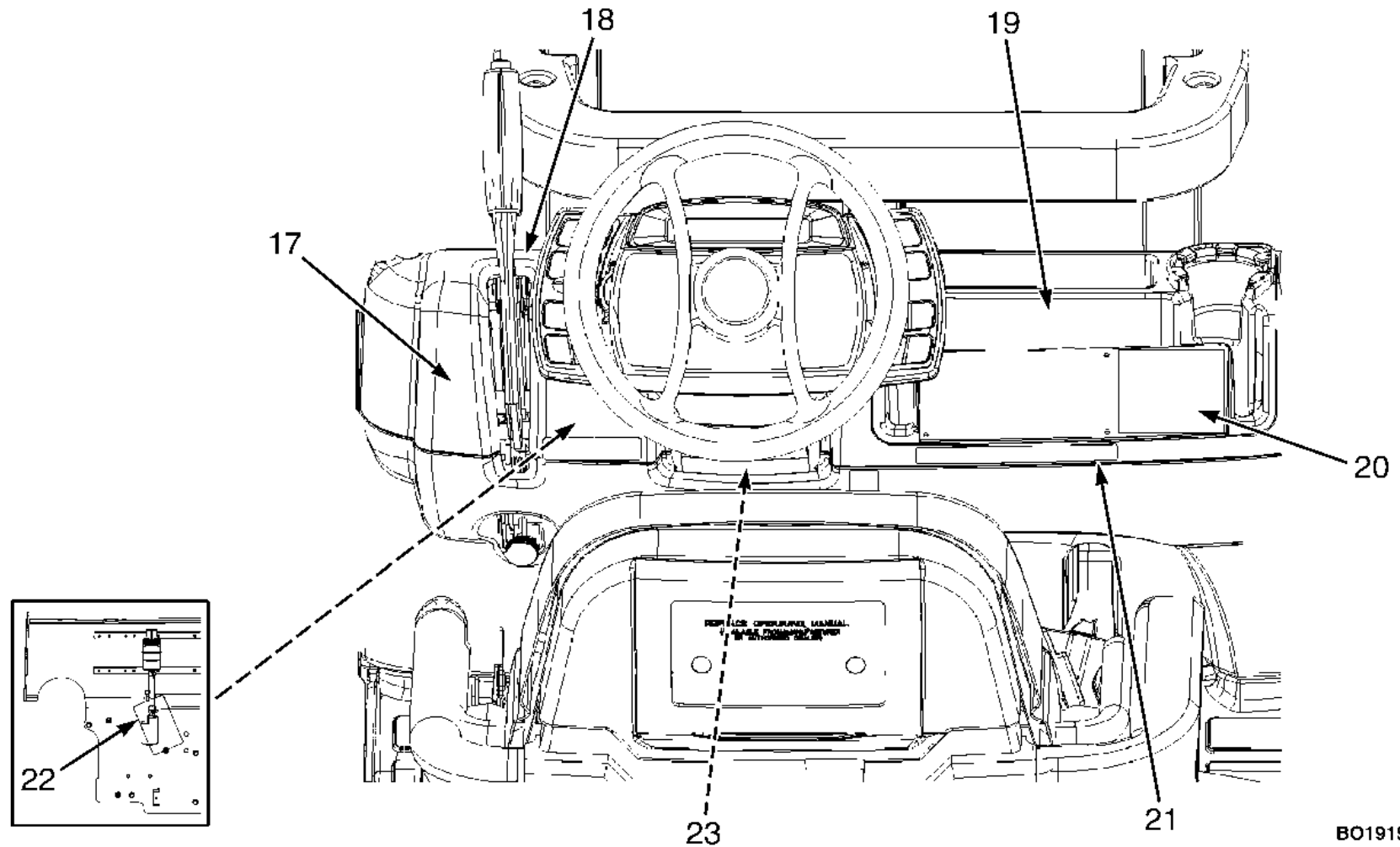

Figure 3. Warning and Safety Labels (Sheet 2 of 5)

Model Description

HYSTER



BO191543

Figure 3. Warning and Safety Labels (Sheet 3 of 5)



HYSTER

Model Description

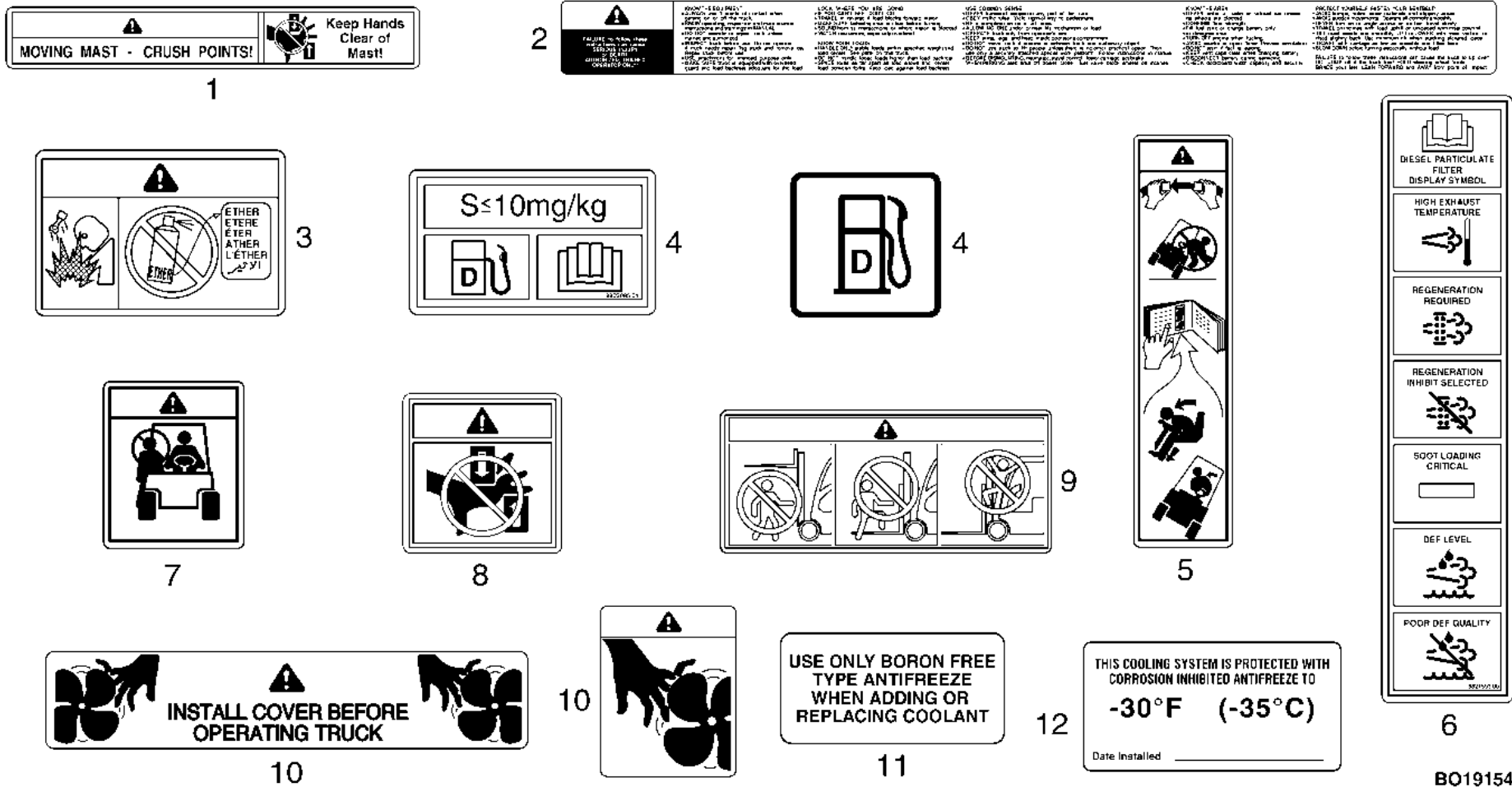
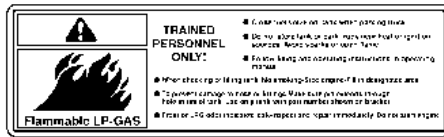

Figure 3. Warning and Safety Labels (Sheet 4 of 5)



Model Description

HYSTER



13

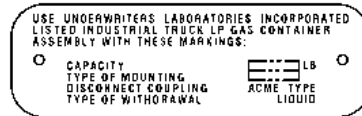

14

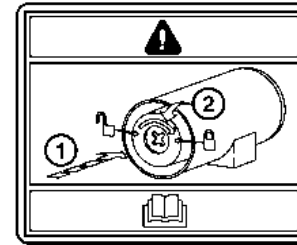

15

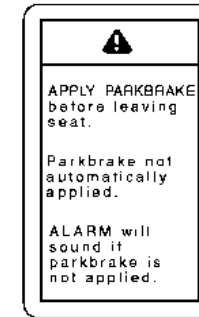

16

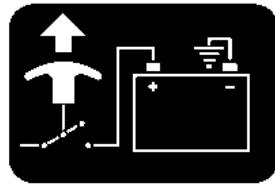

17

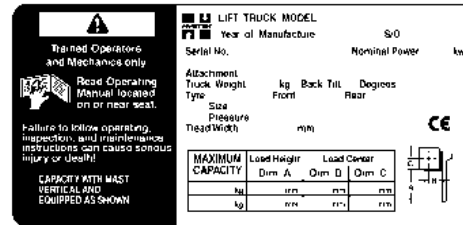

18

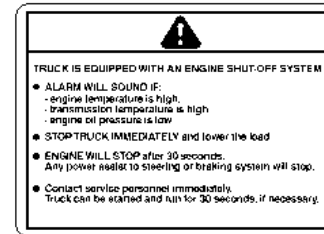

19



20



21



22

HO191251

Figure 3. Warning and Safety Labels (Sheet 5 of 5)



HYSTER

Model Description

Legend for Figure 3

- | | |
|-----------------------------------|---------------------------------------|
| 1. MAST WARNING | 12. ANTIFREEZE WARNING |
| 2. OPERATION WARNING | 13. FLAMMABLE LP GAS WARNING |
| 3. ETHER WARNING (DIESEL) | 14. LPG TANK LABEL |
| 4. DIESEL FUEL LABEL | 15. AIR FILTER CAUTION |
| 5. TIPOVER WARNING | 16. PARK BRAKE WARNING |
| 6. DIESEL EMISSIONS DISPLAY LABEL | 17. EMERGENCY BATTERY DISCONNECT |
| 7. NO RIDERS | 18. NAMEPLATE |
| 8. MAST WARNING | 19. DRIVE TRAIN PROTECTION CAUTION |
| 9. NO ONE ON OR UNDER FORKS | 20. TRANSMISSION LABEL (EXAMPLE ONLY) |
| 10. FAN WARNING | 21. BRAKE FLUID WARNING |
| 11. BORON-FREE LABEL | 22. RADIAL TIRE WARNING |

Display Switch Cluster

WARNING

If any of the instruments, levers, or pedals do not operate as described in the following tables, report the problem immediately. Injury to personnel can occur if the instruments, levers, or pedals do not operate as described in the following tables. **DO NOT** operate the lift truck until the problem is corrected.

NOTE: On the lift truck models covered in this manual, the left side (see **Figure 4**) of the Display Switch Cluster does not perform any functions.

Display Switch Cluster – Right-Side Display Inputs

The lift trucks covered in this manual can have several different options and configurations. Depending on the equipment on the lift truck, warning and indicator lights on the right side of the Display Switch Cluster will vary and the truck may not contain all the warning and indicator lights shown in **Figure 5** and **Table 1**.

Model Description

HYSTER

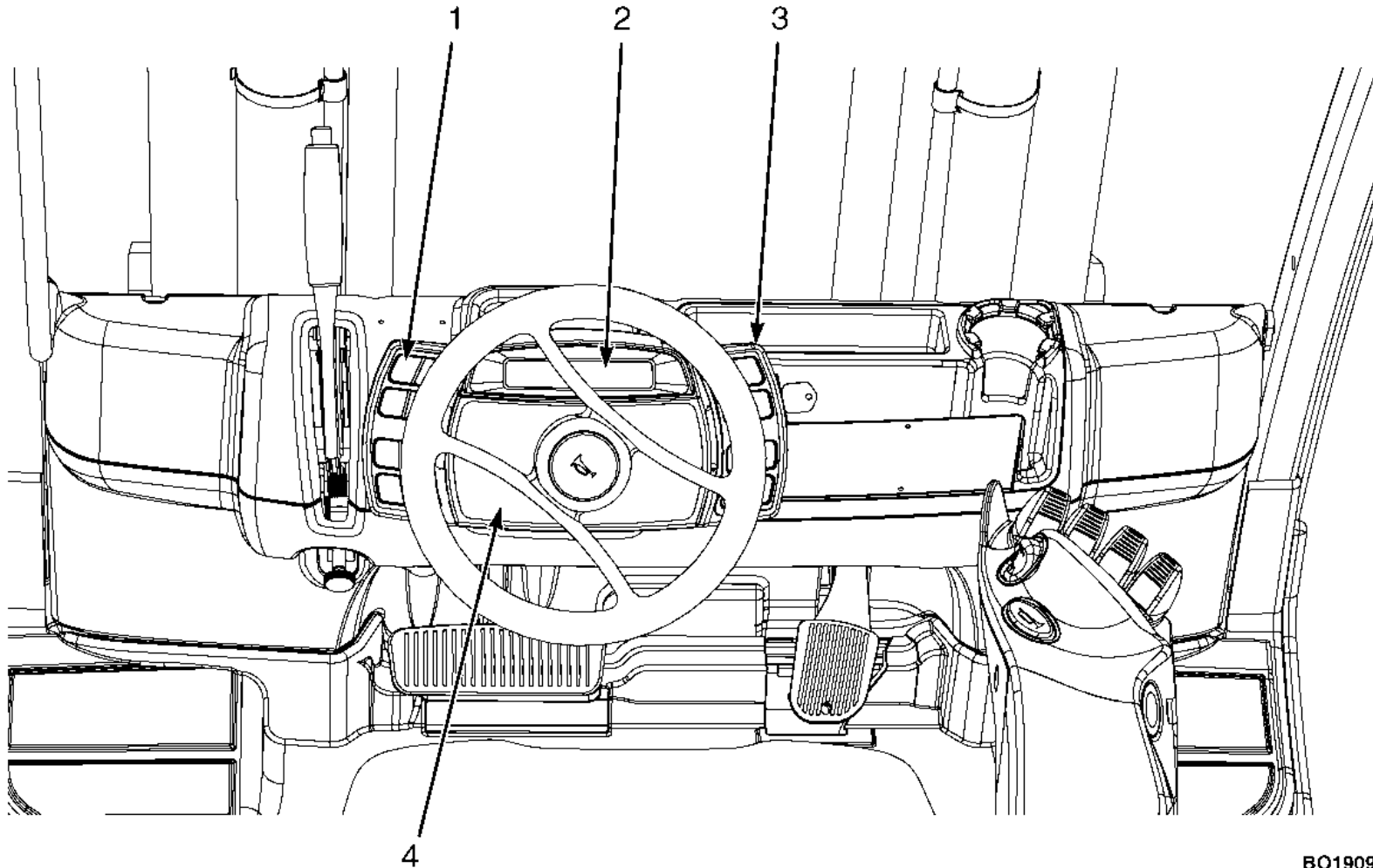

1. LEFT SIDE DISPLAY INPUTS
2. LCD SCREEN
3. RIGHT SIDE DISPLAY INPUTS
4. WARNING AND INDICATOR LIGHTS

BO190930

Figure 4. Display Switch Cluster

HYSTER

Model Description

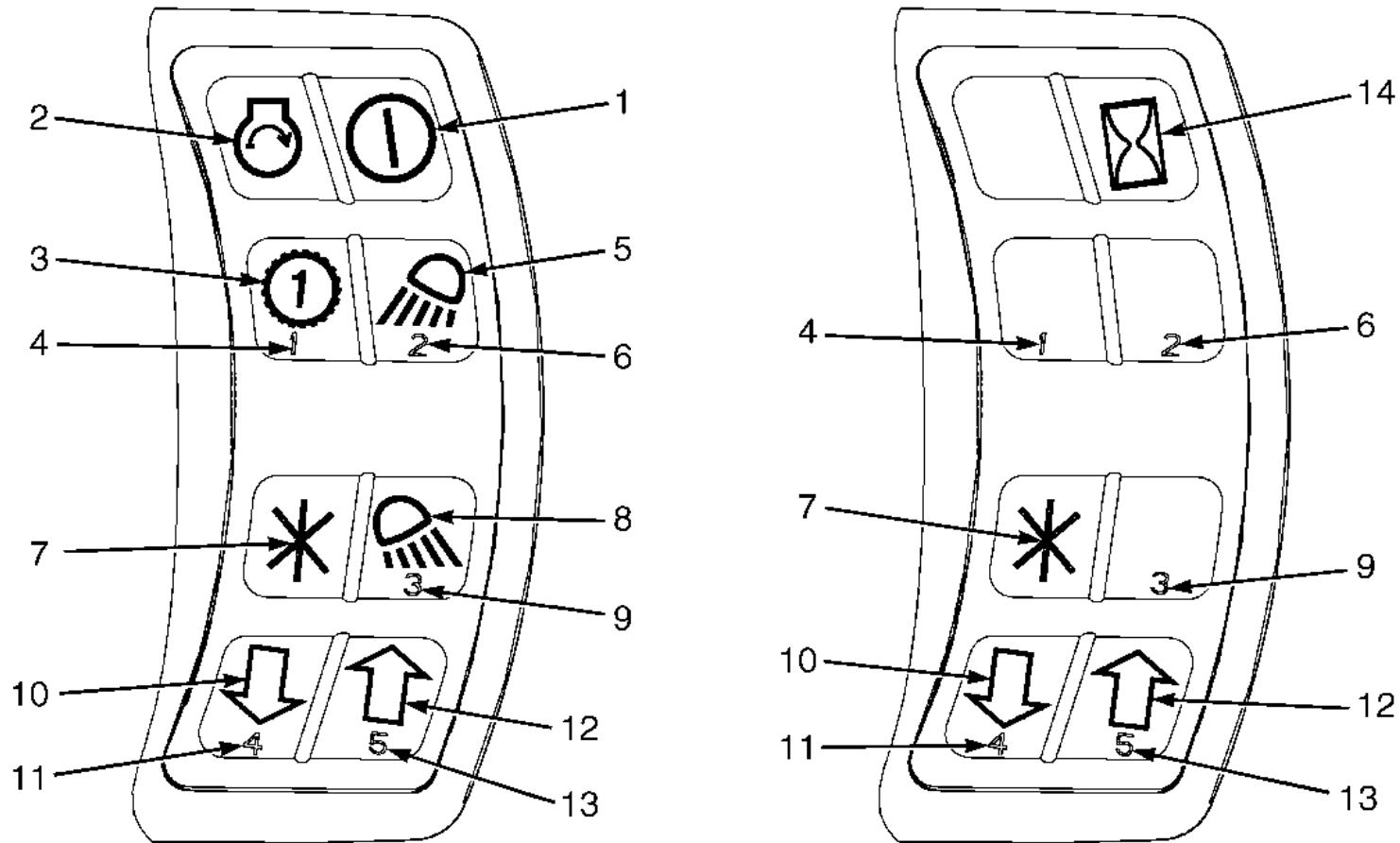

HO190331





Figure 5. Display Switch Cluster - Right Side Display Inputs



Model Description

HYSTER

Table 1. Display Switch Cluster – Right-Side Display Inputs (See Figure 5)



Item No.	Item	Function
1	Power ON/OFF 	<p>If the lift truck is equipped with the keyless start option, lift truck system power is turned ON by pressing this button. To turn the lift truck system power and engine OFF, press the Power ON/OFF button again.</p> <p>If lift truck has a key switch, the Power ON/OFF symbol is replaced with the Hourmeter symbol.</p>
2	Engine Start 	<p>This button is used when the lift truck is equipped with the keyless start option. The engine is started by pressing and holding this button. Lift truck power must be turned ON (pressing Power ON/OFF button) before starting engine.</p> <p>If the lift truck contains a key switch, the Engine Start graphic is covered and the function disabled.</p>
3	1st Gear Locking Button 	This button engages and disengages the 1st Gear Locking function.
4	#1 Button	When an operator or supervisor is in the main menu for entering and administering passwords, the 1st Gear Locking function is disabled and the button is enabled to enter the number 1 for password purposes.
5	Front Work Lights 	This button controls the front work lights and the marker lights on lift trucks equipped with this option.



HYSTER

Model Description

Table 1. Display Switch Cluster – Right-Side Display Inputs (See Figure 5) (Continued)



Item No.	Item	Function
6	#2 Button	<p>If the lift truck is equipped with front work lights, the #2 Button and the Front Work Light button will share space on the Display Switch Cluster.</p> <p>When an operator or supervisor is in the main menu for entering and administering passwords, the Front Work Lights function is disabled and the button is enabled to enter the number 2 for password purposes. If the lift truck is not equipped with Front Work Lights, then this button functions only as Password entry #2.</p>
7	Enter Button (STAR Key) 	<p>This button is used for menu entry, navigation, and data entry.</p>
8	Rear Work Lights 	<p>This button controls the rear work lights on lift trucks equipped with this option.</p>
9	#3 Button	<p>If the lift truck is equipped with rear work lights, the #3 Button and the Rear Work Light button will share space on the Display Switch Cluster.</p> <p>When an operator or supervisor is in the main menu for entering and administering passwords, the Rear Work Lights function is disabled and the button is enabled to enter the number 3 for password purposes. If the lift truck is not equipped with rear work lights, then this button functions only as Password entry #3.</p>



Model Description

HYSTER

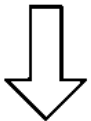
Table 1. Display Switch Cluster – Right-Side Display Inputs (See Figure 5) (Continued)

Item No.	Item	Function
10	Scroll Down 	This button is used for the following functions: <ul style="list-style-type: none"> Decreasing the value of a selected operating function Scrolling downward through a list of possible menu selections
11	#4 Button	The Scroll Down and #4 Button share the same space on the Display Switch Cluster. When an operator or supervisor is in the main menu for entering and administering passwords, the Scroll Down function is disabled and the button is enabled to enter the number 4 for password purposes.
12	Scroll Up 	This button is used for the following functions: <ul style="list-style-type: none"> Increasing the value of a selected operating function Scrolling upward through a list of possible menu selections
13	#5 Button	The Scroll Up and #5 Button share the same space on the Display Switch Cluster. When an operator or supervisor is in the main menu for entering and administering passwords, the Scroll Up function is disabled and the button is enabled to enter the number 5 for password purposes.



HYSTER

Model Description

Table 1. Display Switch Cluster – Right-Side Display Inputs (See Figure 5) (Continued)

Item No.	Item	Function
14	Hourmeter 	<p>NOTE: Lift trucks equipped with key switch start will have the hourmeter symbol in the Display Switch Cluster. Trucks equipped with keyless start option will have the power ON/OFF symbol on the Display Switch Cluster in place of hourmeter symbol. See Figure 5.</p> <p>On trucks with key switch start, when truck is ON, engine hours will be displayed on LCD screen on right side of second line. When truck is OFF, press hourmeter button to display engine hours.</p> <p>On trucks with keyless start option, when truck is ON, engine hours will be displayed on LCD screen on right side of second line. When truck is OFF, engine hours can be displayed when accessing menu to enter password. Password not required to view engine hours.</p> <p>Periodic Maintenance recommendations are based on these hours.</p>



Model Description

HYSTER

Display Switch Cluster – LCD Screen and Warning and Indicator Lights

The LCD screen (see **Figure 6**) shows operator messages for the different functions. The LCD screen can display messages on two lines with up to 20 characters per line. Bar graphs are also shown on the display using solid block characters of varying heights.

The following information is displayed on the LCD screen when the truck is running:

- Engine coolant temperature (standard)
- Fuel level (standard on diesel trucks)

The engine coolant temperature is displayed on the top line and the fuel level is shown on the bottom line. If load weight and travel speed options are available, press the scroll down button to display the information for these fea-

tures. Press the scroll up button to return to the engine coolant temperature and fuel level displays. If a fault occurs, the fault number will be displayed on the top line. The time of day is displayed on the right side of the top line at all times during the selection of displayed text.

The warning lights and indicator symbols shown in **Figure 6** are on all lift truck models. Depending on the equipment on the lift truck, the warning and indicator lights on the Display Switch Cluster will vary and not all the warning and indicator lights shown in **Figure 6** will illuminate. When the warning lights and indicators are on, the operator will see the appropriate symbol. When the warning lights and indicators are off, the operator will see a black panel. Unless noted in **Table 2**, all programmed warning and indicator lights will light up for two seconds (Start Check) when System Power is turned **ON**.

HYSTER

Model Description

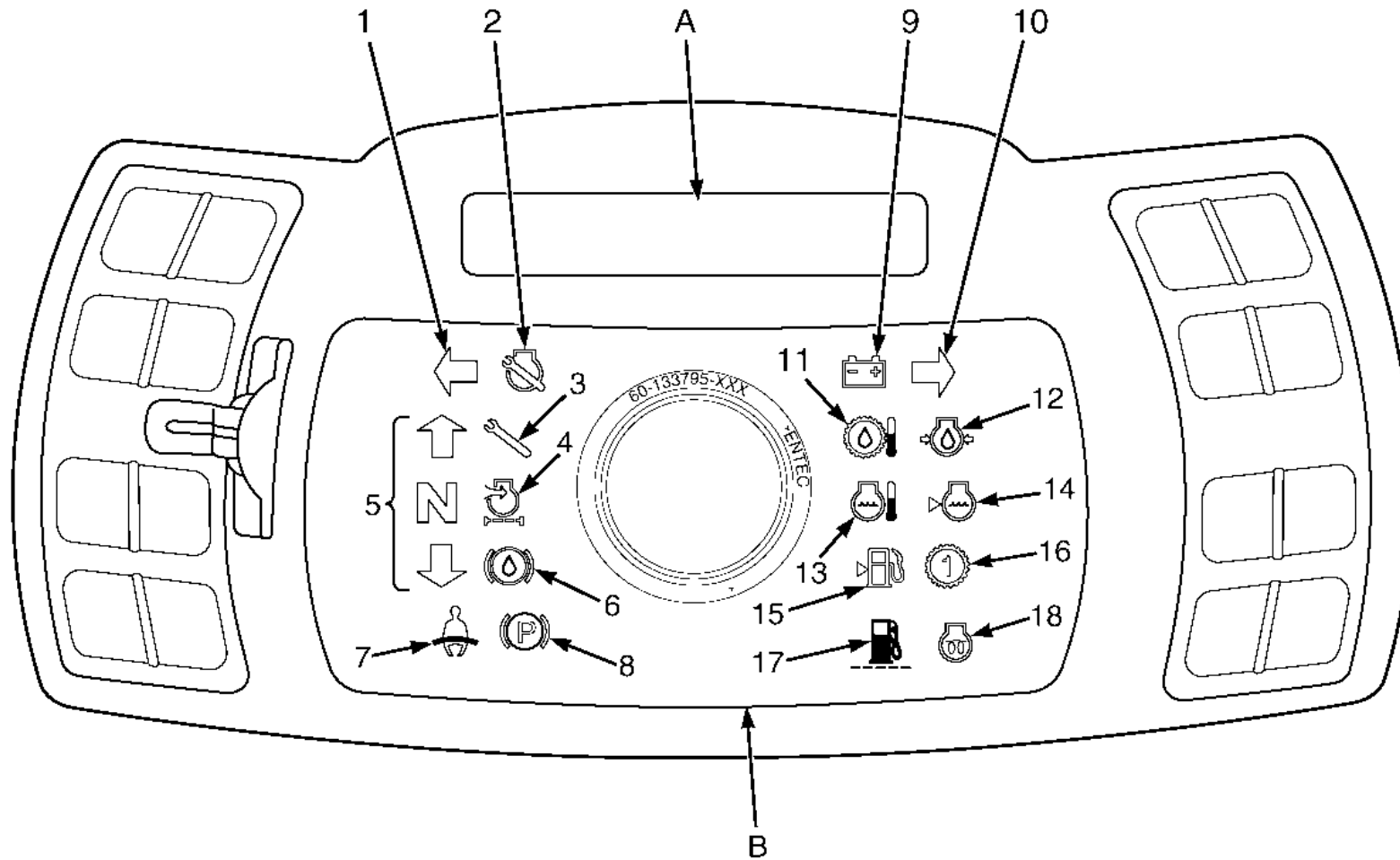

A. LCD SCREEN

B. WARNING AND INDICATOR LIGHTS

Figure 6. Display Switch Cluster - LCD Screen and Warning and Indicator Lights





HO190332



Model Description

HYSTER

Table 2. Display Switch Cluster – Warning and Indicator Lights (See Figure 6)





Item No.	Item	Function
1	Indicator Light Left Turn Signal 	This green indicator will blink on and off when the left turn signal is selected. Not on at Start Check.
2	Warning Light, Engine Mal-function Indicator 	This amber indicator is on when the system is in the ON state, and turns off as the RUN state is entered. This indicator will also illuminate when an engine related fault has occurred. Not on at Start Check.
3	Warning Light, System Mal-function Indicator 	This amber light will illuminate when a fault that is not engine related occurs.
4	Indicator Light Air Filter Restriction 	If the lift truck is equipped with the premium monitoring package, the amber Air Filter Restriction light will illuminate when the air filter restriction switch senses a restriction in the air filter. If there is a restriction in the air filter, visually inspect air filter and remove restriction.



HYSTER

Model Description

Table 2. Display Switch Cluster – Warning and Indicator Lights (See Figure 6) (Continued)



Item No.	Item	Function
5	Indicator Lights Direction and Transmission Lights 	The green direction lights will illuminate when the operator selects the direction of travel. When the transmission is put into NEUTRAL , the green N illuminates and stays lit until transmission is not in NEUTRAL .
6	Warning Light, Brake Fluid Level Malfunction Indica- tor 	 CAUTION DO NOT continue to operate the lift truck if the light is on during operation. The red brake fluid light will illuminate when the brake fluid level switch indicates a low fluid condition.
7	Warning Light, Fasten Seat Belt Malfunction Indi- cator 	 WARNING Always fasten the seat belt when operating the lift truck. Injury to personnel may occur if seat belt is not fastened. The red light is illuminated for 10 seconds after system power is turned ON . Not on at Start Check.



Model Description

HYSTER

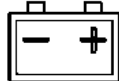
Table 2. Display Switch Cluster – Warning and Indicator Lights (See Figure 6) (Continued)



Item No.	Item	Function
8	Warning Light, Parking Brake Mal- function Indicator 	<p>⚠ WARNING Always apply the parking brake when leaving the lift truck. Failure to apply parking brake may result in injury to personnel.</p> <p>The red parking brake light will illuminate any time the system power is ON and the parking brake lever is moved into the applied position. The indicator light will flash any time the Parking Brake Warning alarm is active. Not on at Start Check.</p>
9	Warning Light, Alternator Malfunc- tion Indicator 	<p>The red Alternator light will illuminate when the system is not in the OFF state and the alternator is not in a charging state. This includes illuminating at System Power On until the normal operating minimum is reached. Not on at Start Check.</p>
10	Indicator Light Right Turn Signal 	<p>This green indicator will blink on and off when the right turn signal is selected. Not on at Start Check.</p>



HYSTER

Model Description

Table 2. Display Switch Cluster – Warning and Indicator Lights (See Figure 6) (Continued)



Item No.	Item	Function
11	Warning Light, Transmission Oil Temperature Malfunction Indi- cator 	 CAUTION Do not continue to operate the lift truck if the red light is ON. Damage to lift truck and transmission may occur. The red light will illuminate when the transmission oil temperature reaches the preset warning level. When light illuminates, and if truck is equipped with optional powertrain protection, truck performance will decrease. Turn truck OFF and notify service person immediately for repair. If truck is not equipped with optional powertrain protection and light is illuminated when engine is running, turn engine OFF immediately and have truck repaired by service technician.



Model Description

HYSTER

Table 2. Display Switch Cluster – Warning and Indicator Lights (See Figure 6) (Continued)



Item No.	Item	Function
12	Warning Light, Engine Oil Pressure Mal- function Indicator 	 <p>CAUTION Stop the engine immediately if the red light is ON while the engine is running. Damage to lift truck and engine may occur.</p> <p>The red light will illuminate when the system is not in the OFF state and the oil pressure sensor indicates an insufficient pressure. This includes illuminating at System Power ON until the normal operating minimum is reached. Not on at Start Check.</p> <p>When light illuminates, lift truck will enter Engine Shutdown mode, if equipped with optional powertrain protection. See Operating Procedures section for Engine Shutdown procedures. If truck is not equipped with optional powertrain protection and light is illuminated when engine is running, turn engine OFF immediately and have truck repaired by service technician.</p>



HYSTER

Model Description

Table 2. Display Switch Cluster – Warning and Indicator Lights (See Figure 6) (Continued)

Item No.	Item	Function
13	Warning Light, Engine Coolant Temperature Malfunction Indi- cator 	 CAUTION Do not continue to operate the lift truck if the light is on during operation. Operation of lift truck with warning light ON may result in damage to engine. If this red light illuminates while the engine is running, it indicates the engine coolant temperature has reached 118 °C (245 °F) or above for 4.3L engines. For Kubota engines, the temperature is 115 °C (240 °F). When light illuminates, lift truck will enter Engine Shutdown mode, if equipped with optional powertrain protection. See Operating Procedures section for Engine Shutdown procedures. If truck is not equipped with optional powertrain protection and light is illuminated when engine is running, turn engine OFF immediately and have truck repaired by service technician.



Model Description

HYSTER

Table 2. Display Switch Cluster – Warning and Indicator Lights (See Figure 6) (Continued)



Item No.	Item	Function
14	Warning Light, Coolant Level in Radiator Malfunction Indicator 	<p>⚠ CAUTION Do not continue to operate the lift truck if the light is on during operation. Operation of lift truck with warning light ON may result in damage to engine.</p> <p>If the lift truck is equipped with the premium monitoring package, this red warning light will illuminate when the radiator coolant level switch indicates that the level of coolant in the radiator is too low.</p> <p>When light illuminates, lift truck will enter Engine Shutdown mode, if equipped with optional powertrain protection. See Operating Procedures section for Engine Shutdown procedures. If truck not equipped with optional powertrain protection and light is illuminated when engine is running, turn engine OFF immediately and check coolant level. If coolant level is satisfactory, have truck repaired by service technician.</p>



HYSTER

Model Description

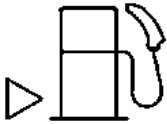
Table 2. Display Switch Cluster – Warning and Indicator Lights (See Figure 6) (Continued)



Item No.	Item	Function
15	Warning Light, Fuel Level Indicator 	 CAUTION Do not allow the lift truck to run out of LPG. Damage to the catalytic converter can result. NOTE: For LPG trucks, see label on dash to identify how your truck is equipped. This red indicator light will illuminate when the fuel level is low. For diesel trucks: The light first illuminates when there is 1/16th of fuel left in the tank. For LPG trucks with LPG pressure switch: The light illuminates when there is 30 seconds to 3 minutes of operation remaining. For LPG trucks with the Premium Low Fuel Sensor: The light illuminates when there is 10 to 20 minutes of operation remaining. An audible alarm will sound every 4 minutes when the red light is illuminated.
16	Indicator Light 1st Gear Locking 	This amber light will illuminate if the operator selects the 1st gear locking feature. The light will flash until the lift truck and engine speed are low enough to permit a shift to 1st gear and stay illuminated while 1st gear lock is active. Not on at Start Check.



Model Description

HYSTER

Table 2. Display Switch Cluster – Warning and Indicator Lights (See Figure 6) (Continued)

Item No.	Item	Function
17	Indicator Light Water Separator (Kubota 3.8L Diesel Only) 	This amber indicator light will illuminate if the fuel-water separator sensor indicates that water must be drained. Not on at Start Check.
18	Indicator Light Cold Start (Diesel Only) 	This amber indicator light will illuminate during the cold start delay period. Not on at Start Check.

Display, Diesel Particulate Filter (DPF)

Lift truck models in this manual may be equipped with the Kubota 3.8L diesel engine. Lift truck equipped with this engine, will also be equipped with an operator's display, for the DPF, mounted to the overhead guard in the upper right corner. See **Figure 7**.

The DPF display will illuminate the appropriate icon(s) according to regeneration level that the lift truck is operating at:

- Passive Regeneration Only (Regeneration Level 0)
- Active Regeneration Inhibited

- Auto/Active Regeneration (Regeneration Level 1)
- Parked Regeneration Request Level (Regeneration Level 2)
- Warning Request Level (Regeneration Level 3)
- Service Request Level (Regeneration Level 4)

HYSTER

Model Description

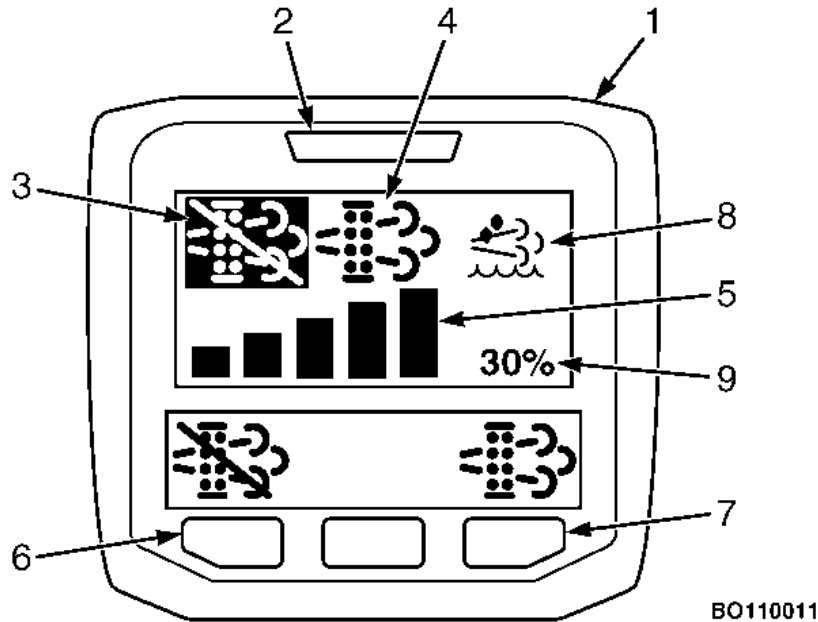

B0110011

1. DPF DISPLAY
2. LED INDICATOR
3. AUTO/ACTIVE REGENERATION INHIBIT ICON
4. PARKED REGENERATION AVAILABLE ICON
5. SOOT LEVEL METER
6. AUTO/ACTIVE REGENERATION INHIBIT ON/OFF BUTTON
7. PARKED REGENERATION INITIATE BUTTON
8. DEF ICON
9. DEF PERCENTAGE

Figure 7. DPF Display

Operator Interface

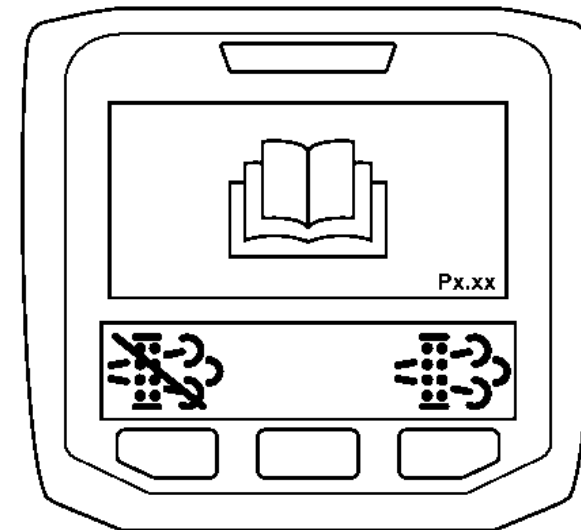

B0210121

Figure 8. Refer to Operator Manual Icon

The Book Icon and DPF software version display at startup for approximately 3 seconds.

The Book Icon will also be shown when operator attempts to initiate a Parked Regeneration when truck is not in the correct state (park brake on, transmission in neutral, etc...). This icon will also be displayed for 30 seconds following an interrupted Parked Regeneration while DPF cools off. See **Figure 8.**

Model Description

HYSTER

CAN Communication Lost

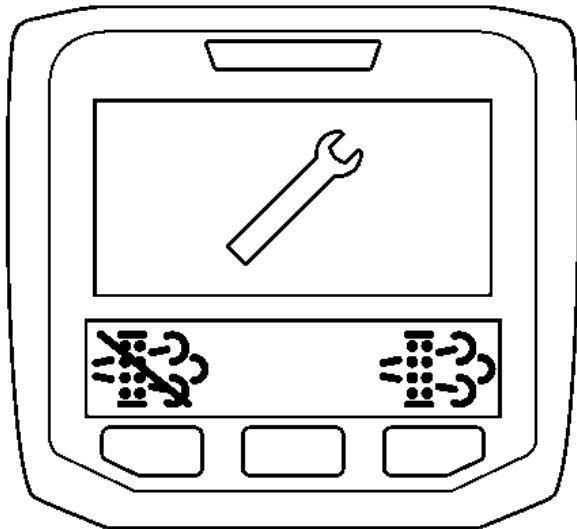

BO210060

Figure 9. CAN Communication Lost Icon

The Wrench Icon is shown when the DPF display loses communication with ECU. See **Figure 9**.

Passive Regeneration Only

Regeneration Level 0

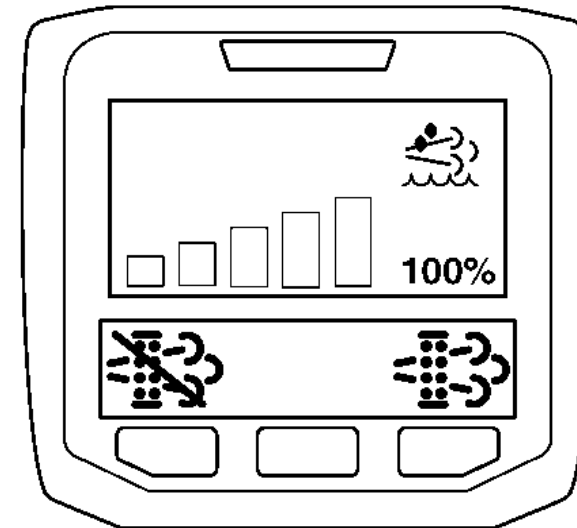

BO110012

Figure 10. Empty Soot Meter

NOTE: Empty Soot Meter will flash if no soot level data is available from ECU. See **Figure 10**.

HYSTER

Model Description

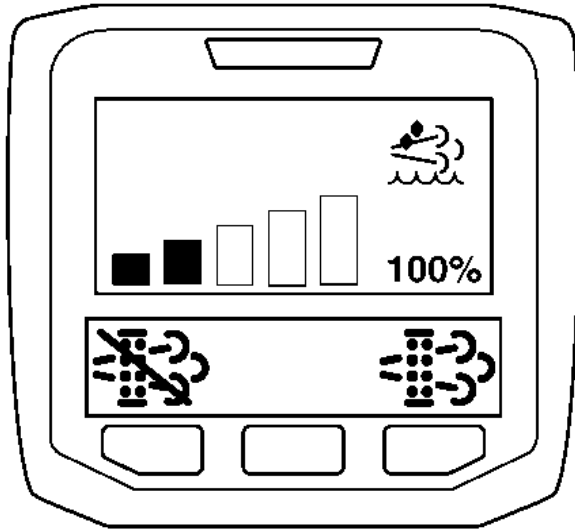

BO110013

Figure 11. Partial Soot Level

Soot Meter bars will fill with increasing soot load in DPF. This is an estimate based on multiple ECU parameters. See **Figure 11**.

Auto/Active Regeneration will begin when the Soot Meter displays 3 bars. If equipped with optional Idle-up feature, engine idle speed will increase during Auto/Active Regeneration.

Auto/Active Regeneration

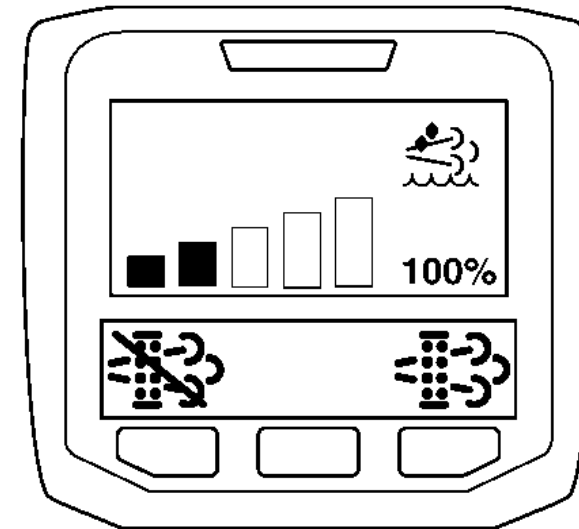

BO110013

Figure 12. Auto/Active Regeneration

NOTE: Auto/Active Regeneration can be inhibited at any time by the operator pressing the Auto/Active Regeneration Inhibit **ON/OFF** button.

Soot meter shows partial soot load. See **Figure 12**.

Auto/Active Regeneration will begin when the Soot Meter displays 3 bars, and remain active at 2, 3, or 4 bars until regeneration is complete. If equipped with optional Idle-up

Model Description

HYSTER

feature, engine idle speed with increase during Auto/Active Regeneration.

Auto/Active Regeneration

Regeneration Level 1

⚠ WARNING

During the Auto/Active Regeneration process, ensure the lift truck operates in a location suitable for elevated exhaust gas temperatures. Make sure the suitable location is free of combustible materials, liquids, and gases. Failure to do so could cause serious injury to operator and/or serious damage to property.

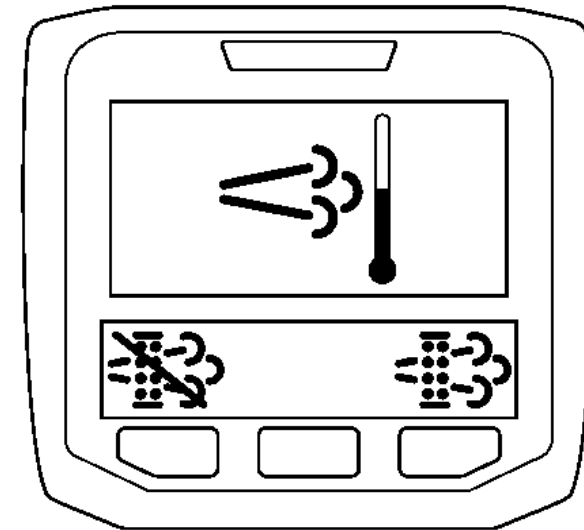

BO210056

Figure 13. High Temperature Icon

Auto/Active Regeneration will begin when engine load and temperature meet appropriate conditions.

During Parked Regeneration, the High Temperature Icon will be displayed. See **Figure 13**.

Lift truck operation can continue without any limitation or loss of power during Auto/Active Regeneration. Higher engine speeds will lead to a more successful Auto/Active Regeneration.

HYSTER

Model Description

Following a successful Auto/Active Regeneration the unit will return to Regeneration Level 0.

Idle-up Auto/Active Regeneration

Lift truck models with Kubota 3.8L diesel engine with DPF may have an optional engine Idle-up feature that is active during Auto/Active Regeneration. Optional Idle-up feature is standard with DuraMatch transmission, not available with Powershift transmission. When the Soot Meter displays 3 bars, engine idle speed will increase the first time the operator applies the accelerator pedal. For the duration of the Auto/Active Regeneration process, minimum engine speed will be 1200 rpm.

This feature improves the Auto/Active Regeneration cleaning process and will take at least 20 minutes to complete. Lift truck operation can continue without any limitations, but avoid engine shut-down while truck is in Idle-up mode.

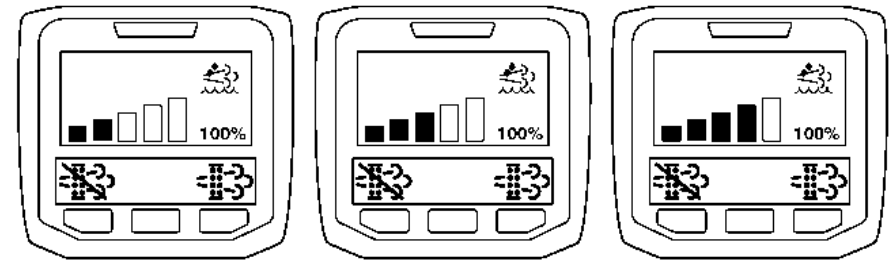

BO110014

Figure 14. Idle-up Active Range

Engine Idle-up will start when the Soot Meter reaches 3 bars and will remain active while 2, 3, or 4 bars are displayed. See **Figure 14**. Optional Parked Regeneration is still possible at 3 or more Soot Meter bars, but should not be required once Auto/Active Regeneration is complete.

Once Auto/Active Regeneration is complete, engine idle speed returns to normal.

Model Description

HYSTER

Parked Regeneration Request

Regeneration Level 2

After unsuccessful Auto/Active Regeneration, the ECU will request a Parked Regeneration. DPF icon and LED are on to indicate Parked Regeneration is available. See **Figure 15**.

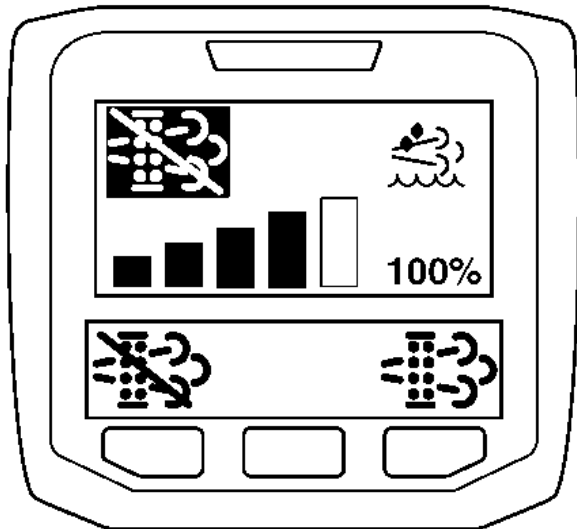

BO110015

Figure 15. Parked Regeneration Request

WARNING

Prior to initiating the Parked Regeneration process, move the lift truck to a location suitable for elevated exhaust gas temperatures. Make sure the suitable location is free of combustible materials, liquids, and gases. Failure to do so could cause serious injury to operator and/or serious damage to property.

To initiate the Parked Regeneration process, the operator needs to push the Parked Regeneration Initiate Button after all of the following conditions have been met. See **Figure 15**.

- Engine running
- Park Brake **ON**
- Transmission in Neutral
- Accelerator pedal **NOT** depressed
- Soot Meter displays 3, 4, or 5 bars

When Parked Regeneration is in process the High Temperature Icon will be displayed. See **Figure 13**.

HYSTER

Model Description

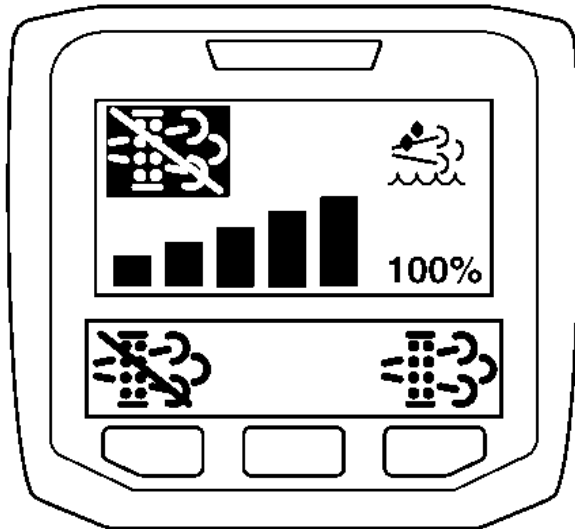

BO110016

Figure 16. DPF Display - 5 Bar Soot Meter

Following a successful Parked Regeneration the unit will return to Regeneration Level 0.

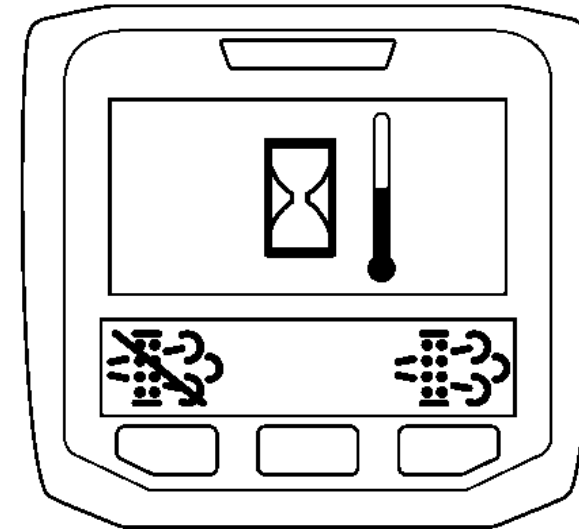

BO210058

Figure 17. Engine Warming Up Icon

If Parked Regeneration process is initiated before lift truck has warmed up properly, the Engine Warming Up Icon will be displayed. See **Figure 17**.



Model Description

HYSTER

Warning Level

Regeneration Level 3

NOTE: Level 3 is the last opportunity for operator to initiate the DPF regeneration process before a service technician will be required.

Regeneration Level 3 begins when Soot Meter displays 5 bars. See **Figure 16**

DPF Icon is on and LED is flashing to indicate Parked Regeneration is necessary. See **Figure 15**.

Auto/Active Regeneration is no longer enabled by ECU. DPF regeneration must be performed through Parked Regeneration process.

At this regeneration level there is a 50% torque derate and 1600 RPM limit on the engine.

MIL on dash is on and diagnostic trouble code (DTC) will be displayed. Successful Parked Regeneration will clear active code and return unit to Regeneration Level 0.

Service Level

Regeneration Level 4

CAUTION

Regeneration Level 4 is the last opportunity for service technician to initiate Parked Regeneration process. Continued operation of lift truck without performing a Parked Regeneration will result in permanent damage to the Diesel Particulate Filter (DPF), resulting in costly repairs.

DPF Icon and LED both flash to indicate Parked Regeneration must be completed by using PC Service Tool. See **Figure 15**.

At this regeneration level there is a 50% torque derate and 1200 RPM limit on the engine.

MIL on dash is on and diagnostic trouble code (DTC) will be displayed. Successful Parked Regeneration will clear active code and return unit to Regeneration Level 0.

HYSTER

Model Description

Diesel Exhaust Fluid (DEF)

NOTE: The status of the DEF tank is indicated on the DPF Display. DPF functionality is unchanged.

Normal DEF

1. At >10% the following is applicable, see **Figure 18**:

- a. DEF quality is Good.
- b. DEF level >10%.
- c. DEF Icon is **ON**.
- d. DEF Level % is **ON**.
- e. DPF Regen is available.
- f. No DTC is shown.

g. Derate is none.

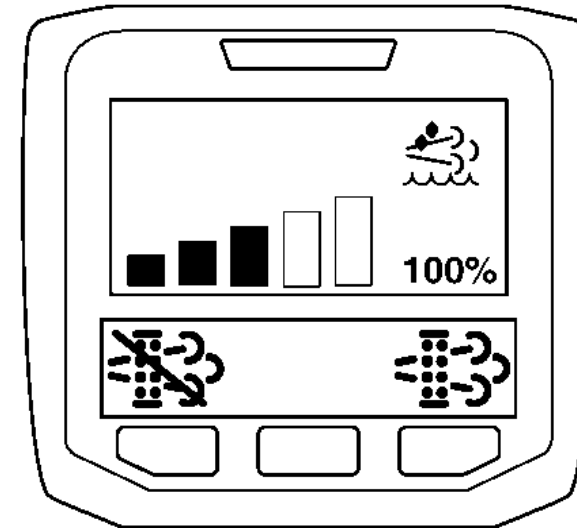

BO210141

Figure 18. DEF Normal

Model Description

HYSTER

Low DEF

1. At <10% the following is applicable, see **Figure 19**:
 - a. DEF quality is Good.
 - b. DEF level <10%.
 - c. DEF Icon is **FLASHING**.
 - d. DEF Level % is **ON**.
 - e. DPF Regen is available.
 - f. No DTC is shown.
 - g. Derate is none.

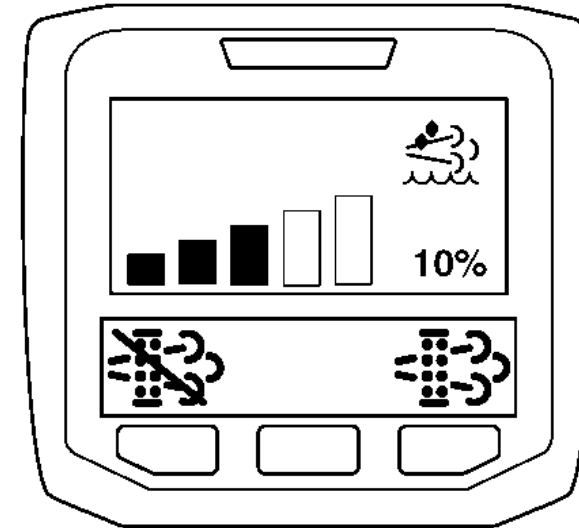

BO210142

Figure 19. DEF Low

HYSTER

Model Description

Empty DEF

1. At 0% the following is applicable, see **Figure 20**:
 - a. DEF quality is Good.
 - b. DEF level 0%.
 - c. DEF Icon is **FLASHING**.
 - d. DEF Level % is **FLASHING**.
 - e. DPF Regen is unavailable.
 - f. DTC on dash shown.
 - g. Engine speed and torque derate.

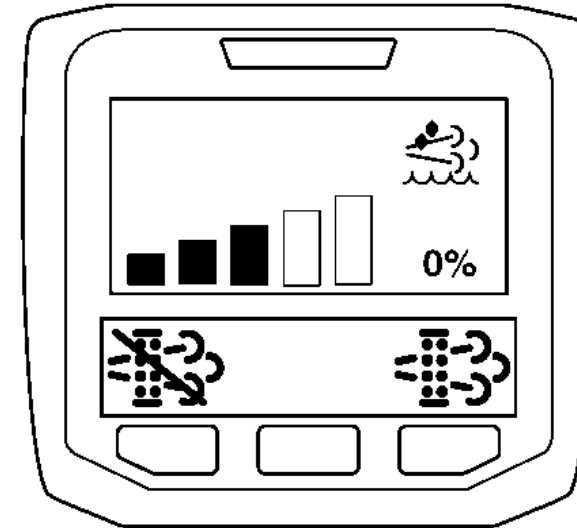

BO210143

Figure 20. DEF Empty

2. Fill DEF tank with at least 4 liter (1 gal) to reset DTC and resume normal operation. See **Refilling DEF Tank** for fill procedures.

Model Description

HYSTER

Bad DEF Quality

1. If DEF quality is bad the following is applicable, see **Figure 21**:

- a. DEF quality is Bad.
- b. DEF level Any Level.
- c. DEF Icon is **ON with Slash**.
- d. DEF Level % is **ON**.
- e. DPF Regen is unavailable.
- f. DTC for auto clear shown.
- g. Derate is Level 2.

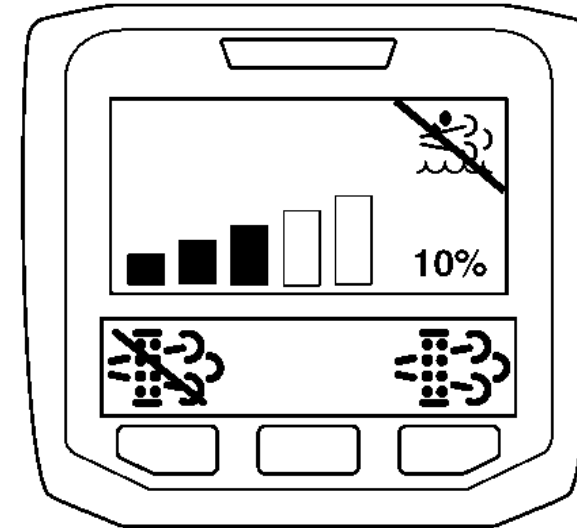

BO210144

Figure 21. DEF Quality ICON

Operator Controls

(See Table 3 and Figure 22)

WARNING

If any of the controls, instruments, levers, or pedals do not operate as described in the following tables, report the problem immediately. Injury to personnel can occur if the instruments, levers, or pedals do not operate as described in the following tables. **DO NOT** operate the vehicle until the problem is corrected.

HYSTER

Model Description

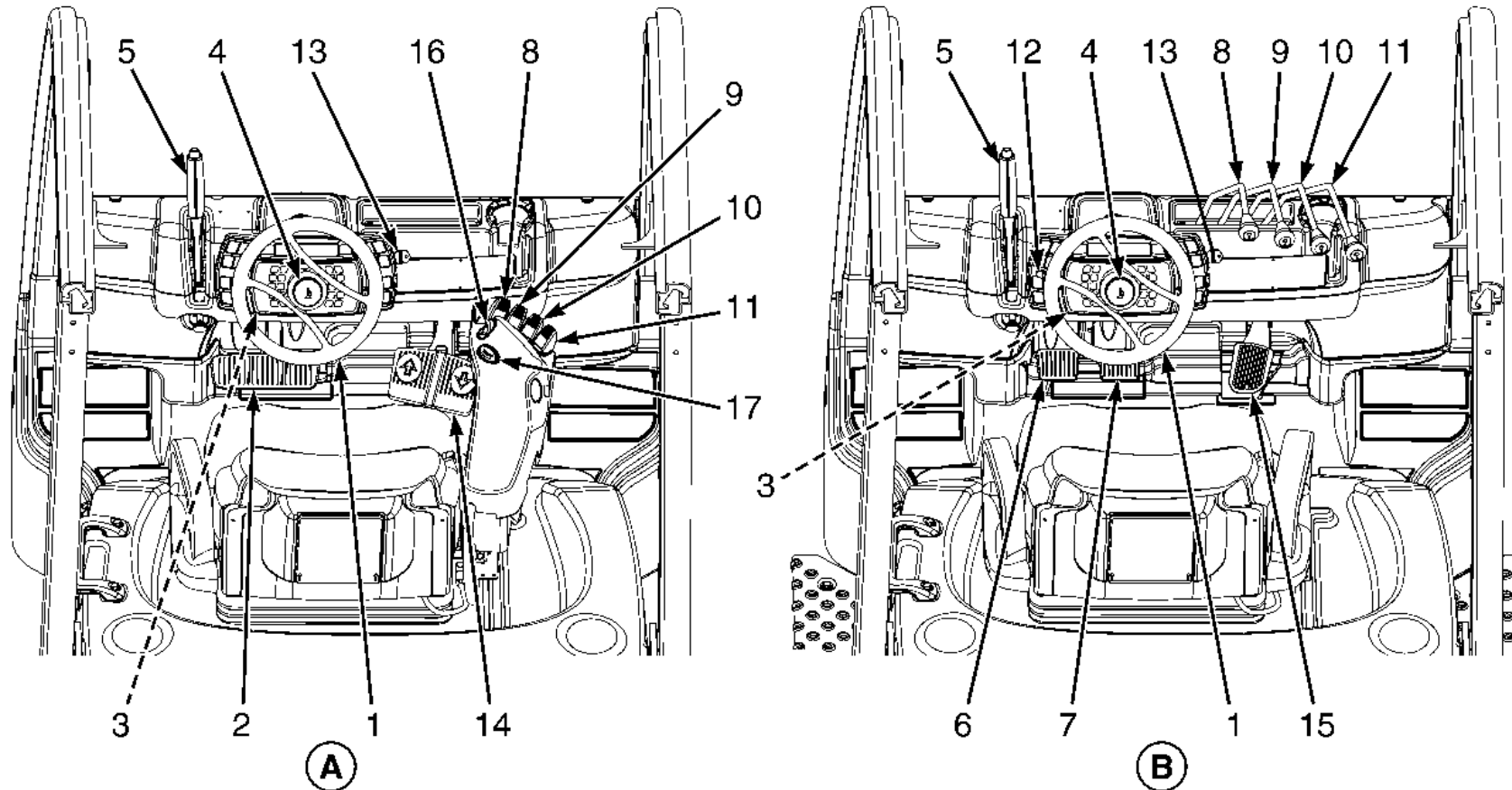

HO191077

- A. UNITS WITH MONOTROL® PEDAL AND E-HYDRAULICS
- B. UNITS WITH DIRECTIONAL CONTROL LEVER AND MANUAL HYDRAULICS

Figure 22. Operator Controls



Model Description

HYSTER

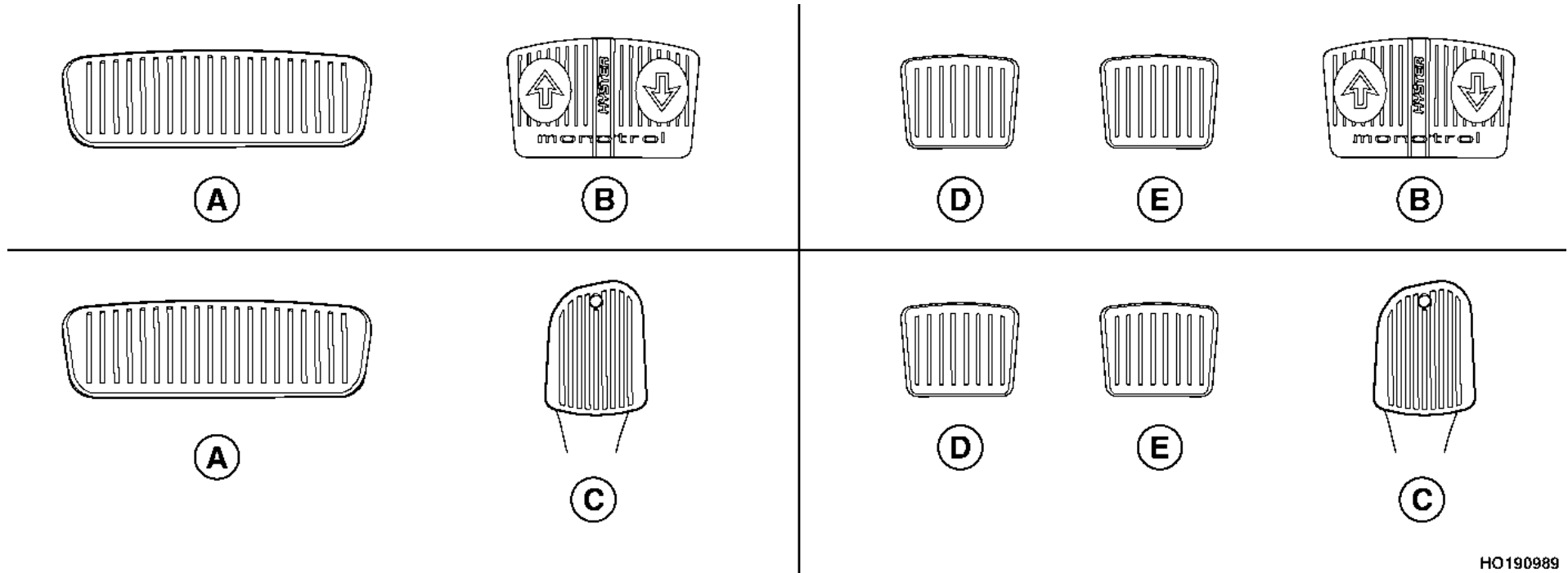

- A. INCHING/BRAKE PEDAL
- B. MONOTROL® PEDAL
- C. ACCELERATOR PEDAL

- D. INCHING/BRAKE PEDAL
- E. BRAKE PEDAL

HO190989

Figure 23. Operator Compartment Pedal Configurations



HYSTER

Model Description

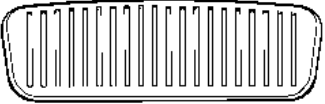
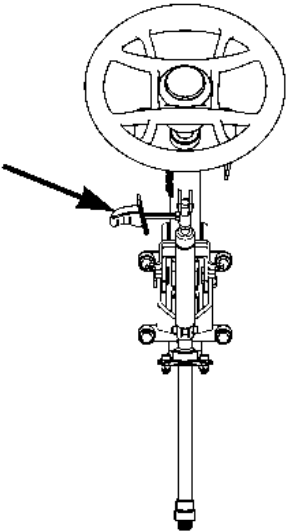

Table 3. Operator Controls (See Figure 22)

Item No.	Item	Function
1	Steering Wheel	The steering wheel controls the position of the steer tires.
2	Inching/Brake Pedal  BO190617	By varying the position of the inching/brake pedal, the operator can move the lift truck slowly while a high engine speed is used for lifting loads. Completely depressing the pedal disengages the transmission and applies the service brakes. The brake lights will be on when the brake pedal is depressed during normal operation. On units with a MONOTROL® pedal, the engine can be started when the inching/brake pedal is fully depressed or when the parking brake is applied.

Model Description

HYSTER

Table 3. Operator Controls (See Figure 22) (Continued)

Item No.	Item	Function
3	Lever For Steering Column Tilt 	To move the steering column up, pull up on the tilt lever and the steering column moves up. Release the lever when the steering column reaches the desired position. To move the steering column down, grab the steering wheel and pull up on the lever. Pull the steering column to the desired position.
4	Horn 	The horn button controls the operation of the horn.

HYSTER

Model Description

Table 3. Operator Controls (See Figure 22) (Continued)

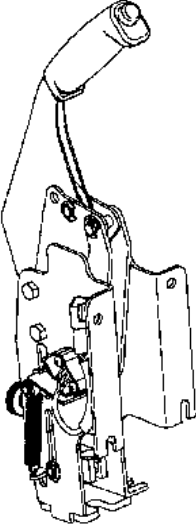
Item No.	Item	Function
5	Parking Brake Lever 	<p>⚠ WARNING Correct adjustment is necessary to provide adequate braking. Injury to personnel can occur if parking brake is not adjusted correctly. See the Maintenance section for adjustment procedures.</p> <p>Always apply the parking brake when leaving the lift truck.</p> <p>⚠ CAUTION Damage to lift truck and equipment can occur if parking brake is not applied when operator leaves lift truck.</p> <p>NOTE: There is a sensor in the seat that actuates an audible alarm. If the operator leaves the seat, with system power OFF, without applying the parking brake, the alarm will sound for 10 seconds until the parking brake is applied or the operator sits back on the seat. If system power is ON or the engine is running, and the operator leaves the seat, without applying the parking brake, the alarm will sound continuously until parking brake is applied or the operator sits back on the seat.</p>



Model Description

HYSTER

Table 3. Operator Controls (See Figure 22) (Continued)

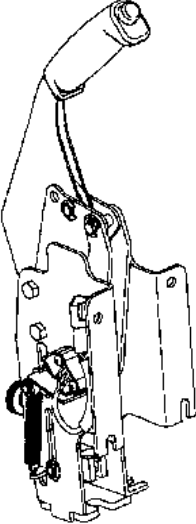
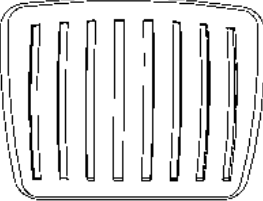
Item No.	Item	Function
5 (cont)	<p>Parking Brake Lever</p> 	<p>The lift truck is equipped with a lever to apply the parking brake. Pull the lever to apply the parking brake. Use your thumb to release the button on the lever when the lever is moved to release the parking brake.</p> <p>On units with a MONOTROL® pedal, applying the parking brake puts the transmission in NEUTRAL. The parking brake must be fully applied when operator leaves the lift truck. The lift truck can be started with the park brake applied.</p>
6	<p>Inching/Brake Pedal</p>  <p>BO190632</p>	<p>By varying the position of the inching/brake pedal, the operator can move the lift truck slowly while a high engine speed is used for lifting loads. Completely depressing the pedal disengages the transmission and applies the service brakes. The engine can be started when the inching/brake pedal is fully depressed and Direction Control Lever is in neutral.</p>



HYSTER

Model Description

Table 3. Operator Controls (See Figure 22) (Continued)

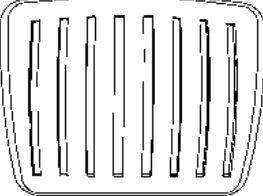
Item No.	Item	Function
7	Brake Pedal  BO190632	This pedal, controlled by the operator's right foot, controls the application of the service brakes.



Model Description

HYSTER

Table 3. Operator Controls (See Figure 22) (Continued)

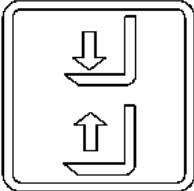
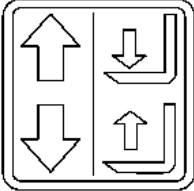
Item No.	Item	Function
8	<p>Lift/Lower Control Lever</p>  <p>LIFT</p>  <p>FR LIFT BO190623</p>	<p>⚠ CAUTION If the lift truck is equipped with a 3-stage mast, in circumstances where overhead clearance is restricted, be sure inner mast/carriage does not extend before full free lift of the mast is reached.</p> <p>NOTE: Cold hydraulic oil and high oil flow rates may cause the inner mast to extend above the outer mast before full free lift is reached. The hydraulic oil must be hot if the lift truck is to be operated where overhead clearance is restricted.</p> <p>To assure hydraulic oil is hot, operate mast at full lift speed and observe for movement of the inner mast before full free lift is reached. If any inner mast movement occurs, fully lower carriage, place the transmission into neutral, set the park brake, and then hold the tilt mini-lever fully open at engine governed speed for approximately 3 minutes.</p> <p>Repeat above procedure until no movement of the inner mast is observed, then proceed with lift truck operation.</p>



HYSTER

Model Description

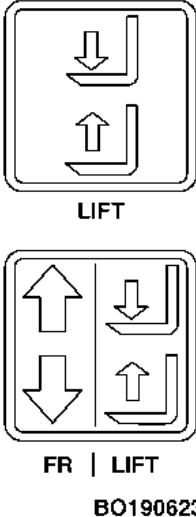

Table 3. Operator Controls (See Figure 22) (Continued)

Item No.	Item	Function
8 (cont)	<p>Lift/Lower Control Lever</p>  <p>LIFT</p> <p>FR LIFT</p> <p>BO190623</p>	<p>NOTE: Manual hydraulic control levers are standard on the trucks covered in this manual (see Figure 22). Electronic hydraulic mini-levers (see Figure 22) are available as an optional control feature for the hydraulic functions.</p> <p>NOTE: To operate the mini-levers, the operator must be on the seat.</p> <p>The lift/lower control lever can be either the first manual lever or first mini-lever to the right of the operator's seat. Pull the lever backward toward the operator to raise the carriage and forks. Push the lever forward to lower the carriage and forks.</p>

Model Description

HYSTER

Table 3. Operator Controls (See Figure 22) (Continued)



Item No.	Item	Function
9	<p>Tilt Control Lever</p>  <p>TILT</p>  <p>RTST BO190624</p>	<p>NOTE: Manual hydraulic control levers are standard on the trucks covered in this manual (see Figure 22). Electronic hydraulic mini-levers (see Figure 22) are available as an optional control feature for the hydraulic functions.</p> <p>NOTE: To operate the mini-levers, the operator must be on the seat.</p> <p>The tilt control lever can be either the second manual lever or second mini-lever to the right of the operator's seat. Push the lever forward to tilt the mast and forks forward. Pull the lever backward toward the operator to tilt the mast and forks backward.</p> <p>These trucks can be equipped with the Return to Set Tilt (RTST) option if truck has electronic hydraulic mini-levers. The RTST option automatically stops the tilt function at a set point. To override the RTST option, momentarily push and release the override button located directly behind the tilt mini-lever and push the tilt mini-lever forward or pull backward.</p>



HYSTER

Model Description

Table 3. Operator Controls (See Figure 22) (Continued)

Item No.	Item	Function
9 (cont)	<p>Tilt Control Lever</p> <div style="text-align: center;">  <p>TILT</p>  <p>RTST</p> <p>BO190624</p> </div>	<p>When tilt set point delay feature is used in setup hydraulics, a timer can be set so the override button is not used. The operator keeps the tilt mini-lever actuated for the programmed amount of time (0.1 to 3.0 seconds). The RTST will be overridden, and tilt will continue.</p> <p>RTST is intended as an operator aid in positioning forks or attachments for their application to minimize product damage and facilitate load handling. Care should be taken to operate the truck in accordance with load handling instructions as described in Operating Techniques in the Operating Procedures section of this Operating Manual.</p>



Model Description

HYSTER

Table 3. Operator Controls (See Figure 22) (Continued)

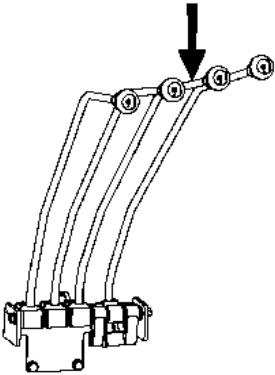
Item No.	Item	Function
10	<p>Manual Control Lever for Auxiliary Hydraulic Functions (3rd lever). See Figure 22.</p> 	<p>NOTE: A manual control lever with a detent must be installed when an attachment with a clamp is installed. See your dealer for Hyster lift trucks to get the correct control lever.</p> <p>NOTE: Manual hydraulic control levers are standard on the trucks covered in this manual (see Figure 22). Electronic hydraulic mini-levers (see Figure 22) are available as an optional control feature for the hydraulic functions.</p> <p>NOTE: If truck is equipped with only three levers and clamp attachment, the last (3rd) lever controls clamp functions.</p> <p>The third manual control lever is installed to the right of the manual tilt control lever. This lever can have two methods of operation, depending on the attachment.</p> <p>Control Lever with a Detent - Attachments with a clamp action: The lever is spring-loaded toward the operator. The lever is operated by moving it to the right, then forward and back.</p> <p>Control Lever without a Detent - Attachments without a clamp action: The lever is operated by moving it forward and back.</p>



HYSTER

Model Description

Table 3. Operator Controls (See Figure 22) (Continued)

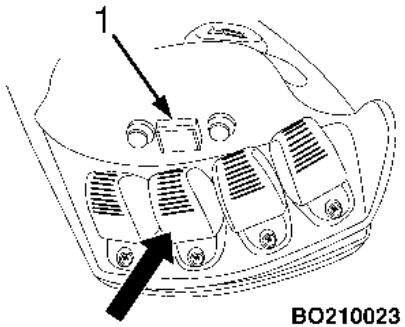
Item No.	Item	Function
10	<p>Electronic Control Mini-Lever for Auxiliary Hydraulic Functions (3rd lever). See Figure 22.</p>  <p>BO210023</p> <p>1. OVERRIDE BUTTON</p>	<p>NOTE: The lift trucks covered in this Operating Manual may be equipped with optional electronic hydraulic mini-levers that are available for the hydraulic functions.</p> <p>NOTE: To operate the mini-levers, the operator must be on the seat.</p> <p>NOTE: If truck is equipped with only three levers and clamp attachment, the last (3rd) lever controls clamp functions.</p> <p>The third electronic control mini-lever is installed to the right of the electronic tilt control lever. This lever can have two methods of operation, depending on the attachment.</p> <p>Trucks with Clamp Attachment: To engage the clamp, move the mini-lever backward. To disengage the clamp, momentarily push and release the override button located directly behind the mini-lever and push the mini-lever forward.</p> <p>Trucks without Clamp Attachment: The lever is operated by moving it forward and back. The lever is spring-loaded to return to the neutral position when released.</p>



Model Description

HYSTER

Table 3. Operator Controls (See Figure 22) (Continued)

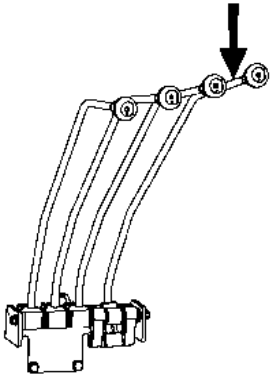
Item No.	Item	Function
11	<p>Manual Control Lever for Auxiliary Hydraulic Functions (4th lever). See Figure 22.</p> 	<p>NOTE: A manual control lever with a detent must be installed when an attachment with a clamp is installed. See your dealer for Hyster lift trucks to get the correct control lever.</p> <p>NOTE: Manual hydraulic control levers are standard on the trucks covered in this manual (see Figure 22). Electronic hydraulic mini-levers (see Figure 22) are available as an optional control feature for the hydraulic functions.</p> <p>NOTE: If truck is equipped with four levers and clamp attachment, the last (4th) lever controls clamp functions.</p> <p>The fourth manual control lever is installed to the right of the third manual control lever. This lever can have two methods of operation, depending on the attachment.</p> <p>Control Lever with a Detent - Attachments with a clamp action: The lever is spring-loaded toward the operator. The lever is operated by moving it to the right, then forward and back.</p> <p>Control Lever without a Detent - Attachments without a clamp action: The lever is operated by moving it forward and back.</p>



HYSTER

Model Description

Table 3. Operator Controls (See Figure 22) (Continued)

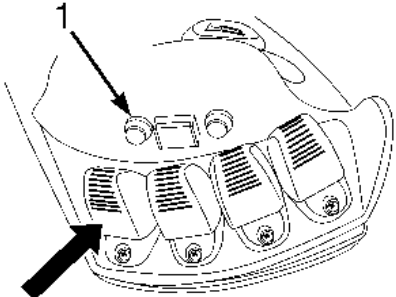
Item No.	Item	Function
11	<p>Electronic Control Mini-Lever for Auxiliary Hydraulic Functions (4th lever). See Figure 22.</p>  <p style="text-align: center;">B0210024</p> <p>1. OVERRIDE BUTTON</p>	<p>NOTE: The lift trucks covered in this Operating Manual may be equipped with optional electronic hydraulic mini-levers that are available for the hydraulic functions.</p> <p>NOTE: To operate the mini-levers, the operator must be on the seat.</p> <p>NOTE: If truck is equipped with four levers and clamp attachment, the last (4th) lever controls clamp functions.</p> <p>The fourth electronic control lever is installed to the right of the third electronic control lever. This lever can have two methods of operation, depending on the attachment.</p> <p>Trucks with Clamp Attachment: To engage the clamp, move the mini-lever backward. To disengage the clamp, momentarily push and release the override button located directly behind the mini-lever and push the mini-lever forward.</p> <p>Trucks without Clamp Attachment: The lever is operated by moving it forward and back. The lever is spring-loaded to return to the neutral position when released.</p>



Model Description

HYSTER

Table 3. Operator Controls (See Figure 22) (Continued)

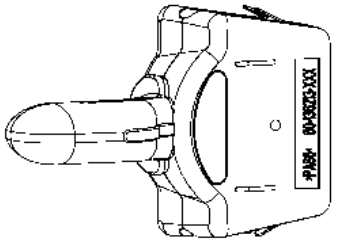

Item No.	Item	Function
12	Direction Control Lever  <p style="text-align: right; margin-right: 50px;">BO210067</p>	<p>NOTE: There is a sensor in the seat that actuates an audible buzzer. If the operator leaves the seat with the key switch ON and the lever is not in NEUTRAL, the buzzer will pulse ON and OFF for 10 seconds.</p> <p>The Direction Control Lever for the transmission is on the left side of the Display Switch Cluster. The Direction Control Lever is used on lift trucks without a MONOTROL® pedal. The Direction Control Lever has three positions that are indicated by three green lights on left side of Display Switch Cluster (see Figure 6 and Table 2): FORWARD, NEUTRAL (N), and REVERSE. Move the lever to one of the direction positions for travel. The Direction Control Lever must be in the NEUTRAL (N) position before the engine can be started. The reverse lights will be on and, if equipped, reverse alarm will be activated when the lever is placed in the REVERSE position.</p> <p>If lift truck is equipped with a MONOTROL® pedal, the lever on the left side of the Display Switch Cluster functions as the turn signal lever. Push the lever up to signal a right turn. Pull the lever down to signal a left turn.</p>



HYSTER

Model Description

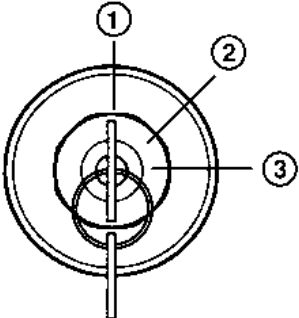
Table 3. Operator Controls (See Figure 22) (Continued)

Item No.	Item	Function
13	<p>Key Switch</p>  <p>BO190097</p>	<p>NOTE: There is no mechanical lockout that prevents the key switch from being returned to the START position without first being returned to the OFF position. However, the Vehicle System Manager (VSM) software prevents the starter motor from being energized while the engine is running.</p> <p>The key switch is located on the right side of the Display Switch Cluster. The key switch has three positions:</p> <p>No. 1 Position: OFF position. De-energizes all electric circuits except for the horn and front and rear work lights.</p> <p>No. 2 Position: ON position. Energizes all electric circuits except the starter circuit. The key switch will be in this position during normal operation.</p> <p>No. 3 Position: START position. Energizes the starter motor for starting the engine. A spring returns the key to position No. 2 (ON position) when the key is released.</p>
14	<p>MONOTROL® Pedal</p>  <p>BO210020</p>	<p>The MONOTROL® pedal controls the speed and direction of the lift truck. Pushing on the right side of the pedal causes the lift truck to move in reverse. Pushing on the left side of the pedal causes the lift truck to move in forward. The speed of the engine increases as the pedal is depressed. The reverse lights and the optional reverse alarm will be on in the reverse position during normal operation.</p>

Model Description

HYSTER

Table 3. Operator Controls (See Figure 22) (Continued)

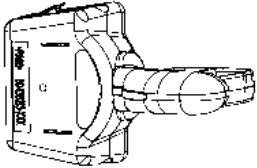
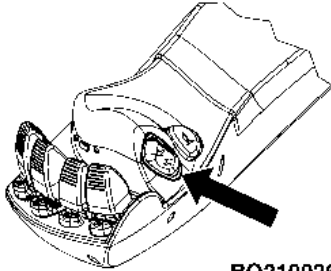
Item No.	Item	Function
15	Accelerator Pedal  BO190098	This pedal controls the speed of the engine and is operated by the operator's right foot. It is used on units that have a Direction Control Lever.
16	Turn Signal Lever  BO190335	If lift truck is not equipped with a MONOTROL® pedal, the turn signal lever is on the right side of the Display Switch Cluster. Push the lever up to signal a left turn. Pull the lever down to signal a right turn.
17	Direction Control Switch  BO210026	The direction control switch for the transmission is next to the auxiliary horn button on the armrest. The direction control switch is used on lift trucks without a MONOTROL® pedal.



HYSTER

Model Description

Table 3. Operator Controls (See Figure 22) (Continued)

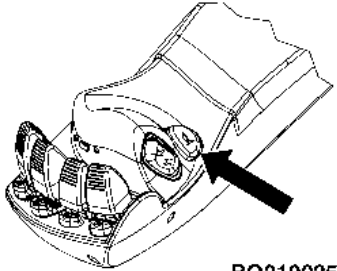
Item No.	Item	Function
18	Auxiliary Horn Button 	Auxiliary horn button functions when the key or keyless ignition is in the ON position and up to 20 minutes after the key or keyless ignition is turned to the OFF position.







Model Description

HYSTER

Auxiliary Control Levers

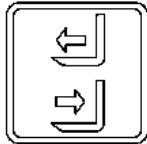
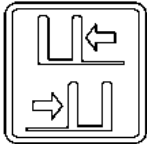
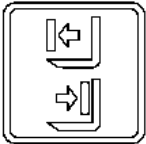
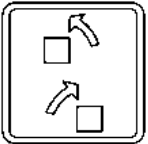
Table 4. Auxiliary Control Levers

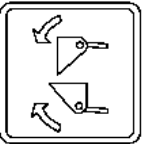
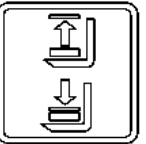
Function	Direction of Movement	
	Load or Equipment	Control Lever
1. REACH	Retract/Extend	Backward/Forward
2. SIDESHIFT	Right/Left	Backward/Forward
3. PUSH-PULL	Backward/Forward	Backward/Forward
4. ROTATE	Clockwise/Counterclockwise	Backward/Forward
5. UPENDER	Up/Down	Backward/Forward
6. SCOOP	Up/Down	Backward/Forward
7. LOAD STABILIZER	Down (Clamp)/Up (Release)	Backward/Forward
8. SWING (FORKS)	Right/Left	Backward/Forward
9. FORK SPREAD	Together/Apart	Backward/Forward
10. CLAMP	Clamp/Release	Backward/Forward

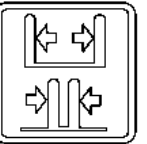
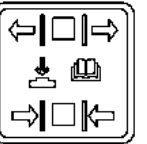
1	2	3	4	5	6	7	8	9	10
									

BO190744



HYSTER

Operating Procedures

Operating Procedures

General

Know Your Lift Truck

WARNING

Always make sure the parking brake is fully applied before leaving the lift truck. If the operator leaves the lift truck without applying the parking brake, a seat activated switch will shift the transmission to neutral, and sound an alarm for 10 seconds. If the lift truck is left on a grade, without the parking brake fully applied, the lift truck will freewheel down the grade, possibly causing injury or property damage.

WARNING **EXHAUST GASES**

Exhaust from internal combustion engines contains carbon monoxide and other harmful chemicals. Carbon monoxide is a colorless, odorless poison and can cause unconsciousness or death without warning. Long-term exposure to exhaust or chemicals in the exhaust can cause cancer, birth defects, and other reproductive harm. Avoid exposure to engine exhaust.

If engines are operated in confined spaces, maintain adequate ventilation or vent exhaust to the outside. Do not exceed applicable air contaminant limits. Injury to personnel can result if engine exhaust gases are not adequately ventilated.

Follow the inspection and maintenance schedule and procedures in this manual. Do not alter exhaust, ignition, or fuel systems.

WARNING **FIRE HAZARD**

The hot engine surfaces and exhaust of internal combustion engine powered lift trucks can present fire hazards when operating in areas containing flammable gases, vapors, liquids, dusts, fibers, or paper debris. Engine and exhaust component surface temperatures can exceed the ignition temperatures of common solvents, fuels, oil, paper, and other organic materials (wood, wheat, cotton, etc.). Exhaust emitted sparks can ignite these materials as well. Engine and exhaust surface temperatures increase after engine shutoff, presenting increased fire hazard. Check the engine compartment frequently in areas containing

Operating Procedures

HYSTER

combustible dust, fibers, or paper and remove any foreign materials. Contact your local Hyster dealer for forklift modifications that may be appropriate in environments with fire hazards.

Operate the lift truck only in areas that have been approved for lift truck operation.

Only the designated types of approved lift trucks may be used in areas classified as hazardous by the authority having jurisdiction. Areas classified as hazardous must be identified by signs to show the type of approved lift truck required for operation in the area. Modifications or poor maintenance can result in the lift truck being unsuitable for operation in areas classified as hazardous.

The fork lift truck is designed to pickup, move, and stack materials. The basic lift truck has a lift mechanism and forks on the front to engage the load. The lift mechanism lifts the load so that it can be moved and stacked.

In order to understand how the fork lift truck can pick up a load, you must first know some basic things about the lift truck.

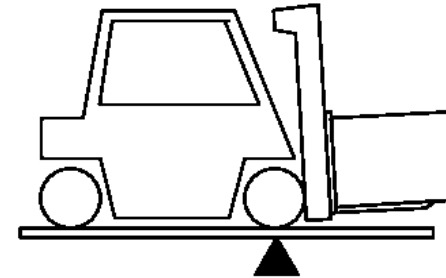

BO190107

The lift truck is based on the principle of two weights balanced on opposite sides of a pivot (fulcrum). This is the same principle used for a seesaw. In order for this principle to work for a lift truck, the load on the forks must be balanced by the weight of the lift truck. The location of the center of gravity of both the truck and the load is also a factor.

This basic principle is used for picking up a load. The ability of the lift truck to handle a load is discussed in terms of center of gravity and both forward and side stability.

HYSTER

Operating Procedures

Stability and Center of Gravity

The center of gravity (CG) of any object is the single point about which the object is balanced in all directions.

Every object has a CG. When the lift truck picks up a load, the truck and load have a new combined CG.

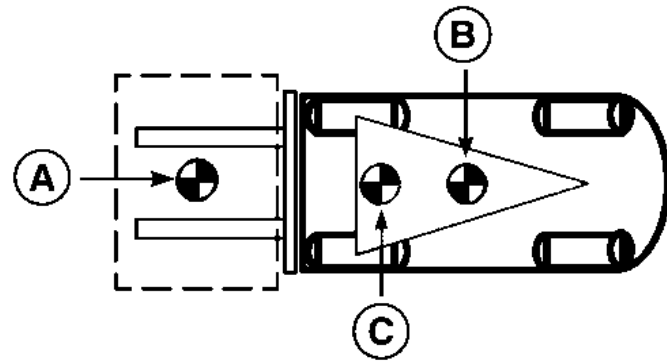
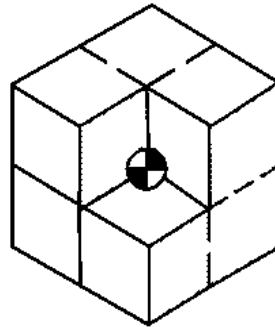

A. CG LOAD B. CG TRUCK C. COMBINED CG

The stability of the lift truck is determined by the location of its CG, or if the truck is loaded, the combined CG.

The lift truck has moving parts and therefore has a CG that moves. The CG moves forward and back as the mast is tilted

forward and back. The CG moves up and down as the mast moves up and down.

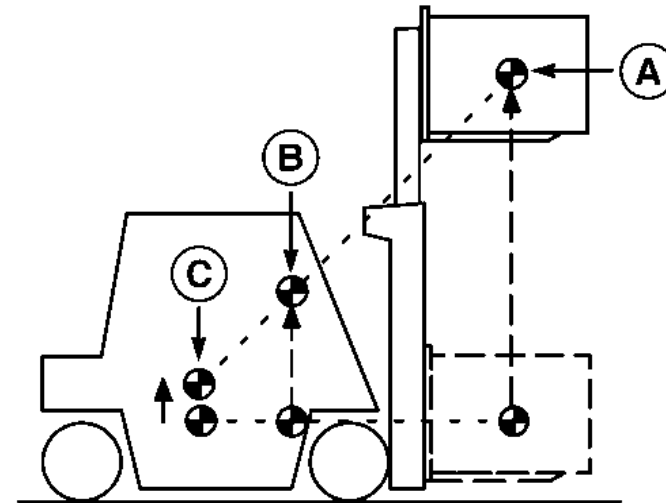

A. CG LOAD B. COMBINED CG C. CG TRUCK

The center of gravity, and therefore the stability of the loaded lift truck, is affected by a number of factors such as size, weight, shape, and position of the load; the height to which the load is raised; the amount of forward and backward tilt; tire pressure and the dynamic forces created when the truck is moving. These dynamic forces are caused by things like acceleration, braking, turning, and operating on uneven surfaces or on an incline. These factors must be considered when traveling with an unloaded



Operating Procedures

HYSTER

truck, as well, because **an unloaded truck will tip over to the side easier** than a loaded truck with its load in the lowered position.

In order for the lift truck to be stable (not tip over forward or to the side), the CG must stay within the area of the lift truck represented by a triangle drawn between the drive axle and the pivot of the steering axle.

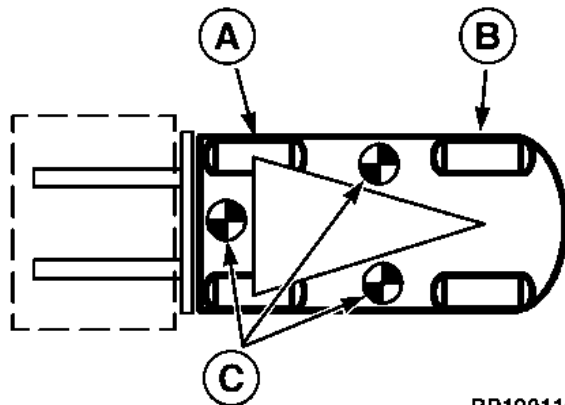

BP190110

A. DRIVE AXLE B. STEERING AXLE C. TRUCK WILL TIP OVER

If the CG moves forward of the drive axle, the lift truck will tip forward. If the CG moves outside of the line represented by the lines drawn between the drive wheels and the steering axle pivot, the lift truck will tip to that side.

Capacity (Weight and Load Center)

The capacity of the lift truck is shown on the Nameplate. The capacity is listed in terms of weight and load center. The weight is specified in kilograms and pounds. The load center is specified in millimeters and inches. The capacity is the maximum load that the lift truck can handle, with the mast vertical, for the load condition shown on the Nameplate.

⚠

**Trained Operators
and Mechanics only**

Read Operating Manual on seat or in operator compartment.

Failure to follow operating, inspection, and maintenance instructions can cause serious injury or death!

CAPACITY WITH MAST VERTICAL AND EQUIPPED AS SHOWN

LIFT TRUCK MODEL

Year of Manufacture

Serial No.

Attachment

Truck Weight kg Back Tilt Degrees

Tyre Front Rear

Size

Pressure

Tread Width mm

MAXIMUM CAPACITY	Load Height	Load Center	
	Dim. A	Dim. B	Dim. C
kg	mm	mm	mm
kg	mm	mm	mm

CE

BO190293

The load center of a load is determined by the location of its center of gravity. The load center is measured from the front face of the forks, or the load face of an attachment, to



HYSTER

Operating Procedures

the center of gravity of the load. Both the vertical and horizontal load centers are specified on the Nameplate.

Loads should be transported while centered on the center-line of the lift truck. The operator must know whether or not a load is within the maximum capacity of the lift truck before the load is handled.

Impact Sensor

The lift trucks covered in this **Operating Manual** may be equipped with an optional impact sensor that can be enabled or disabled by a service technician or a supervisor. The impact sensor will sense when the lift truck has hit an object, and will cause the lift truck to shutdown. There are two types of impact that the Vehicle System Manager (VSM) recognizes: soft impact and hard impact.

The data parameters that determine whether an impact is a soft or hard one are entered into the lift truck's VSM by personnel with a service or supervisor password (see Operator Passwords in this section).

If the impact sensor option is enabled and an impact has been detected, the following actions will occur:

- An alarm will sound. The duration of the alarm is set by a service technician or a supervisor.

- The message "Impact Shutdown" will be displayed on the top line of the LCD screen (see **Figure 6**) and the message "Engine Shutdown in XX" will be displayed on the bottom line of the LCD screen. XX represents the number of seconds before the engine shuts down and is factory set. If the delay is 0 seconds, the engine shuts down immediately and the message is not displayed.
- After delay (XX, above) has elapsed, the engine will immediately shutdown. The transmission and electro-hydraulic functions will also shutdown. If a load is in the raised position and needs to be lowered, see **Load Handling, Emergency Load Lowering** and **Figure 27** in this section to lower the load.
- The message "Impact Shutdown" will be displayed on the top line of the LCD screen and the message "Supervisor Required" will be displayed on the bottom line of the LCD screen.

The lift truck can be turned on again, after delay has elapsed, but the engine cannot be restarted until the Impact Sensor is reset by a supervisor or service technician (see **Engine Shutdown** in this section) for procedures to start lift truck after an engine shutdown). The messages "Impact Shutdown" and "Supervisor Required" will continue



Operating Procedures

HYSTER

to be displayed on the LCD screen. Pressing the STAR (*) key will display the password entry menu. If the Impact Alarm duration has been set to "Continuous," the alarm will continue to sound when lift truck power has been turned **ON**.

To clear messages, turn off alarm, and reset truck to normal operation, an Impact Reset must be performed by either a service technician or supervisor. See **Hyster Service Manuals User Interface, Supervisor 2200 SRM 1130** or **User Interface, Service 2200 SRM 1131** for procedures.

Inspection Before Operation

WARNING

Report damage or faulty operation immediately. Do not operate a lift truck that needs repair. A lift truck will only do its job when it is in proper working order. Injury to personnel can result if lift truck is operated when not in proper working order. If repairs are required, install a tag in the operator's area stating "DO NOT OPERATE" and remove the key from the key switch if truck is equipped with key switch option.



Checks With the Engine Stopped

Inspect the lift truck before use and every eight hours or daily as described in the **Maintenance** section of this **Operating Manual**. Inspect more frequently if used in severe operating conditions.

Before using the lift truck, make the following checks:

- Condition of forks, carriage, chains, header hoses, mast, attachment, and overhead guard.
- Condition of wheels and tires.
- Seat belt fastens correctly.
- Seat is correctly fastened to its mounts. Hood is correctly latched.
- Condition of the engine compartment. Ensure all surfaces are free of oils, lubricants, fuel, and organic dusts or fibers (paper, wood, cotton, agricultural grass/grain, etc.). Remove all foreign materials.
- Coolant level in the cooling system and condition of the drive belts.
- Condition of the radiator and screen. Clean if necessary.



HYSTER

Operating Procedures

- Fuel level.
- Oil level in the engine.
- Oil level in the hydraulic tank.
- Leaks from the engine, transmission, hydraulic system, and fuel system.
- Loose or missing hardware.
- Check transmission oil level.

Operator Checklist

If your lift truck is equipped with the optional operator checklist, it can be enabled or disabled by a supervisor or service technician.

The operator checklist will appear on the LCD screen after the lift truck has been powered **ON** and operator has entered the correct password, if the password function is activated. If password function is not activated, operator checklist appears after lift truck is powered **ON**.

The operator checklist can store a maximum of 30 items. Each item includes a text description of a system or component the operator is to check. The operator is instructed

to press button #1 for **YES** or button #2 for **NO** on the Display Switch Cluster. See **Figure 5**.

If any checklist item is answered with a **NO** response, the checklist item will be repeated. If a **NO** response is given again, the checklist item will be logged into the Checklist Log as a FAIL. When the checklist fails due to a **NO** answer, the display stops changing. No additional checklist items are shown.

Once the checklist has been completed and all items were answered with **YES**, the operator can start the lift truck. If there were any **NO** answers to checklist items, the truck may or may not start. The lift truck can be set up to not start (starter, engine outputs, transmission and hydraulic functions disabled) if any item in the checklist is answered with a **NO** response. If lift truck is configured this way, the message "Truck Disabled" will appear on the first line of the LCD screen and the message "Checklist Failed" will appear on the second line. The lift truck will stay disabled and messages will continue to appear on the LCD screen until lift truck has been reset by either a supervisor or service technician.

If lift truck is configured to start after a **NO** response had been given to a checklist item, the failure will be logged into



Operating Procedures

HYSTER

Checklist Log and operator will be allowed to start the lift truck.

Mounting and Dismounting

WARNING

To avoid serious injury when entering or exiting the lift truck, **ALWAYS USE 3 POINTS OF CONTACT. Maintain contact simultaneously with two hands and one foot or with two feet and one hand while climbing on or off the lift truck.**

Place feet carefully. Always face the lift truck when climbing on or off. Use added care when surfaces are slippery. Keep hands free of any obstacles such as food, beverages, or tools.

Lift Truck Interlocks

Certain operator actions, if not performed correctly while operating the lift truck, will cause traction and the hydraulic functions to become disabled.

DRIVE INTERLOCKS: Traction is enabled when the operator is in the seat (occupancy sensor), seat belt should be fastened, a direction of travel is selected, engine is running, and the parking brake is released. If any of the above

actions are not performed while operating the lift truck, traction will be disabled. To reactivate traction, the operator must return to the seat and press the brake pedal. Once the needed actions are completed, traction will be enabled and the operator can continue to load and unload material.

HYDRAULIC INTERLOCKS: The hydraulic functions are enabled when the operator is in the seat (occupancy sensor), seat belt should be fastened, and the engine is running. If any of the above actions are not performed while operating the lift truck, the hydraulic functions will be disabled. The LCD screen on the display panel will provide a non-service fault message "Hydraulic Interlock Engaged." To reactivate hydraulics, the operator must return to the seat and press the brake pedal. Once the needed actions are completed, the hydraulic function will be enabled and the operator can continue to load and unload material.

Operator Passwords

The lift trucks covered in this manual have an optional password feature.

The Operator Passwords are a series of five numbers. Each of the five number digits can be the numbers **1** through **5**. If enabled, the password number series must be entered into the memory by a technician or a supervisor



HYSTER

Operating Procedures

and assigned to an operator. Remember the password. A technician can use a personal computer (PC), connected to the vehicle, to check as well as assign the passwords.

There are four password types used on these trucks:

- **Operator:** Allows operator to operate lift truck.
- **Lockout Reset:** Lockout will occur when an operator incorrectly enters their password a specified number of times. After lockout occurs the following message will appear in the display, "Password Lockout" "Supervisor Required." The supervisor will enter the Lockout Reset password to unlock the system.
- **Supervisor:** Same rights as the Service Level password, except Supervisor Level password cannot add, change, or delete Service Level passwords.
- **Service:** Has all rights assigned to Operator, Lockout Reset, and Supervisor passwords. Can add, edit, and delete Operator, Supervisor, and Service passwords and view all truck diagnostic information. Allows access to truck service parameters within preset limits. On trucks with hood switch option, allows starting truck with hood open.

If the optional password feature is enabled and after the key is moved to the **ON** position, or the Power **ON/OFF** button is pressed, the LCD screen will show the message **PASSWORD ENTRY**. Use the numbered push buttons (see **Figure 5** and **Table 1**) to enter the five digit password and then press the STAR (*) button to enter the password and access main menu. If the password is entered incorrectly, and truck is not locked out, the message **PASSWORD INVALID** and **DISABLED IN ###**, with **###** being the number of attempts remaining before lockout occurs. The number of attempts is adjustable and set by a supervisor or service technician.

If the truck is locked out, the message **PASSWORD LOCKOUT, SUPERVISOR REQUIRED** is displayed. A Lockout Reset, Supervisor, or Service password is needed to unlock the lift truck. System power can be turned **OFF**, while in lockout mode by turning key switch to **OFF** or pressing the Power **ON/OFF** button. To reset a system lockout that occurs while attempting to enter a password within the on-board menu, after a correct operator password has been entered, recycle the system power. For all other lockout conditions, cycling the truck power will not reset the lockout.



Operating Procedures

HYSTER

Starting Procedures

Do not start or operate the lift truck, including any of its functions or attachments, from any place other than the designated operator's position.

If lift truck is equipped with the optional operator presence system, the following sequence must be followed for engine to start:

- Operator must be in seat
- Set belt must be fastened
- Make sure park brake is applied

If equipped, be sure cab door is secured in either the opened or closed position before starting lift truck operation.

WARNING

LPG is very flammable and can cause serious injury to personnel if ignited. An odor of LPG fuel can indicate a leak in the fuel system. DO NOT start the engine until the fuel leak is repaired and the atmosphere is free of LPG.

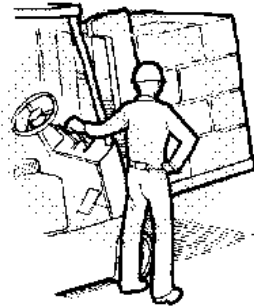

BO190112

1. If the lift truck uses LPG fuel, open the fuel valve on the LPG tank.
2. Make sure lift truck hood is closed.
3. Sit in operator's seat and fasten seat belt
4. Make sure the parking brake is applied.
5. If equipped, put the direction control lever for the transmission in the **NEUTRAL (N)** position.
6. Turn the key to the **ON** position or depress and release the Power **ON/OFF** button. If lift truck is equipped with a diesel engine and engine is cold, the cold start indicator light will illuminate and the cold start circuit will be energized.
7. If the truck is equipped with Operator Password feature, enter correct password.
8. If the truck is equipped with a diesel engine and the cold start indicator light is illuminate wait for the light to go out.
9. Turn the key to the **START** position or press and hold the Engine Start button to engage the starter. A countdown timer will appear on the LCD screen and limit the cranking time.



HYSTER

Operating Procedures

10. When the engine starts, check to see that the oil pressure lamp and charge lamp are off. If the lamps are still on, immediately stop the engine, and determine the cause before restarting.

11. Warm up the engine at medium speed without load.

If engine fails to start before the cranking countdown timer reaches zero, the starter will shut down for a cooling off period. A countdown timer will appear on the LCD screen showing the time remaining before another start can be tried.

To attempt another start procedures, repeat **Step 6** through **Step 11**.

Stop Procedures, Diesel Engine

On lift trucks equipped with a diesel engine, allow the engine to idle for 5 minutes before shutting it off after full load operation. Failure to do so may result in turbo charger damage.



Checks With the Engine Running

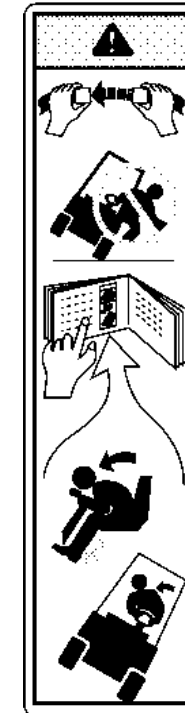

BO190113

⚠ WARNING
FASTEN SEAT BELT
If Lift Truck Tips Over

- Do Not Jump – Stay On Truck



Operating Procedures

HYSTER

- **Hold Firmly To Steering Wheel – Brace Feet – Lean Forward And Away From Impact**

The seat belt is installed to help the operator stay on the truck if the lift truck tips over. IT CAN ONLY HELP IF IT IS FASTENED.

The operator must be aware that the lift truck can tip over. There is a great risk that the operator or someone else can be killed or injured if trapped or hit by the truck as it tips over. The risk of injury can be reduced if the operator stays on the truck. **If the truck tips over, do not jump off!**

THE SEAT BELT AND HIP RESTRAINT bracket provides a means to help the operator keep the head and torso substantially within the confines of the truck frame and overhead guard if a tipover occurs. This protection system is intended to reduce the risk of the head and torso being trapped between the truck and the ground, but it can not protect the operator against all possible injury in a tipover.

Make sure that the area around the lift truck is clear before starting the engine or making any operational checks. Be careful when making the checks. If the lift truck is stationary during a check, apply the parking brake and make sure the direction control is in **NEUTRAL**. Proceed carefully.

Check the operation of the following functions as described in the **Maintenance** section:

- Check the operation of the horn and indicator lights.
- Operate the **LIFT, TILT**, and auxiliary functions to check for correct operation of the mast, carriage, and attachments.
- Check the operation of the MONOTROL® pedal or the optional direction control lever and accelerator pedal.
- Check the operation of the service brakes and parking brake.
- Check the operation of the steering system.
- Check the oil level in the transmission when the oil is at operating temperature 50 °C (120 °F). Turn the truck off and wait one minute. Then check the transmission oil level.

Load Weighing Sensor

If your lift truck is equipped with the optional load weight sensor, it can display the weight of the load in either pounds or kilograms on the LCD screen (see **Figure 6**). The unit of measure is preset by a service technician or a



HYSTER

Operating Procedures

supervisor and can be changed by a service technician or supervisor.

The operator can access the load weight function by pressing the up or down arrow keys on the Display Switch Cluster (see **Table 1**), until the word "Weight" appears on the LCD screen. See **Figure 6**.

To most accurately weigh a load, follow these instructions:

1. With a load on the forks, position the mast in a vertical position.
2. Lift the load 0.6 m (2 ft) off the ground, but if free-lift cylinder is present, not more than maximum free lift.
3. Lower the load 51 mm (2 in.). Stop lowering, wait 1 second, and read the load weight. This will be the most accurate weight. Waiting longer to read the load weight will reduce accuracy.

Set Load Weight to Zero

The service technician or supervisor can set the load weight to zero, when the no-load weight displayed on the LCD screen (see **Figure 6**) is not within $\pm 2\%$ of truck capacity. See **User Interface - Supervisor 2200 SRM**

1130 or **User Interface - Service Technician 2200 SRM** 1131 for procedures.

Engine Shutdown

NOTE: The information in this section pertains to lift trucks with the powertrain protection option. On trucks without powertrain protection, the fault number is displayed on the LCD screen and the Engine Malfunction icon will illuminate, but engine will not shutdown or truck performance will not be decreased. **DO NOT continue to run lift truck. Turn engine OFF and notify service technician immediately for repair.**

Certain faults or sensor measurements can cause the truck to go into Engine Shutdown mode. The following actions occur when truck is in this mode:

- The fault number is displayed on the top line of the LCD screen and a 30-second countdown timer is shown on the bottom line.
- An alarm will sound during the 30-second countdown and continue for 10 seconds afterwards.
- The Engine Malfunction icon illuminates. If engine shutdown was caused by low coolant level, low engine oil pressure, high coolant temperature, or high transmission



Operating Procedures

HYSTER

oil temperature, the appropriate icon will also be illuminated. See **Figure 6** and **Table 1**.

At the end of the 30-second countdown, all power to the lift truck is turned off. After shutdown has occurred, recycle power to **ON**, load can then be lowered without starting the engine.

CAUTION

If lift truck experiences an engine shutdown, call a service technician immediately. Continued operation of lift truck after engine shutdown can cause damage to the lift truck and its components.

To restart the lift truck, turn the key switch **OFF** and **ON** again to cycle the system power. If lift truck is equipped with the Power **ON/OFF** button, press Power **ON/OFF** button twice to cycle the system power and then press the Engine Start button. If the Engine Start button is pressed before the Power **ON/OFF** button, the starter will not operate. See **Starting Procedures** in this section, if starter becomes disabled.

When the lift truck has been restarted, it will run for 30 seconds before shutting down again. Cycle the truck power again to run the lift truck for another 30 seconds. This proc-

ess provides enough power for the lift truck to move under its own power so that it can be moved to a safe location.

Some faults or sensor measurements will not always cause the engine to shutdown, but will cause the speed of the lift truck to be restricted, or will either disable or restrict the truck's hydraulic functions.

When this occurs, the following actions take place:

- The fault number is displayed on the top line of the LCD screen and a description of truck performance being decreased is shown on bottom line.
- The Engine Malfunction icon illuminates (see **Figure 6** and **Table 2**).
- An alarm will sound for 10 seconds.

Take the lift truck to a service technician immediately for repair if it experiences a decrease in performance.



HYSTER

Operating Procedures

Operating Techniques

⚠ WARNING

Before operating the lift truck, **FASTEN YOUR SEAT BELT.**

Failure to fasten seat belt may result in injury to personnel.



BO190114

There are a number of operations, if not performed carefully, that can cause the lift truck to tip. If you have not read the **WARNING** page in the front of this Operating Manual, do so **NOW**. As you study the following information about how to properly operate a lift truck, remember the **WARNINGS**.

NOTE: Lift trucks covered in this manual are equipped with the Emergency Locking Retractor (ELR) style seat belt. When the ELR seat belt is properly buckled across the operator, the belt will permit slight operator repositioning without activating the locking mechanism. If the truck tips, travels off a dock, or comes to a sudden stop, the locking mechanism will be activated and hold the operator's lower torso in the seat.

Basic Operating Procedures

Many people make the mistake of thinking that operating a lift truck is the same as driving an automobile. This is not true. A lift truck is a special machine designed to do a much different job than an automobile. Because of the close areas in which a lift truck operates and its other operating characteristics (like rear wheel steering and tail swing), every operator must receive additional training, even if they have a license to drive an automobile.

The following discussion lists basic procedures applicable to lift truck operation.



BO190115

- 1. AUTHORIZED AND TRAINED OPERATOR ONLY.** This means the operator must be trained to drive the lift truck and it means that the operator must thoroughly understand the procedures for lift truck operation. It also means that

a qualified person experienced in lift truck operation must guide the operator through several driving and load handling operations before the operator attempts to operate the lift truck alone. A basic education in proper driving and load handling techniques is absolutely necessary to



Operating Procedures

HYSTER

prepare the new operator for proper defensive driving and to expect the unexpected.

WARNING

This lift truck is designed for handling materials. A lift truck is not designed to lift people. Do not use a lift truck to lift people unless it has been determined that there is no other practical option (scaffolds, elevated work platforms, aerial baskets, etc.) to perform the needed work.

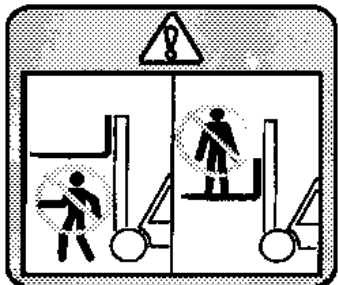

BO190117

If a lift truck is used to elevate a worker, a safety platform must be attached to the forks and carriage. The platform must have a solid floor with a surface to prevent the feet of the worker from slipping, hand rail, toe board, and a screen or shield at least 2 m (7 ft) high

between the people on the platform and the lift mechanism.

The combined weight of the platform, load, and personnel is not to exceed one-half of the capacity as indicated on the nameplate of the truck on which the platform is used.

Before anyone is allowed in the platform, lift and lower the mast slowly with the platform in place to make sure the mast functions properly. Apply the parking brake. Do not travel with people in the platform. The operator must remain at the controls. Watch for overhead obstructions.

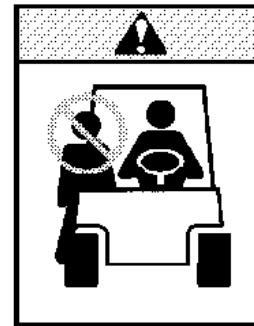

BO190116

2. NO RIDERS. A lift truck is built for only one person – the operator. It is dangerous for anyone to ride on the forks or anywhere else on the lift truck.

3. ADJUST SEAT - INTERNAL SUSPENSION.

Seat Position Adjustment (Swivel Seat)

- The seat swivels 10.5 degrees to the right to allow the operator a more ergonomic position when driving in reverse.
- The seat swivels 5 degrees to the left to allow an easier exit of the truck.
- The neutral position is shown in **Figure 24**.

HYSTER

Operating Procedures

Seat Adjustment for Operator Weight

CAUTION

A major cause for high Whole Body Vibration is caused by the operator not adjusting the seat to his/her weight.

NOTE: It is important to adjust the weight setting for each operator.

NOTE: The seat is designed for a maximum weight of 135 kg (298 lb)

- The target is for the "ride indicator" to fall between the arrows when the operator sits upright in the seat with the feet positioned on the pedals. This ensures that the operator is set at the midpoint of the 40 mm (1.57 in.) suspension.
- The weight adjustment knob can be turned left or right to increase or decrease the weight resistance. As the weight adjustment knob is turned the "stiffness" of the suspension can be felt to increase or decrease depending on which way the weight adjustment knob is turned.

- The measured vibration levels measured to EN13059 are noted in the front of this manual in the **Foreword** section.

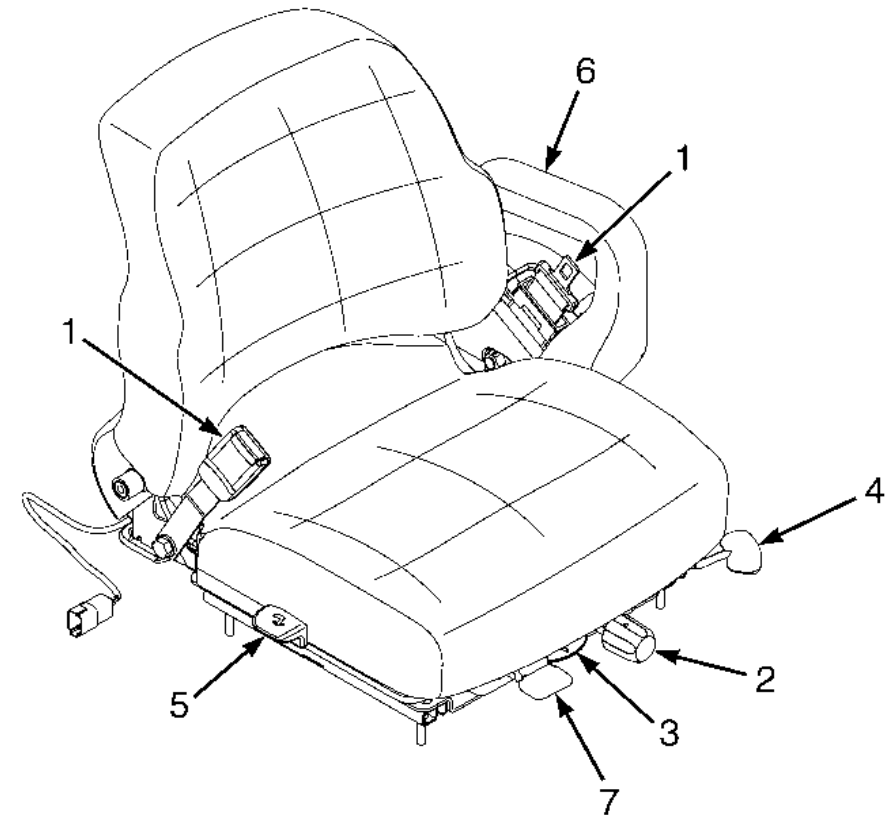

BO190630

Figure 24. Seat Adjustment - Internal Suspension



Operating Procedures

HYSTER

Legend for Figure 24

- | | |
|---|----------------------------------|
| 1. SEAT BELT | 5. BACKREST ANGLE |
| 2. WEIGHT ADJUSTMENT
KNOB | ADJUSTMENT LEVER |
| 3. RIDE POSITION
INDICATOR | 6. ARMREST |
| 4. FORWARD/BACKWARD
ADJUSTMENT LEVER | 7. SWIVEL LATCH RELEASE
LEVER |

4. ADJUST SEAT - FULL SUSPENSION.

Seat Position Adjustment (Swivel Seat)

- The seat swivels 12 degrees to the right to allow the operator a more ergonomic position when driving in reverse.
- The seat swivels 5 degrees to the left to allow an easier exit of the truck.
- The neutral position is shown in **Figure 25**.

Seat Adjustment for Operator Weight



CAUTION

A major cause for high Whole Body Vibration is caused by the operator not adjusting the seat to his/her weight.

NOTE: It is important to adjust the weight setting for each operator.

NOTE: The seat is designed for a maximum weight of 135 kg (298 lb)

- The target is for the "ride indicator" to fall between the arrows when the operator sits upright in the seat with the feet positioned on the pedals. This ensures that the operator is set at the midpoint of the 80 mm (3.5 in.) suspension.
- The handle can be turned as shown to increase or decrease the weight resistance, pull handle out before turning. As the handle is turned the "stiffness" of the suspension can be felt to increase or decrease depending on which way the handle is turned.
- The measured vibration levels measured to EN13059 are noted in the front of this manual in the **Foreword** section.

HYSTER

Operating Procedures

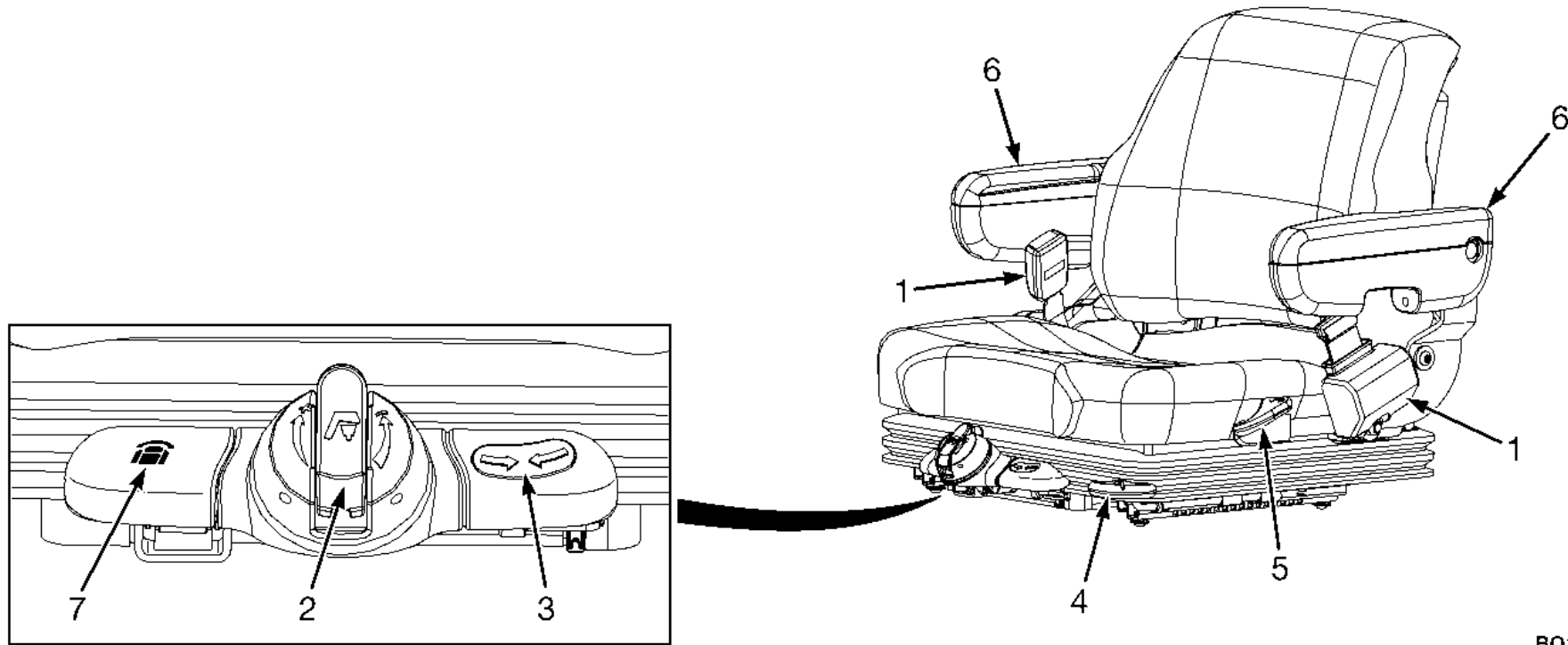

BO190622

1. SEAT BELT
2. WEIGHT ADJUSTMENT KNOB
3. RIDE POSITION INDICATOR
4. FORWARD/BACKWARD ADJUSTMENT LEVER

5. BACKREST ANGLE ADJUSTMENT LEVER
6. ARMREST
7. SWIVEL LATCH RELEASE LEVER

Figure 25. Seat Adjustment - Full Suspension



Operating Procedures

HYSTER

5. Do not drive a lift truck into an elevator unless authorized to do so. Approach the elevator slowly. After the elevator is properly leveled, the lift truck must be centered so that the elevator is balanced.

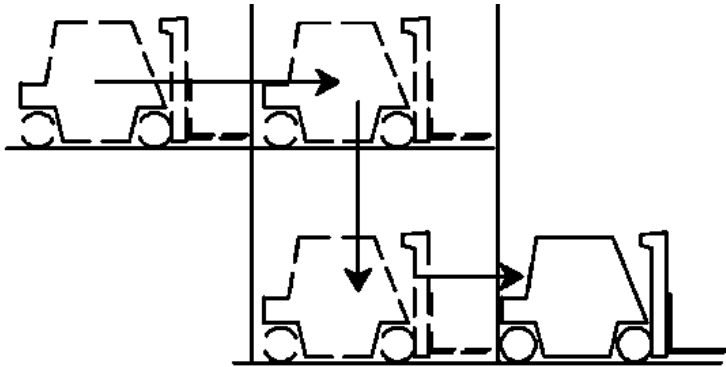

BO190118

When the lift truck is in the proper position in the elevator, set the brakes, put the controls in **NEUTRAL** and shut off the power. It is advisable that all other personnel leave the elevator before the lift truck enters or leaves.

6. Drive carefully, observe traffic rules, and be in full control of the lift truck at all times. Be completely familiar with all the driving and load handling techniques contained in this **Operating Manual**.



Driving and Direction Changes

KNOW YOUR TRANSMISSION OPTION. The lift truck models covered in this manual can be equipped with either a Powershift 2 Speed Transmission, DuraMatch Transmission (3-speed), a DuraMatch Plus Transmission (3-speed), Powershift Transmission, DuraMatch Transmission, or DuraMatch AH Transmission. Read the following sections carefully. See **Table 5** and **Figure 26** for the features and operational differences in these transmission types.



HYSTER

Operating Procedures

Table 5. Transmissions

Operational Feature	Powershift 2 Speed or Powershift	DuraMatch (3-Speed)	DuraMatch Plus (3-Speed) or DuraMatch AH
Electronic Inching	No	Yes	Yes
Auto Deceleration	No	Yes	Yes
Electronic Control of Direction Changes	Yes	Yes	Yes
Controlled Power Reversal	No	Yes	Yes
Roll Back Feature	No	Yes	Yes
Roll Reduction Feature	No	Yes	Yes
Reduced Drive Tire Slippage	No	Yes	Yes
Throttle Up	No	No	Yes



Operating Procedures

HYSTER

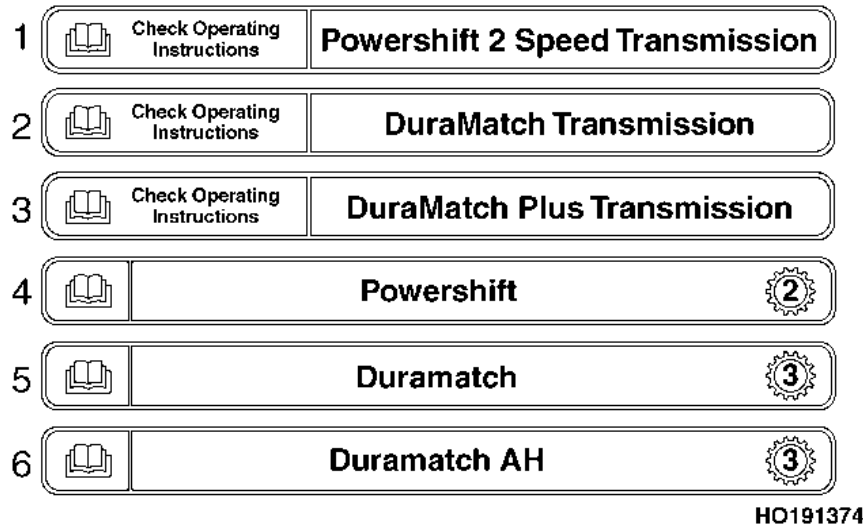

1. POWERSHIFT 2 SPEED TRANSMISSION LABEL
2. DURAMATCH TRANSMISSION LABEL
3. DURAMATCH PLUS TRANSMISSION LABEL
4. POWERSHIFT LABEL
5. DURAMATCH LABEL
6. DURAMATCH AH LABEL

Figure 26. Transmission Labels

General

The lift truck can have either a MONOTROL® pedal or a Direction Control Lever to control the transmission. The selected direction of travel is shown on the display switch cluster. See **Figure 6**. If the lift truck has a MONOTROL®

pedal, push on the left side of the pedal to go **FORWARD**, or the right side of the pedal to go in **REVERSE**. If the lift truck has a direction control lever, move the lever toward the front of the lift truck to go **FORWARD** and toward the rear of the lift truck to go in **REVERSE**.

Normal Operations

In normal operating conditions, either at start or while driving, the lift truck can only be maintained at a stopped position by applying the service brake or parking brake.

When moving away from a stop:

1. Select direction while maintaining braking.
2. Depress the accelerator or MONOTROL® pedal.
3. Release the brakes (parking and/or service brake)

Depress the accelerator or MONOTROL® pedal to ensure the lift truck will move in the selected direction when the brakes are released.

Due to variable load and grade conditions, this procedure minimizes the possibility of the lift truck traveling in a direction opposite to the one selected.



HYSTER

Operating Procedures

Standard Operator Presence System

WARNING

Always make sure the parking brake is fully applied before leaving the lift truck. If the operator leaves the lift truck without applying the parking brake, a seat activated switch will shift the transmission to neutral, and sound an alarm for 10 seconds. If the lift truck is left on a grade, without the parking brake fully applied, the lift truck will freewheel down the grade, possibly causing injury or property damage.

The lift trucks covered in this **Operating Manual** are equipped with an Operator Presence System (OPS). The OPS feature has an electrical switch in the seat which senses the presence of the operator. This allows the transmission in internal combustion engine trucks to be engaged only when the operator is in the seat. The OPS is designed with slight delay in the seat switch to allow the operator to reposition himself without disengaging the transmission. When the seat switch disengages the transmission (neutral position), the operator must depress the service brake pedal to re-engage the traction (travel mode).

A switch in the operator's seat will automatically shift the transmission to neutral within 1-2 seconds when the opera-

tor leaves the seat of the lift truck with the engine running and without applying the parking brake.

If the lift truck is equipped with a Direction Control Lever and the operator leaves the seat without engaging the parking brake, the **N** indicator light on the Display Switch Cluster will illuminate regardless of the position of the Direction Control Lever. When the operator returns to the seat, to resume travel, the Direction Control Lever must be moved to the **N** position, then to the desired direction of travel.

If the lift truck is equipped with a MONOTROL® pedal and the operator leaves the seat without engaging the parking brake, the **N** indicator light on the Display Switch Cluster will illuminate regardless of the position of the MONOTROL® pedal. When the operator returns to the seat, the indicator light will change from **N** to the direction of travel that the MONOTROL® pedal was last in when the operator left the lift truck. The operator can resume travel by depressing the MONOTROL® pedal.



Operating Procedures

HYSTER

Optional Operator Presence System

WARNING

ALWAYS make sure the parking brake is fully applied before leaving the lift truck. If the operator leaves the lift truck without applying the parking brake, a seat activated switch will cut off traction and hydraulic power to the lift truck.

Lift trucks produced after March, 2009 are equipped with an Operator Presence System (OPS). The OPS feature uses an electrical switch in the seat which senses the presence of the operator, and interlocks to prevent the use of hydraulic functions. This allows the mast hydraulic control functions to be engaged only when the operator is in the seat. The OPS is designed with a delay in activating the interlock to allow the operator time to reposition himself without disabling the hydraulic controls.

The seat switch will automatically disable hydraulics within 1-2 seconds when the operator leaves the seat of the lift truck. When the seat switch disables the hydraulic functions, the operator must sit in the seat and depress the service brake pedal to re-engage hydraulic functions.

Powershift 2 Speed Transmission or Powershift Transmission

WARNING

DO NOT select the travel direction if the accelerator is depressed. The lift truck will move rapidly and can cause damage or injury.

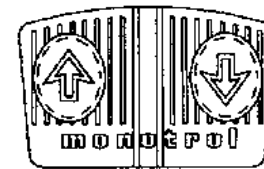

A

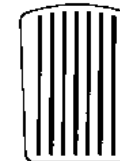

B



C

HO190512

- A. MONOTROL® PEDAL
- B. ACCELERATOR PEDAL
- C. DIRECTION CONTROL INDICATOR LIGHTS

CAUTION

The drive train can be damaged if the lift truck is traveling too fast when the controls are changed to the opposite direction of travel.

The operator can change the direction of travel at slow travel speeds (less than a walking speed), but the mast



HYSTER

Operating Procedures

must not be in a raised position. If the lift truck is moving rapidly, slow to a walking speed before changing the direction of travel.

DuraMatch, DuraMatch Plus, and Duramatch AH Transmissions

The DuraMatch, DuraMatch Plus, and Duramatch AH Transmissions are equipped with Controlled Power Reversal, Auto Deceleration, Roll Reduction, Roll Back, and Reduced Drive Tire Slippage features. See **Table 5**. Operators should be trained and become familiar with these operating features before transporting loads.

The DuraMatch Plus and Duramatch AH (three speeds forward, two speeds reverse) transmission contain the same features as the DuraMatch transmissions, and also two more features: Auto-Speed Hydraulics and Throttle Response Management. See **Table 5**.

Controlled Power Reversal

WARNING

The factory settings are set for most load handling applications, but may require adjustment for special applications to avoid load damage or personal injury due to rapid direction reversals and unstable loads.

The factory settings for the Controlled Power Reversal feature can be changed by a Hyster Service Technician when required to meet special application requirements.

The DuraMatch and DuraMatch Plus transmissions allow the operator to change direction at any travel speed without damaging the transmission. The operator should always consider the load that is being carried, and keep the carriage lowered, when making a controlled power reversal or using transmission braking. The operator is responsible for control of the truck and the stability of the load.

When a direction change is selected, the lift truck's Vehicle Management System (VSM) automatically reduces engine speed to idle and activates transmission braking. The operator controls the level of transmission braking, or deceleration, with the use of the accelerator or MONOTROL® pedal. Depressing the accelerator or MONOTROL® pedal increases the amount of transmission braking before the lift truck begins to move in the opposite direction. Releasing the accelerator or MONOTROL® pedal after selecting a direction change, reduces the amount of transmission braking. Application of the service brakes allows the operator to bring the lift truck to a complete stop at any time. Once the truck stops and travel direction changes, the normal control



Operating Procedures

HYSTER

of the accelerator or MONOTROL® pedal returns. The operator should always consider the load that is being carried, and keep the carriage lowered, when making a controlled power reversal or using transmission braking.

Auto-Deceleration Feature

WARNING

The factory settings are set for most load handling applications, but may require adjustment for special applications to avoid load damage or personal injury due to rapid direction reversals and unstable loads. The factory settings for the Auto-Deceleration feature can be changed by a Hyster Service Technician when required to meet special application requirements.

Provides transmission braking, or deceleration, when the accelerator or MONOTROL® pedal is released at vehicle travel speeds greater than walking speed. The amount of deceleration is controlled by the accelerator or MONOTROL® pedal position. Releasing the accelerator or MONOTROL® pedal causes a greater amount of transmission braking. Depression of the accelerator or MONOTROL® pedal increases acceleration. The operator should always consider the load that is being carried, and keep the carriage lowered, when using transmission braking.

Roll Reduction Feature

WARNING

The lift truck is only considered at a controlled stop when the truck is not rolling and the service or parking brake is applied. The operator cannot rely on transmission braking alone to bring the lift truck to a full controlled stop. Failure to use the service or parking brakes could result in damage to the lift truck and/or injury to personnel.

Provides limited transmission braking to stop the lift truck from rolling on level ground or to limit vehicle speeds to less than slow walking speed on minor grades. This feature will attempt to stop the lift truck when the transmission is in either **FORWARD** or **REVERSE**, and both the accelerator or MONOTROL® pedal and inching/brake pedals are released. The transmission cannot stop the lift truck in all conditions. It is the operator's responsibility to use the service or parking brake to stop and hold the lift truck from moving.

Roll Back Feature

If the operator uses the brakes to bring the lift truck, regardless of direction selected, to a stop on a grade; then



HYSTER

Operating Procedures

releases the brake, the Roll Back feature limits and controls the speed at which the truck rolls backward or forward. This feature is effective on grades up to 10% and limits the speed to 7.6 cm (3 in.) per second. (The lift truck may roll faster than 7.6 cm (3 in.) per second until the Roll Back feature slows it down.)

Reduced Drive Tire Slippage

Electronically controls engine power and clutch pack engagement during acceleration and reduces the possibility of drive tire wheel spin.

Auto-Speed Hydraulic Feature

When lift truck hydraulic functions are activated, lift truck will electronically increase engine speed to meet the increase in hydraulic flow. At the same time, lift truck speed will stay the same and be independent from hydraulic functions.

Throttle Response Management

Electronically controls the drive torque by limiting engine speed to prevent tire slippage and over torque in the transmission.

Inching

WARNING

Inching requires coordinated movement of the inching/brake pedal and the accelerator or the MONOTROL® pedal. New operators must practice this procedure before attempting to handle loads.

If inching is not done correctly, damage to material and lift truck and injury to personnel can occur.

Inching is the movement of a lift truck that allows a slow travel speed while keeping the engine speed high for fast operation of the lift mechanism.

The inching/brake pedal is used to control the inching operation. When the inching/brake pedal is initially applied, the clutch in the transmission is partially disengaged and the movement of the truck is slow. When the inching/brake pedal is fully applied, the transmission is completely disengaged and the brakes are applied. Use the accelerator pedal or MONOTROL® pedal to keep the engine speed high while inching.

Operating Procedures

HYSTER

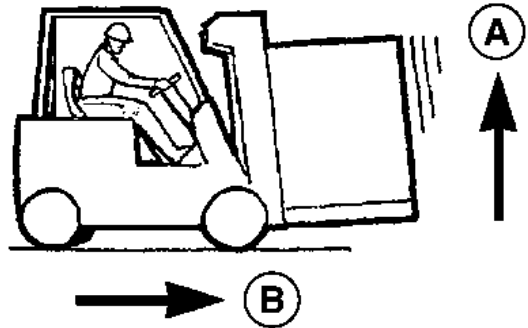

BO190120

A. FAST

B. SLOW

Steering (Turning)

⚠ WARNING

TRAVEL SLOWLY WHEN TURNING. Lift trucks can tip over even at very slow speeds. The combination of speed and the sharpness of a turn can cause a tipover. A lift truck is less stable when the forks are elevated, with or without a load.

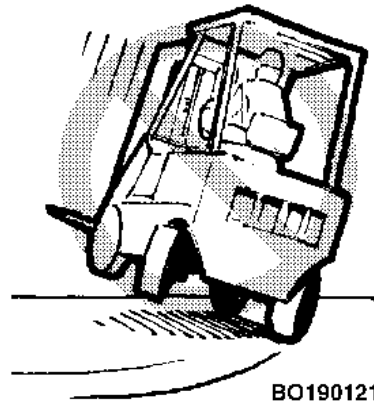

BO190121

⚠ WARNING

IF THE LIFT TRUCK TIPS OVER, DO NOT JUMP OFF! HOLD FIRMLY TO STEERING WHEEL, BRACE YOUR

FEET, AND LEAN FORWARD AND AWAY FROM THE POINT OF IMPACT.

If the above steps are not followed during a lift truck tipover, injury to personnel can occur.

Most operators can understand the need to be careful when handling loads. But some operators do not realize that a tipover can occur with an empty lift truck because similar dynamic forces are present. In fact, the lift truck will actually tip over easier when empty, than when loaded with the load lowered. Mast tilt, off-center loads, and uneven ground will aggravate these conditions and cause the forklift to become unstable.

⚠ WARNING

Failure to observe the tail swing area when making a turn can injure or kill someone.

HYSTER

Operating Procedures

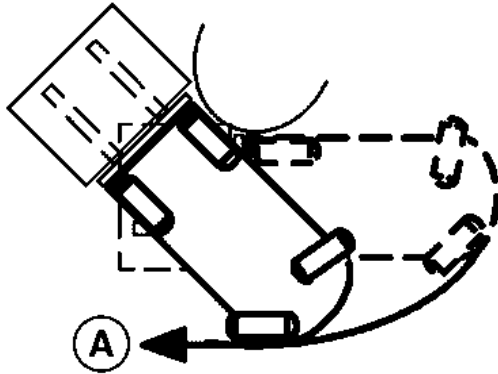

BO190122

A. TAIL SWING

Because lift trucks are designed to work in a relatively small space, they can turn sharper than some other vehicles. Most lift trucks are steered by the rear wheels and the rear of the lift truck can move to the side very fast during a turn. This movement is called "tail swing". An operator must be aware of tail swing and always check to make sure the tail swing area is clear before turning. Failure to observe the tail swing area when making a turn can lead to injury or death.

Do not turn on an incline. To reduce the possibility of a tipover, a lift truck must not be driven across an incline.

When possible, keep both hands on the steering wheel. During most loading or unloading operations, the operator steers with the left hand.

The right hand is used to operate the lift, tilt, and attachment controls.

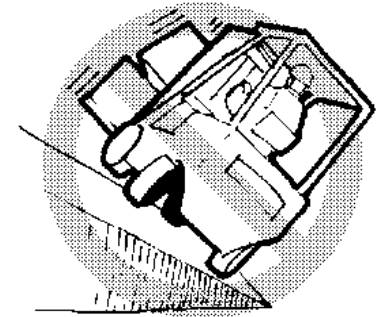

BO190123

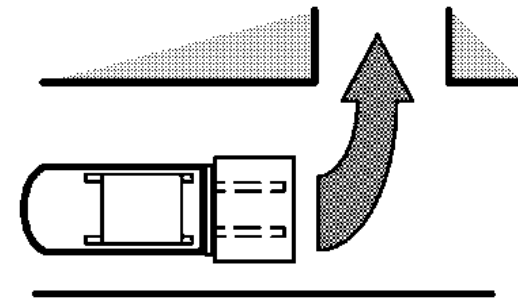

BO190125

When turning the lift truck from a wide aisle into a narrow aisle, start the turn as close to the opposite stock pile as tail swing will permit. This action permits the lift truck to enter the narrow aisle going straight ahead.



Operating Procedures

HYSTER

Load Handling, General

1. The capacity is the maximum load that the lift truck can handle for the load condition shown on the Nameplate. The operator must know whether or not a load is within the maximum capacity of the lift truck before the load is handled.

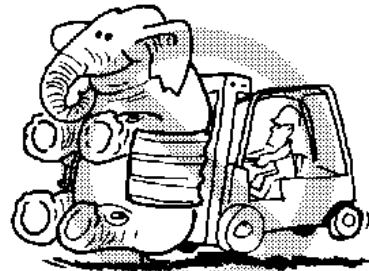

BO190124

However, factors such as weak floors or uneven terrain, loads with a high center of gravity, unevenly distributed loads, or tire condition can mean that the safe working load is less than the capacity shown on the Nameplate. When such conditions exist, the operator must reduce the load so the lift truck will remain stable.

⚠ WARNING

Do not handle a load if any loose part of it is above the load backrest or any part of the load is likely to fall. Injury to personnel and damage to lift truck and materials may occur.

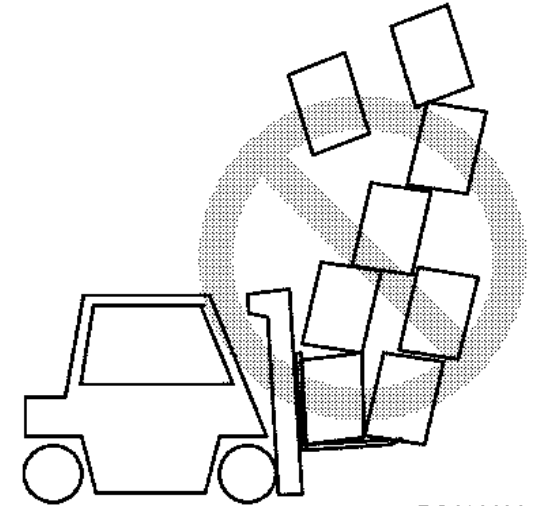

BO190126

2. Handle only stable loads. A load can have unstable items that can easily shift and fall on someone.

3. Position each fork the same distance from the center of the carriage. This action will help center the load on the carriage. Set the forks as far apart as possible for maximum support of the load. Center the weight of the load between the forks.

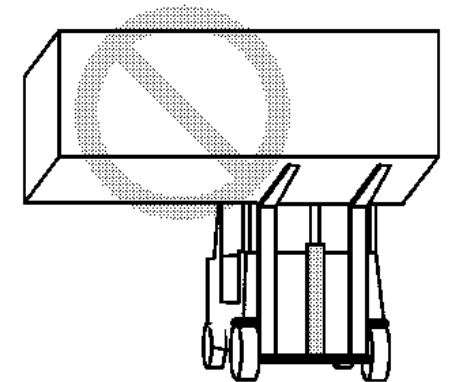

BO190127

If the weight of the load is not centered between the forks, the

HYSTER

Operating Procedures

load can fall from the forks when you turn a corner or hit a bump. An off-center load will increase the possibility of the truck tipping over to the side. Make sure the pins that keep the forks in position are engaged so that the forks cannot move.

4. Check the condition of the driving surface. Make sure the floor will support the weight of the lift truck and the load.

Load Handling, Lifting, Lowering, and Tilting

NOTE: The lift trucks covered in this manual are equipped with Electro-Hydraulic (E-Hydraulic) mini-levers (see **Figure 22** and **Table 3**).

The **LIFT** and **TILT** functions are controlled by separate levers. See **Operator Controls step** in the **Model Description** section for the correct operation.

The speed of the hydraulic functions is controlled by the position of the mini-levers. The farther the mini-lever is moved from the **NEUTRAL** position, the faster the speed of the hydraulic function.

Do not lift or hit anything that can fall on the operator or a bystander. Remember, a lift truck equipped with a **Hyster** overhead guard and load backrest extension provides rea-

sonable protection to the operator from falling objects, but can not protect against every possible impact.

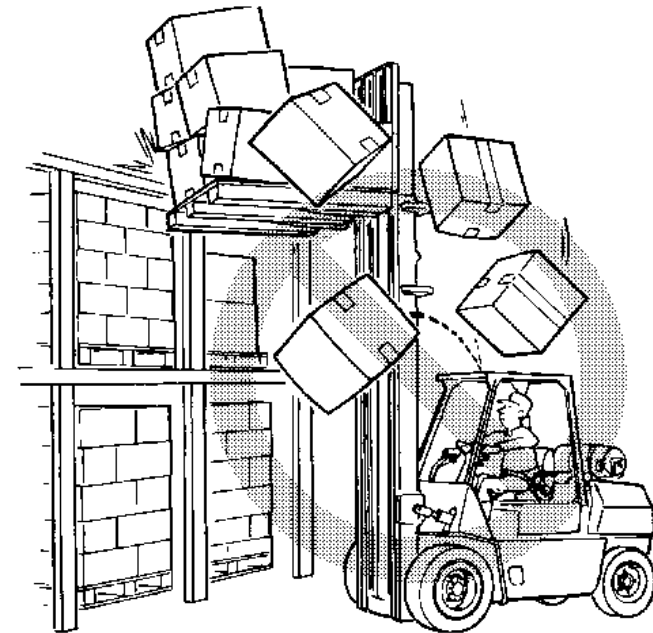

B0190128

A lift truck without an overhead guard provides no such protection and other personnel have no overhead protection. Avoid hitting objects such as stacked material that could become dislodged and fall.

The operator must exercise care while working near such objects. Whether the lift truck is loaded or empty, do not travel with the load or carriage in a raised position.

Operating Procedures

HYSTER

⚠ WARNING

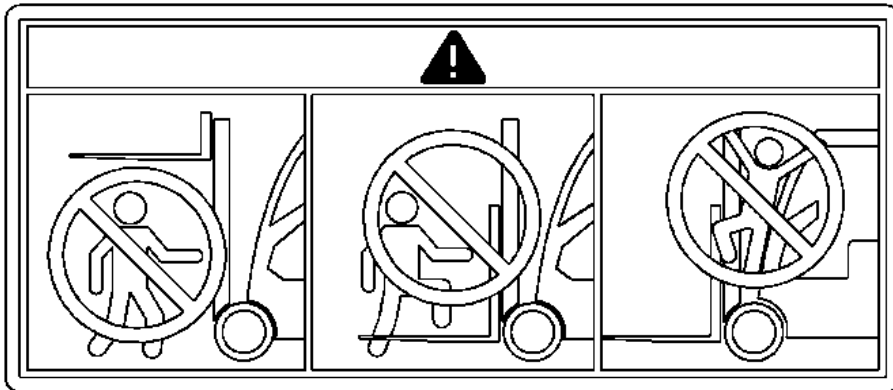

BO190290

Keep yourself and all others clear of the lift mechanism. Never allow anyone under or on the forks.

⚠ WARNING



NEVER put hands, arms, head, or legs through the mast or near the carriage or lift chains. This warning applies not only to the operator but also a helper. A helper must not be near the load or lift mechanism while the operator is attempting to handle a load. The

lift mechanism has moving parts with close clearances that can cause serious injury.

Lift and lower with the mast vertical or tilted slightly backward from vertical. Tilt elevated loads forward only when directly over the unloading place.

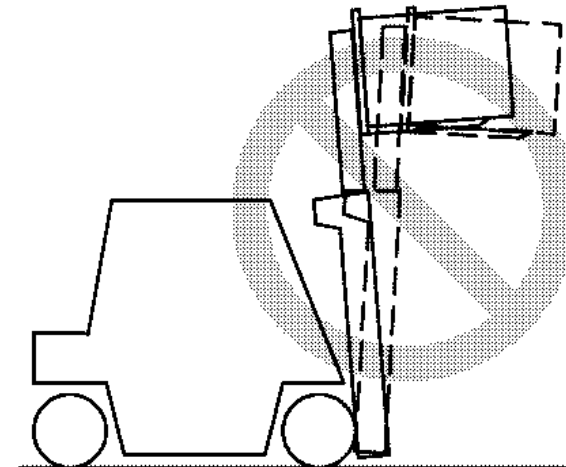

⚠ WARNING

The lift truck can tip over forward when the load is raised and cause serious injury to personnel and damage equipment and material.

NOTE: Forward tipping is even more likely when tilting forward, braking when traveling forward, or accelerating in reverse.

HYSTER

Operating Procedures

If the lift mechanism is raised to pick up or deposit a load, keep the tilt angle in either direction to a minimum. Backward and forward tilt are helpful, but they affect side and forward stability. Do not tilt in either direction more than necessary when handling a load that is raised. The lift truck can tip forward if the mast is tilted forward with a load in the raised position.

WARNING

IF THE LIFT TRUCK TIPS OVER, DO NOT JUMP OFF! HOLD FIRMLY TO STEERING WHEEL, BRACE YOUR FEET, AND LEAN FORWARD AND AWAY FROM POINT OF IMPACT.

If the above steps are not followed during a lift truck tipover, injury to personnel can occur.

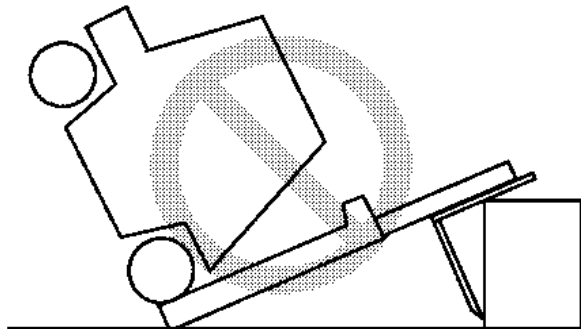

Load Handling, How to Engage and Disengage a Load

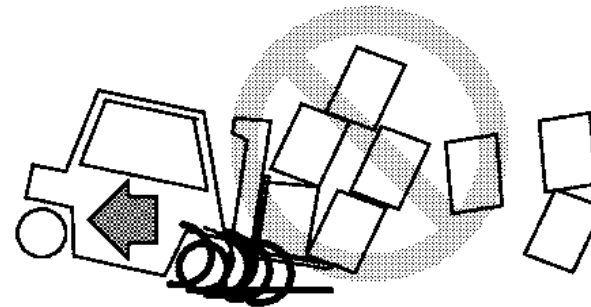

1. Avoid fast starts. Sudden movement can cause the lift truck to tip. People can be hurt or killed and material can be damaged.

Approach the load carefully. Make sure that the truck is perpendicular to the load. Raise the forks to the proper height for engaging the load.

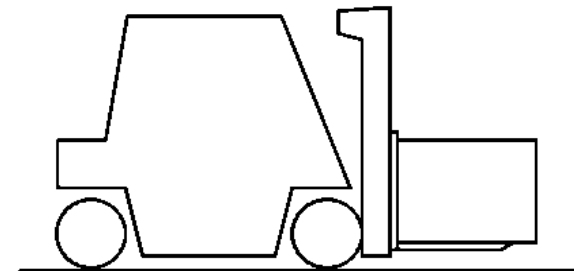

2. Move forward slowly until the forks are in position under the load. The forks must support at least two-thirds (2/3) of the length of the load.



Operating Procedures

HYSTER

Make sure that the load is centered between the forks. Make sure that the forks do not extend past the load so that loads or equipment that are behind the load being lifted are not damaged. Lift the load a small distance from the floor to make sure the lift truck has the capacity to lift the load.

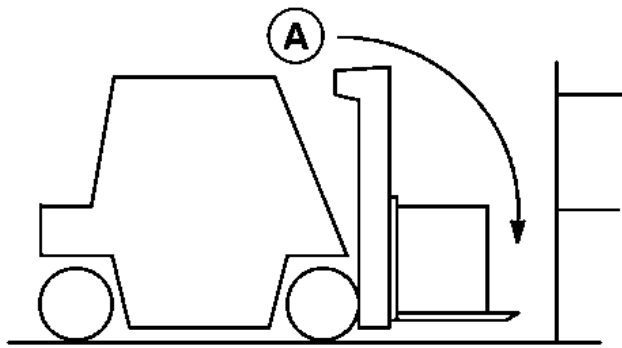

A. BE CAREFUL OF FORKS BEYOND THE LOAD

If the forks are longer than the load, move the forks under the load so that the tips of the forks do not extend beyond the load. Lift the load from the surface. Move backward a few inches, then lower the load onto the surface and inch forward to engage the load against the carriage. Tilt the mast backward just far enough to lift the load from the surface.

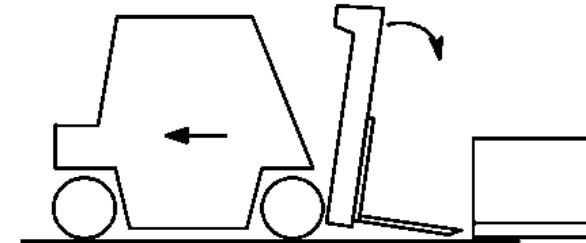

3. When a load is put on the floor, tilt the mast forward to a vertical position and lower the load. Tilt the mast forward to permit smooth removal of the forks. Carefully move the lift truck backward to remove the forks from under the load.

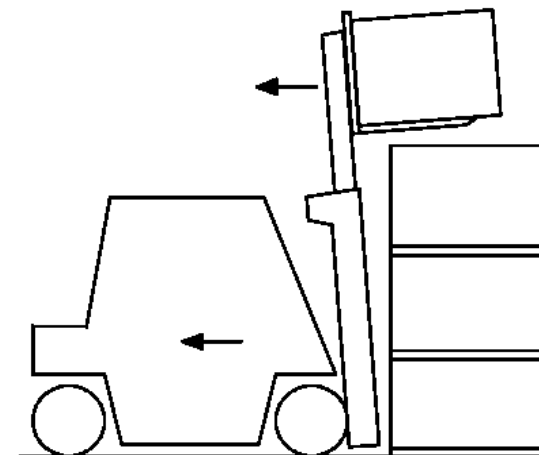

4. If the load is being removed from a stack, slowly move the lift truck away from the stack. When the load is clear of the stack, lower the load for traveling. Always travel with

HYSTER

Operating Procedures

the load as low as possible and tilted backward. Lowering speed is controlled by the position of the control lever. Lower slowly and smoothly. Slowly return the control lever to the neutral position so that the load is not dropped or that the lift truck is not tipped over due to the rapid stop of the load.

WARNING

Move carefully and smoothly when the load is raised over a stack. When the load is elevated the center of gravity of the lift truck and the load is much higher. The lift truck can tip over when the load is raised and cause serious injury to personnel and damage to the lift truck and materials.

5. To put the load on a stack, align the lift truck with the stack. Raise the load higher than the point where it will be placed. Do not raise the load to a point below where the load is to be placed and "jog" the load up into position. This operation uses added energy. Be careful not to damage or move adjacent loads.

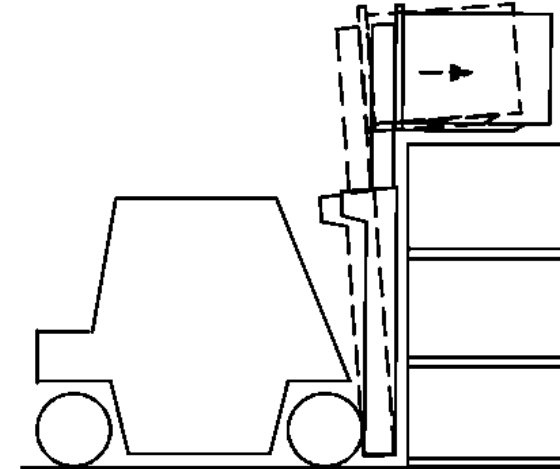

WARNING

IF THE LIFT TRUCK TIPS OVER EITHER TO THE SIDE OR FORWARD, DO NOT JUMP OFF! HOLD FIRMLY TO STEERING WHEEL, BRACE YOUR FEET, AND LEAN FORWARD AND AWAY FROM THE POINT OF IMPACT.

If the above steps are not followed during a lift truck tipover, injury to personnel can occur.

Operating Procedures

HYSTER

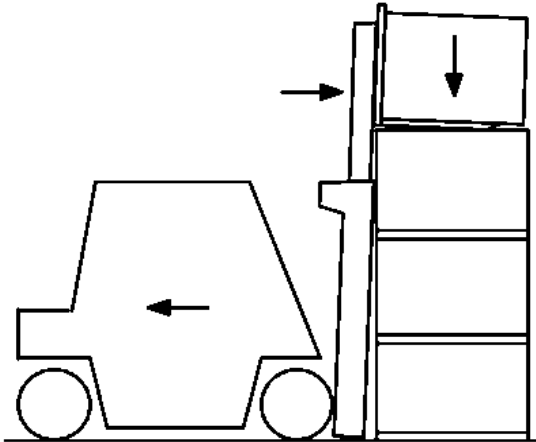

Move forward slowly. When the load is in position, lower the load on to the stack or the rack. Lower the forks just enough to remove them from under the load. Do not lower the forks so that they will drag on the surface under the load. Tilt the mast forward just enough to permit smooth removal of the forks from under the load. Carefully move the lift truck backward to remove the forks from under the load. Lower the forks when traveling.

NOTE: Not every load can be lifted using only the forks of a lift truck. Some loads will require a special attachment.

6. When lifting round objects, use a block behind the object. Tilt the mast forward so that the forks can slide

along the floor under the object to be lifted. Tilt the mast fully backward to help keep the load on the forks.

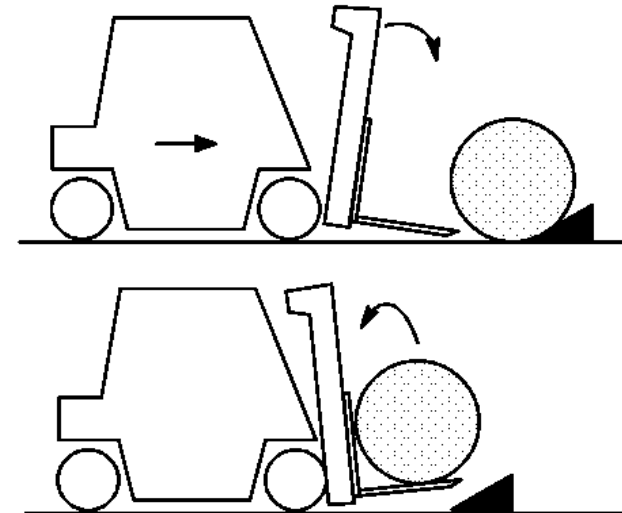

Load Handling, Traveling

1. When traveling with the load lowered, keep the load against the carriage and the mast tilted fully backward. This action will help keep the load on the forks and provide good forward and side stability.



HYSTER

Operating Procedures

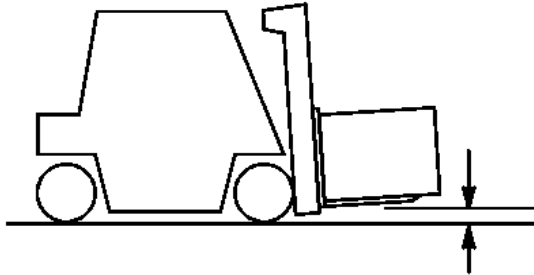

2. Travel with the lift mechanism raised only enough to clear the ground or obstacles.

When the mast, carriage, or load is in a raised position, the stability of the lift truck is reduced. This is also critical when the lift truck is not carrying a load. The ability of the lift truck to resist side tipping can be less on a lift truck without a load than it is on a lift truck with a load in the lowered (travel) position. Therefore, a lift truck without a load is more likely to tip sideways, especially in a turn, than a lift truck with a load carried in the lowered position.

WARNING

Some lift trucks have mirrors for viewing along the side to observe the tail swing area. These mirrors are an aid to the driver, but are **NOT** driving mirrors and must **NOT** be used as such when operating in reverse.

Always look in the direction of travel to avoid damage to something or injury to someone.

3. For better visibility with large loads, travel with the load trailing, but always keep a proper lookout in the direction of travel. Normally, direction of travel is determined by the best visibility available to the operator. If the lift truck must travel in a direction where visibility is obstructed, a lookout helper is required. Never drive when visibility is obstructed.

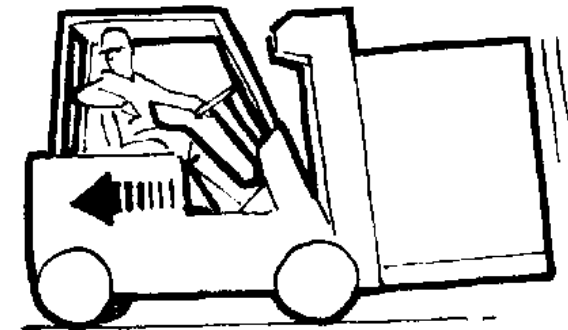

4. When traveling up or down grades in excess of 5% with a **heavily loaded** lift truck, keep the load upgrade to maintain control.

Operating Procedures

HYSTER

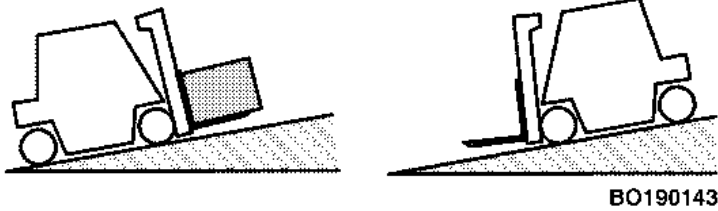

When operating an **unloaded** lift truck on a grade in excess of 5%, keep the counterweight up grade.

5. Watch out for pedestrians at all times. Do not drive up to anyone standing in front of an object. Use extra care at cross-aisles, doorways, and other locations where pedestrians can step into the path of travel of the lift truck.



BO190144

Slow down when approaching blind intersections or turns and sound the horn. The horn is to warn pedestrians that there is a vehicle in the area and to be alert to possible danger.

6. Anytime the lift truck is moving keep arms, legs, etc., inside the operator's compartment. Arms and legs outside the machine can be injured when passing obstructions.

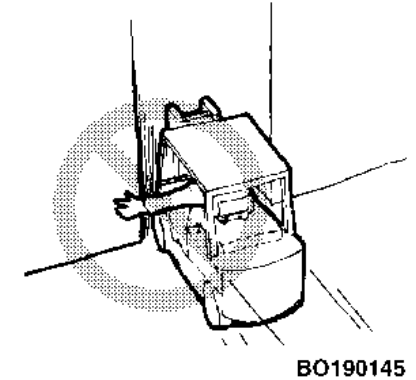

7. Avoid bumps, holes, mud, slick spots, and loose materials that may cause the lift truck to swerve or tip. If unavoidable, slow down.

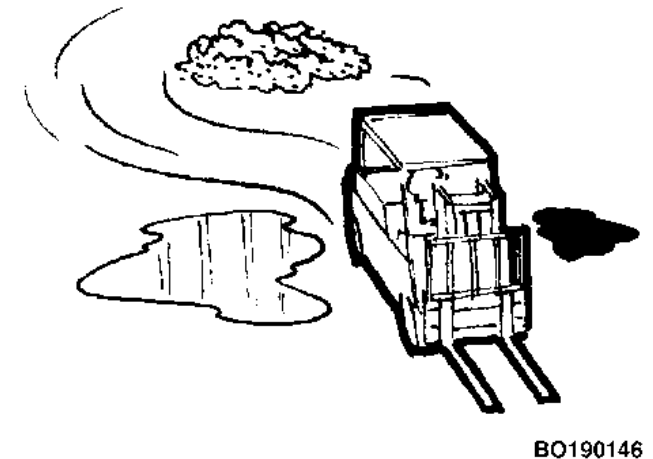

Different models of lift trucks are designed to operate under different conditions. Solid rubber tire models are designed to operate on relatively smooth, firm surfaces. Lift trucks with pneumatic tires can adapt to more uneven ground. Always make sure you pick the smoothest route for your lift truck.



HYSTER

Operating Procedures

8. Watch clearances, especially forks, mast, overhead guard, and tail swing. A lift truck is designed to perform a wide variety of functions within limited space.

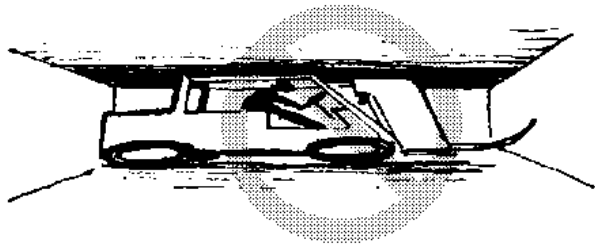

BO190147

The operator must be aware that the forks can sometimes extend beyond the front of the load. If the forks extend beyond the load, the operator can hit an object or lift another load. Serious accidents can be caused by mast and overhead guards hitting pipes and beams near the ceiling.

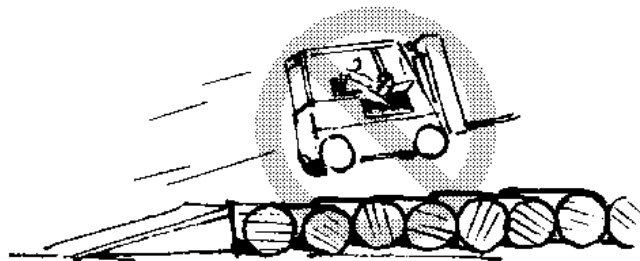

BO190148

9. Do not indulge in stunt driving or horseplay.

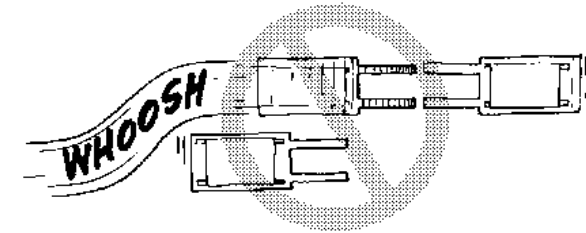

BO190149

10. Do not pass another lift truck traveling in the same direction at intersections, blind spots, or at other dangerous locations.

11. Stay away from the edge of the road. Keep the wheels of the lift truck on the roadway. If the wheels are allowed to run off the edge of the travel surface onto soft ground, the lift truck can tip over.

12. Under all travel conditions, operate the lift truck at a speed that will permit it to be brought to a stop in a safe manner.

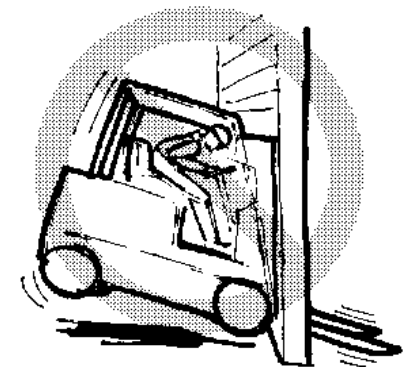

BO190150



Operating Procedures

HYSTER

Load Handling, Emergency Load Lowering

 **WARNING**

When the electronic signal to the mini-levers is disrupted, the mast assembly can **ONLY** be lowered with the emergency load lowering valve, located on the main hydraulic valve (see Figure 27). When using the emergency load lowering valve to lower a load, serious injury can result if anyone is near the load or under the load.

 **WARNING**

Always lower the mast assembly when leaving the lift truck unattended.

NOTE: The emergency load lowering valve is to be used **ONLY** if the electrical signal to the main control valve has been disrupted and there is a load lifted.

To use the emergency load lowering valve, follow these steps:

1. Remove floor mat and floor plate.
2. Turn the emergency load lowering valve two complete turns to the left. See **Figure 27**.
3. When load has been lowered, close the emergency load lowering valve.
4. Install floor plate and floor mat.

HYSTER

Operating Procedures

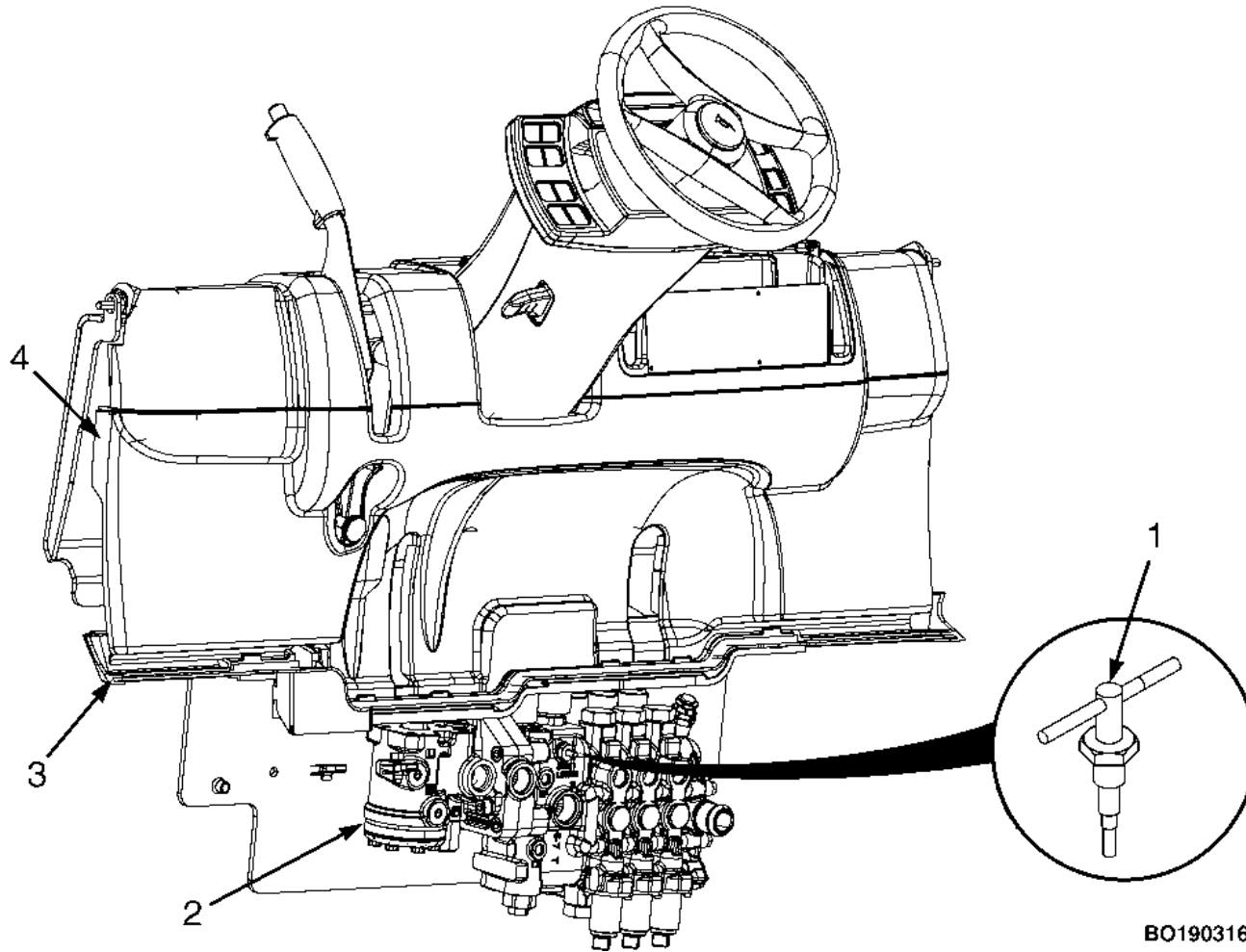

1. EMERGENCY LOAD LOWERING VALVE
2. MAIN CONTROL VALVE
3. COWL WELDMENT
4. KICK PANEL

Figure 27. Emergency Load Lowering Valve

Operating Procedures

HYSTER

Highway Trucks, Rail Cars, and Docks

⚠ WARNING

Maintain a safe distance from the edge of docks, ramps, platforms and other similar working surfaces. Watch the “tail swing.” Remember when traveling in the forward direction and the steering wheel is turned to move the lift truck away from the edge of the dock, the rear will swing toward the edge. This action can cause the lift truck to fall off the dock.

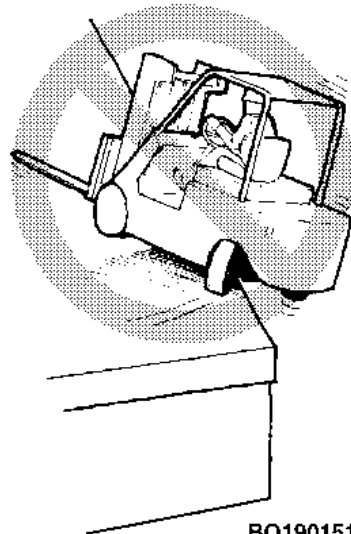

BO190151

IF THE LIFT TRUCK FALLS OFF THE DOCK, DO NOT JUMP OFF! HOLD FIRMLY TO STEERING WHEEL, BRACE YOUR FEET, AND LEAN FORWARD AND AWAY FROM THE POINT OF IMPACT.

If the above steps are not followed during a lift truck tipover, injury to personnel can occur.

Before operating in a highway truck or rail car, observe the following:

- DO NOT use a lift truck to move a rail car.

- DO NOT use a lift truck to open or close the door on a rail car unless the lift truck has an attachment that is specifically designed for opening and closing rail car doors and the operator is trained in its use.

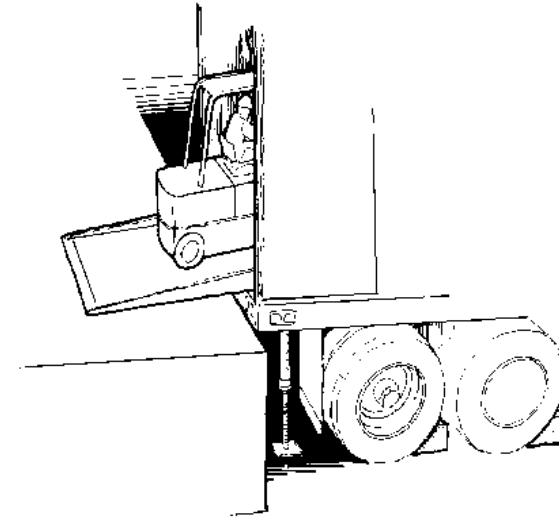

BO190152

- Check to make sure that the brakes on the highway truck are set and that wheel blocks have been placed on both sides of the rear wheels (unless a dock locking mechanism is engaged). Fixed jacks may be necessary to support the front and rear of a highway truck trailer to prevent it from moving or tipping during loading or unloading.



HYSTER

Operating Procedures

- Make sure that the rail car brakes are set and the wheels are blocked while loading or unloading. Do this check so that the rail car will not move due to the movement of the lift truck in and out of the rail car.
- Check the condition of the driving surface. Make sure the floor will support the weight of the lift truck and the load.
- Make sure the dock board is secured, in good condition, and of the proper capacity.
- When entering a rail car, the operator can enter at an angle (if the dock plate or bridge is wide enough). This will reduce the turning required after entering.
- Never leave a parked truck on a dock plate.

Attachments



BO190153

NOTE: Make sure the Nameplate is correct if an attachment has been installed.

If an attachment is installed on the lift truck, make sure the operating instructions are available and understood before operating the attachment. For the operation of attachment control levers, see **Table 3**, **Figure 22**, and **Figure 28**.

Attachments must be removed or installed by trained personnel only.

Disconnecting Attachment Hydraulic Quick-Disconnect Hoses

NOTE: **Step 1** through **Step 4** is to be used for lift trucks equipped with electro-hydraulics.

1. Turn the key switch or keyless switch to the **OFF** position.
2. Disconnect the negative terminal of the battery.

NOTE: If the Quick-Disconnect hose connectors cannot be disconnected, repeat **Step 3** and **Step 4**. If the hoses still cannot be disconnected, notify service personnel.

3. Press the plunger button located on the top of the pressure relief valve, and listen for the flow of hydraulic fluid through the valve when the button is pressed. See **Figure 28**.

Operating Procedures

HYSTER

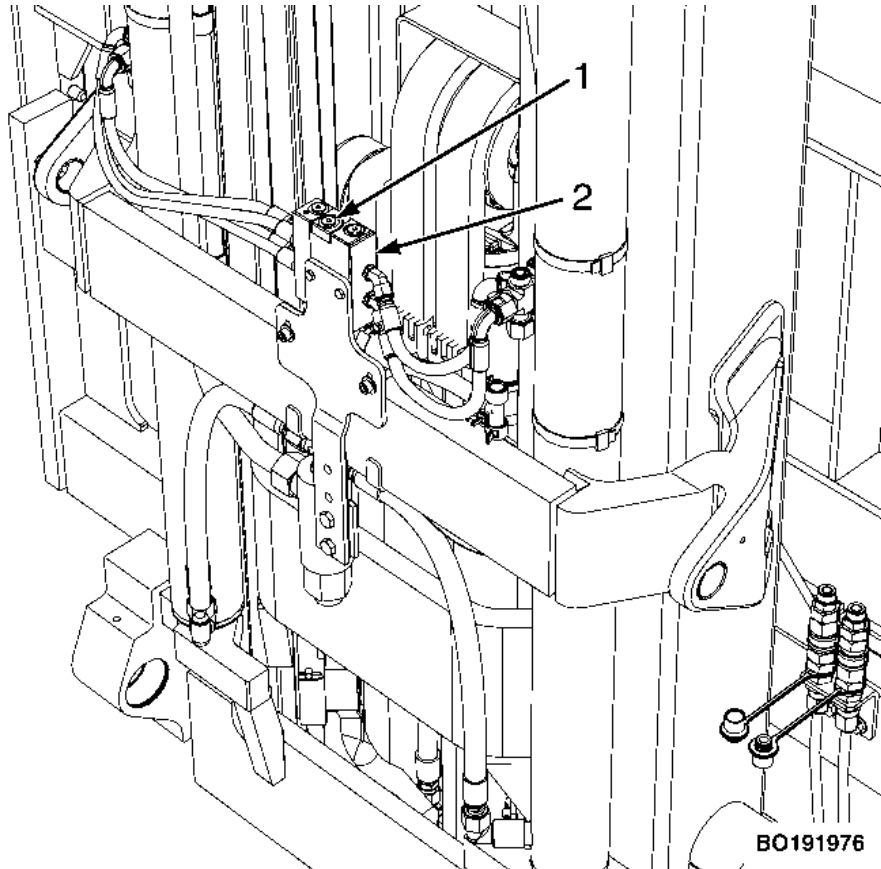

1. PLUNGER BUTTON
2. PRESSURE RELIEF VALVE

Figure 28. Quick-Disconnect Procedure

4. Disconnect the Quick-Disconnect hose connectors.

NOTE: Step 5 through Step 7 is to be used for lift trucks equipped with manual hydraulics.

5. Turn the key switch or keyless switch to the **OFF** position.

6. Disconnect the negative terminal of the battery.

7. Move the manual hydraulic levers forward and backward to relieve the system hydraulic pressure.

8. Disconnect the Quick-Disconnect hose connectors.

Connecting Attachment Hydraulic Quick-Disconnect Hoses

NOTE: Step 1 through Step 4 is to be used for lift trucks equipped with manual hydraulics.

1. Connect the Quick-Disconnect hose connectors.

2. Connect the negative terminal of the battery.

3. Turn the key switch or keyless switch to the **ON** position and start the engine.

4. Move the manual hydraulic levers forward and backward, and check the hydraulic system for leaks.



HYSTER

Operating Procedures

NOTE: Step 5 through Step 8 is to be used for lift trucks equipped with electro-hydraulics.

5. Connect the Quick-Disconnect hose connectors.
6. Connect the negative terminal of the battery.
7. Turn the key switch or keyless switch to the **ON** position and start the engine.
8. Move the mini-levers forward and backward, and check the hydraulic system for leaks.

Stopping

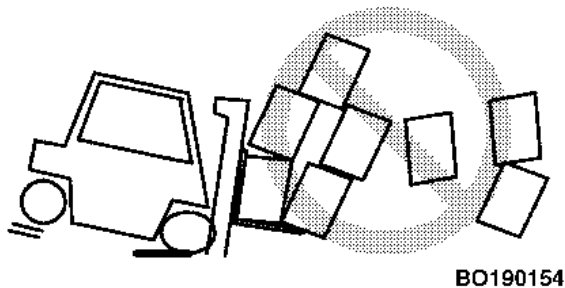

Stop the lift truck as gradually as possible. Hard braking and wheel sliding can cause the forklift to tip or the load to fall off of the forks and damage the load or hurt someone.

Parking

The operator must never leave a lift truck in a condition so that it can cause damage and injury. When parking the lift truck, do the following operations:

1. Stop the lift truck and apply the parking brake. Applying the parking brake puts the transmission in **NEUTRAL** when the lift truck has a MONOTROL® pedal.
2. Fully lower the forks or carriage. Tilt mast forward until the tips of the forks touch the ground.
3. If equipped, move the Direction Control Lever to the **NEUTRAL** position.



CAUTION

For Kubota diesel engines only - allow engine to idle for 5 minutes before shutting it OFF after full load operation. Failure to do so may result in turbo charger damage.

4. Turn the key to the **OFF** position to stop the engine.
5. If the lift truck must be left on an incline, put blocks on the down hill side of the wheels so that the lift truck can not move.



Operating Procedures

HYSTER

6. Check engine compartment, if operating in areas containing combustible material, and remove foreign debris. See **FIRE HAZARD WARNING** at the beginning of this section.

7. If the lift truck is equipped with an LPG fuel system and the lift truck is not in active use, close the fuel valve at the

tank. If the lift truck is going to be left over night or longer, the truck must be parked outside or the LPG tank must be removed and stored outside.

Do not park the lift truck so that it limits access to fire aisles, stairways, and fire equipment.



HYSTER

Maintenance

Maintenance

General

WARNING

Do not make modifications to the lift truck that affect the safe operation of the lift truck. Don't add parts or components that affect visibility.

Do not make repairs or adjustments unless you have both authorization and training. Repairs and adjustments that are not correct can make a dangerous operating condition and cause injury to personnel.

Do not operate a lift truck that needs repairs. Report the need for repairs immediately. If repair is necessary, put a "DO NOT OPERATE" tag in the operator's area. If truck is equipped with a key switch, remove the key.

CAUTION

Disposal of lubricants and fluids must meet local environmental regulations.

This section contains a **Maintenance Schedule** and the instructions for maintenance and inspection.

The **Maintenance Schedule** has time intervals for inspection, lubrication, and maintenance for your lift truck. The service intervals are provided in both operating hours recorded on the lift truck hour meter, and in calendar time. Use the interval that occurs first.

The recommendation for the time intervals are for eight hours of operation per day. The time intervals must be decreased from the recommendations in the **Maintenance Schedule** for the following conditions:

- If the lift truck is used more than eight hours per day.
- If the lift truck must work in dirty operating conditions.
- Poor ground conditions.
- Intensive usage at high performance levels or other abnormal conditions will require more frequent servicing.

Your dealer for **Hyster** lift trucks has the equipment and trained service personnel to do a complete program of inspection, lubrication, and maintenance. A regular program of inspection, lubrication, and maintenance will help your lift truck provide more efficient performance and operate for a longer period of time.



Maintenance

HYSTER

Some users have service personnel and equipment to do the inspection, lubrication, and maintenance shown in the **Maintenance Schedule**. **Service Manuals** are available from your dealer for **Hyster** lift trucks to help users who do their own maintenance.

Serial Number Data

The serial number for the lift truck is on the Nameplate. It is also on the right side of the frame, under the floor plate.

How to Move a Disabled Lift Truck

WARNING

Use extra caution when towing a lift truck if any of the following conditions exist:

1. Brakes do not operate correctly.
2. Steering does not operate correctly.
3. Tires are damaged.
4. Traction conditions are bad.
5. The lift truck must be towed on a slope.

If the engine cannot run, there is no power available for the hydraulic steering system. This condition can

make the lift truck difficult to steer. Poor traction can cause the disabled lift truck or towing vehicle to slide. A slope will also make the lift truck more difficult to stop.

Never lift and move a disabled lift truck unless the disabled lift truck **MUST** be moved and cannot be towed. A lift truck used to move a disabled lift truck **MUST** have a capacity rating equal to or greater than the weight of the disabled lift truck. The capacity of the lift truck used to move a disabled lift truck must have a load center equal to half the width of the disabled lift truck. See the Nameplate of the disabled lift truck for the approximate total weight. The forks must extend the full width of the disabled lift truck. Put the weight center of the disabled lift truck on load center of the forks. Be careful to not damage the under side of the lift truck.

How to Tow the Lift Truck

CAUTION

To prevent damage to the transmission during towing, lift drive wheels off of ground or disconnect the drive-shaft.

HYSTER

Maintenance

CAUTION

DO NOT try to start the engine by pushing or towing the lift truck. Damage to the transmission can occur if engine is started by pushing or towing lift truck.

1. The towed lift truck must have an operator.
2. Tow the lift truck slowly.
3. Using a lift truck or a lifting device that can be attached to the mast (I.E. come-a-long), raise the carriage and forks approximately 30 cm (12 in.) from surface. Install a chain around a mast crossmember and the carriage, to prevent carriage and mast channels from moving.
4. If another lift truck is used to tow the disabled lift truck, that lift truck must have an equal or larger capacity than the disabled lift truck. Install approximately 1/2 of a capacity load on the forks of the lift truck that is being used to tow the disabled lift truck. This 1/2 capacity load will increase the traction of the lift truck. Keep the load as low as possible.
5. Use a towing link made of steel that fastens to the tow pins in the counterweights of both lift trucks. Slowly and carefully remove the slack out of the towing pin. See **Figure 29**.

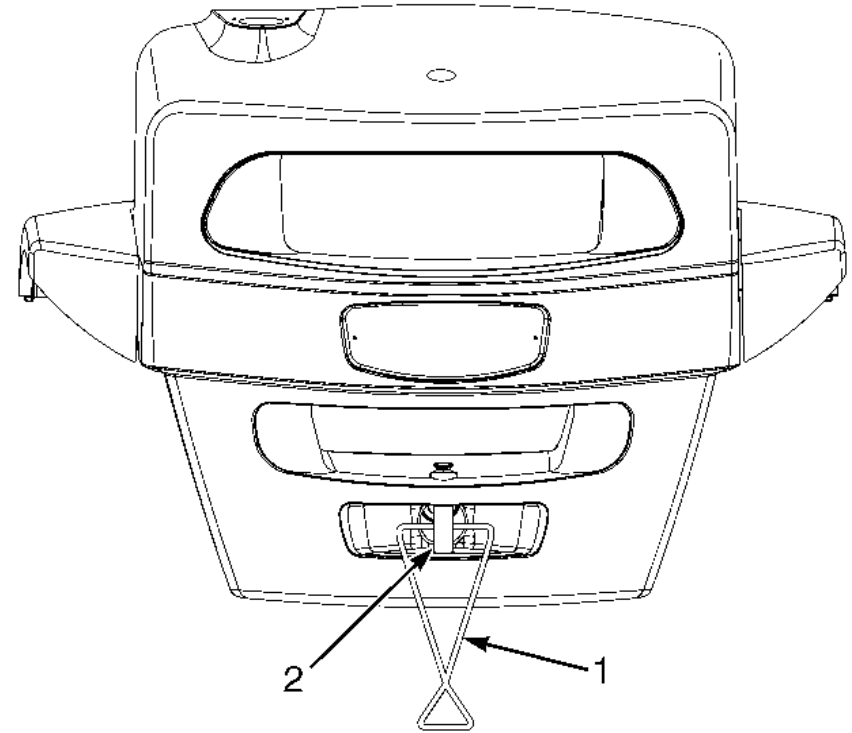

BO190317

1. STEEL TOW LINK
2. TOW PIN

Figure 29. Towing Lift Truck



Maintenance

HYSTER

How to Put a Lift Truck on Blocks

WARNING

The lift truck must be put on blocks for some types of maintenance and repair. The removal of the following assemblies will cause large changes in the center of gravity: mast, drive axle, engine and transmission, and the counterweight. When the lift truck is put on blocks, put additional blocks in the following positions to maintain stability:

1. Before removing the mast and drive axle, put blocks under the counterweight so that the lift truck cannot fall backward.
2. Before removing the counterweight, put blocks under the mast assembly so that the lift truck cannot fall forward.

The surface must be solid, even, and level when the lift truck is put on blocks. Make sure that any blocks used to support the lift truck are solid, one piece units.

NOTE: Some lift trucks have lifting eyes. These lifting eyes can be used to raise the lift truck so that blocks can be installed.

How to Raise the Drive Tires (See Figure 30)

1. Put blocks on each side (front and back) of the steering tires to prevent movement of the lift truck.
2. Put the mast in a vertical position. Put a block under each outer mast channel.
3. Tilt the mast fully forward until the drive tires are raised from the surface.
4. Put additional blocks under the frame behind the drive tires.
5. If the hydraulic system will not operate, use a hydraulic jack under the side of the frame near the front. Make sure that the jack has a capacity equal to at least half the weight of the lift truck. See the Nameplate.

How to Raise the Steering Tires (See Figure 30)

1. Apply the parking brake. Put blocks on both sides (front and back) of the drive tires to prevent movement of the lift truck.

HYSTER

Maintenance

2. Use a hydraulic jack to raise the steering tires. Make sure that the jack has a capacity of at least 2/3 of the total weight of the lift truck as shown on the Nameplate.

3. Put the jack under the steering axle or frame to raise the lift truck. Put blocks under the frame to support the lift truck.

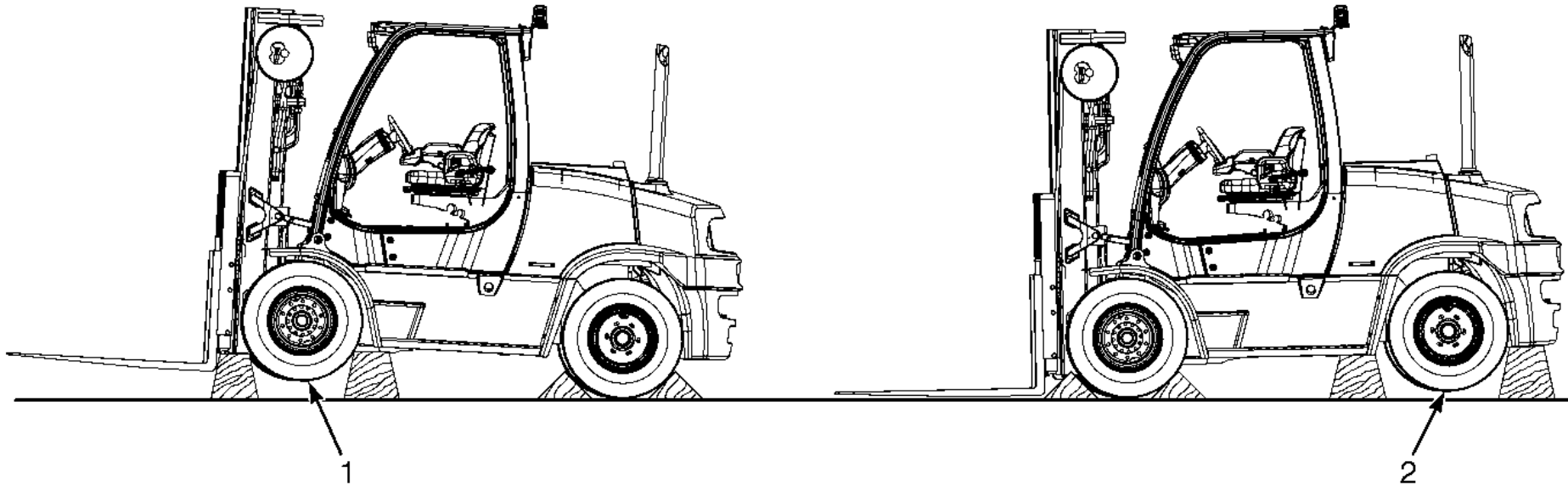

1. DRIVE TIRES

2. STEERING TIRES

BO190318

Figure 30. Put a Lift Truck on Blocks



Maintenance Schedule

HYSTER

How to Clean a Lift Truck



CAUTION

Your lift truck may be damaged if water or cleaning agents come in contact with electrical components. **DO NOT** directly spray any electrical components, especially connectors, switches, electro-hydraulic controls,

battery area, and dash display during the cleaning process.

Portions of your lift truck may be washed with a non-heated pressure washer. Steam cleaning is not recommended in most instances, as condensation may form in electrical components causing damage or erratic behavior. For cleaning guidelines and components to avoid, see the **Periodic Maintenance** section of the **Service Manual** for your lift truck.

HYSTER

Maintenance Schedule

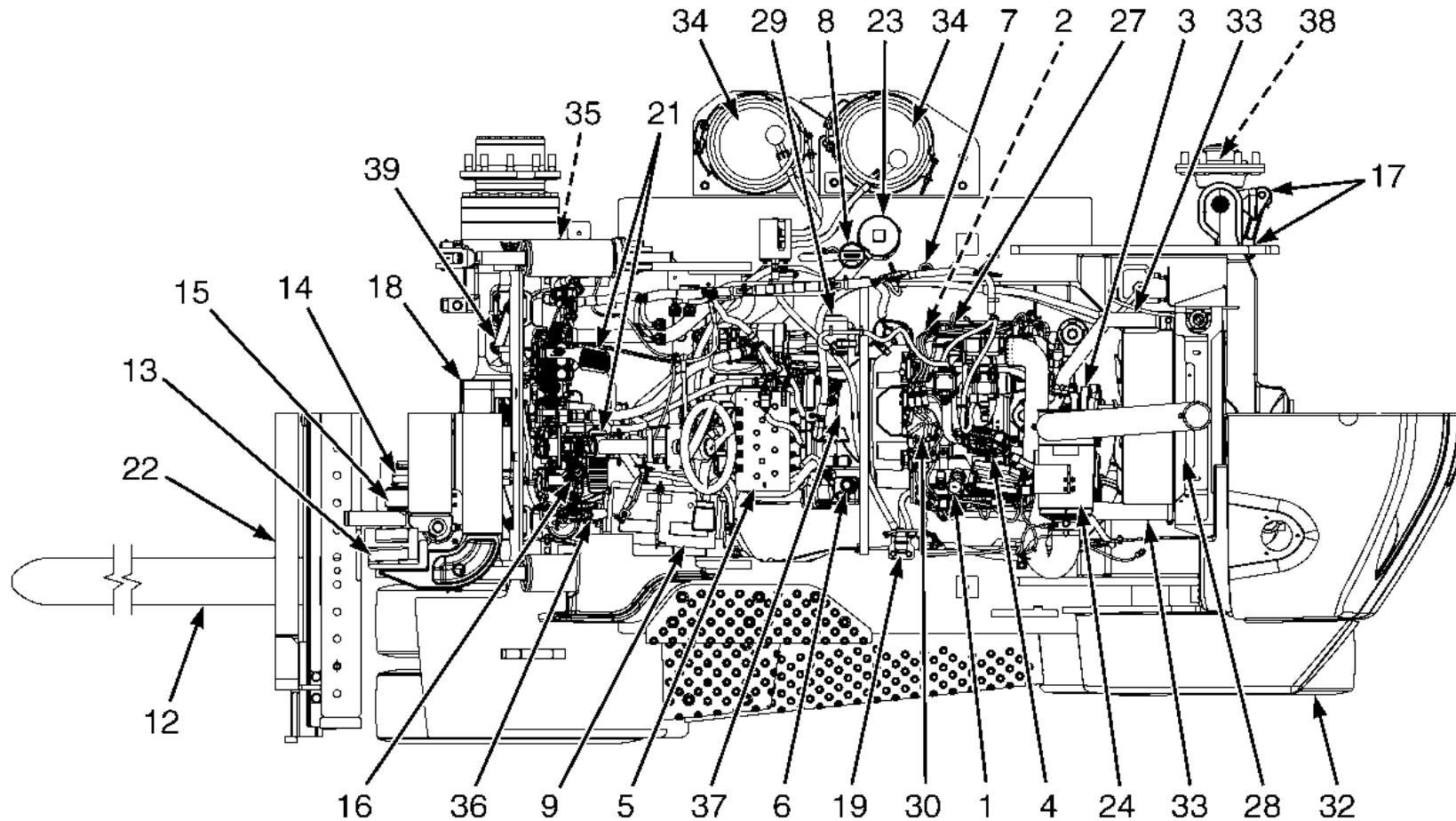

BO191511

Figure 31. Maintenance and Lubrication Points, 4.3L LPG Trucks

Maintenance Schedule

HYSTER

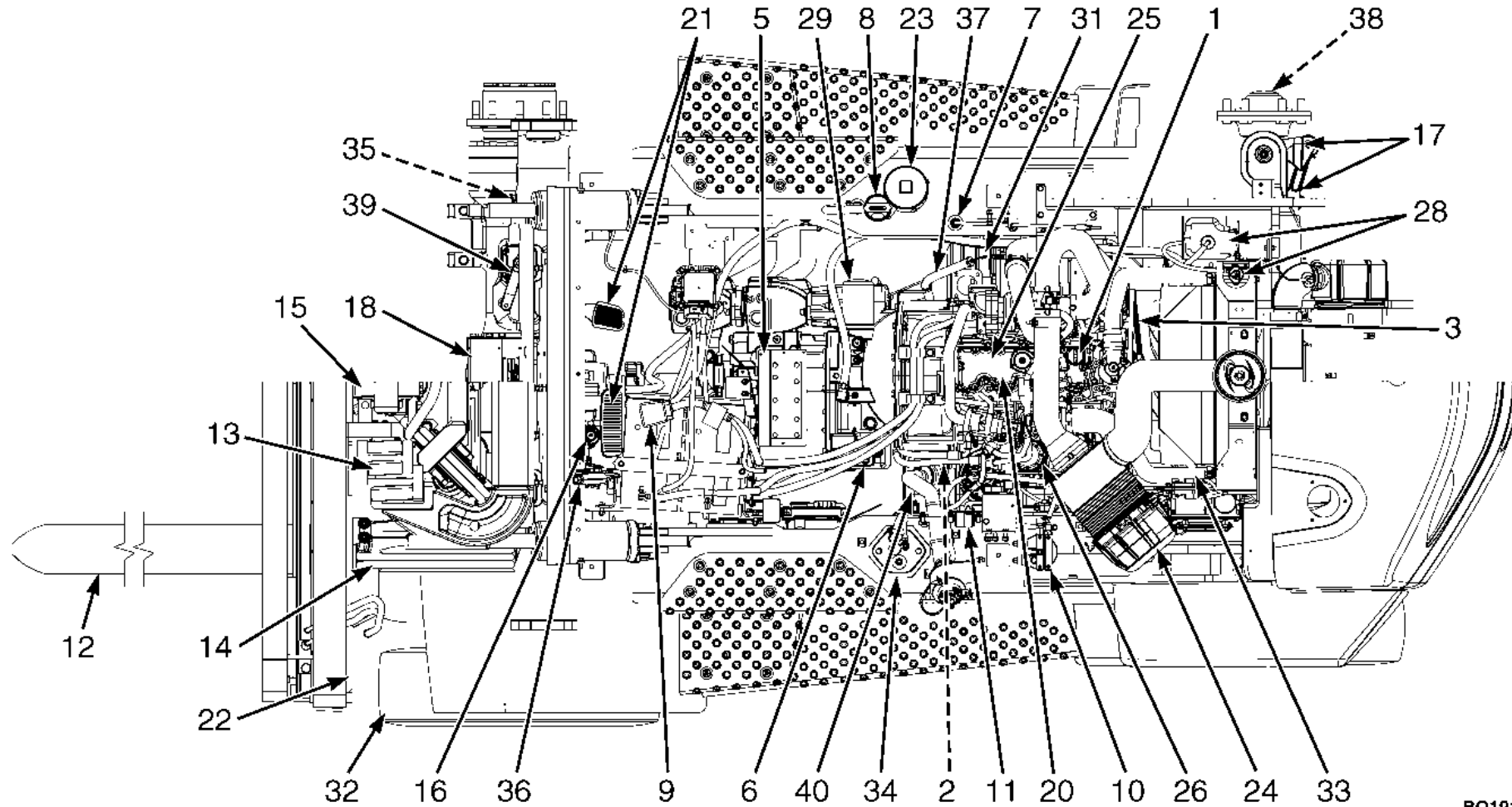

BO191509

Figure 32. Maintenance and Lubrication Points, Kubota 3.8L T4 Final Diesel Trucks

HYSTER

Maintenance Schedule

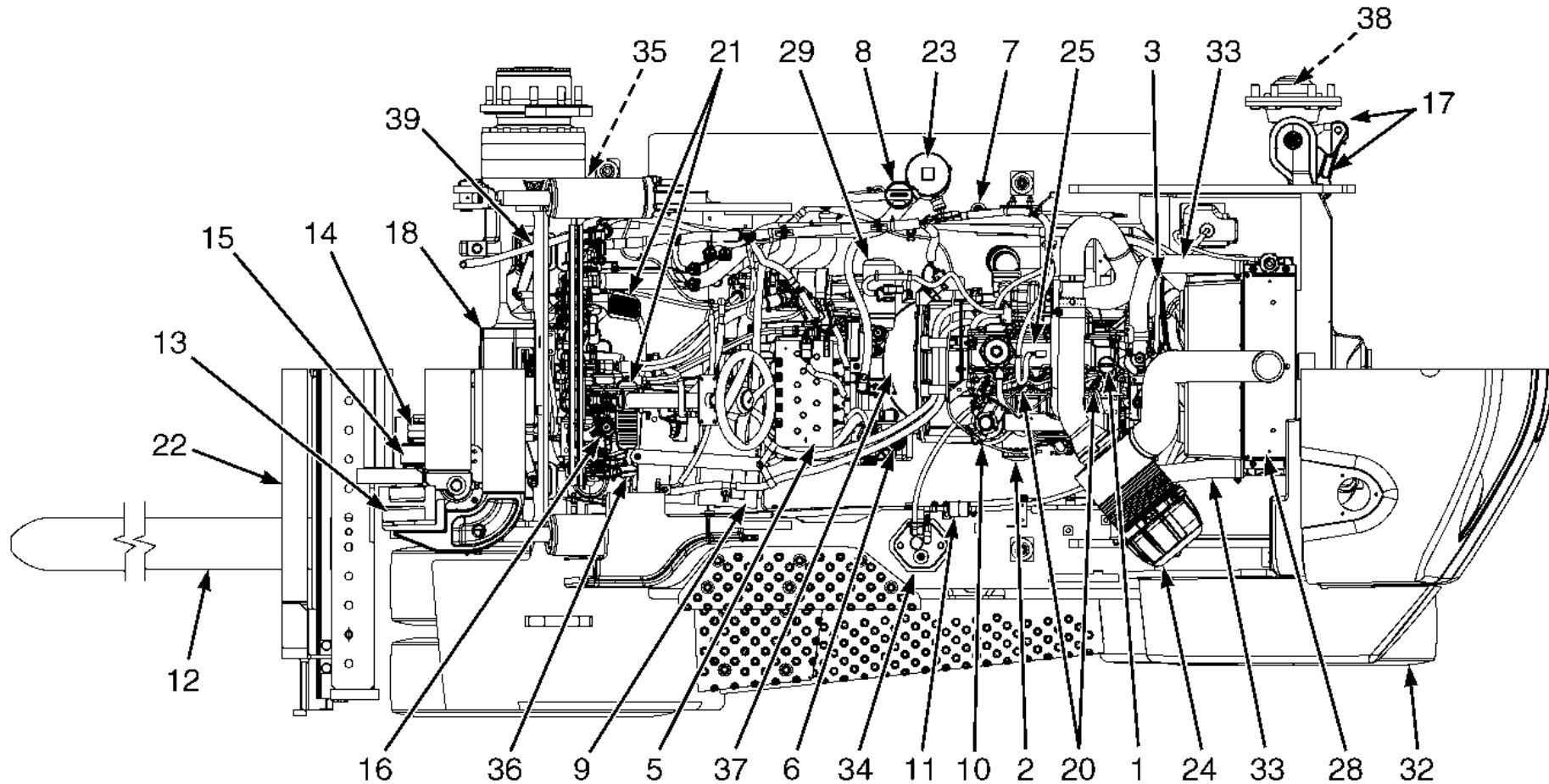

BO191510

Figure 33. Maintenance and Lubrication Points, Kubota 3.6L Diesel Trucks

Maintenance Schedule

HYSTER

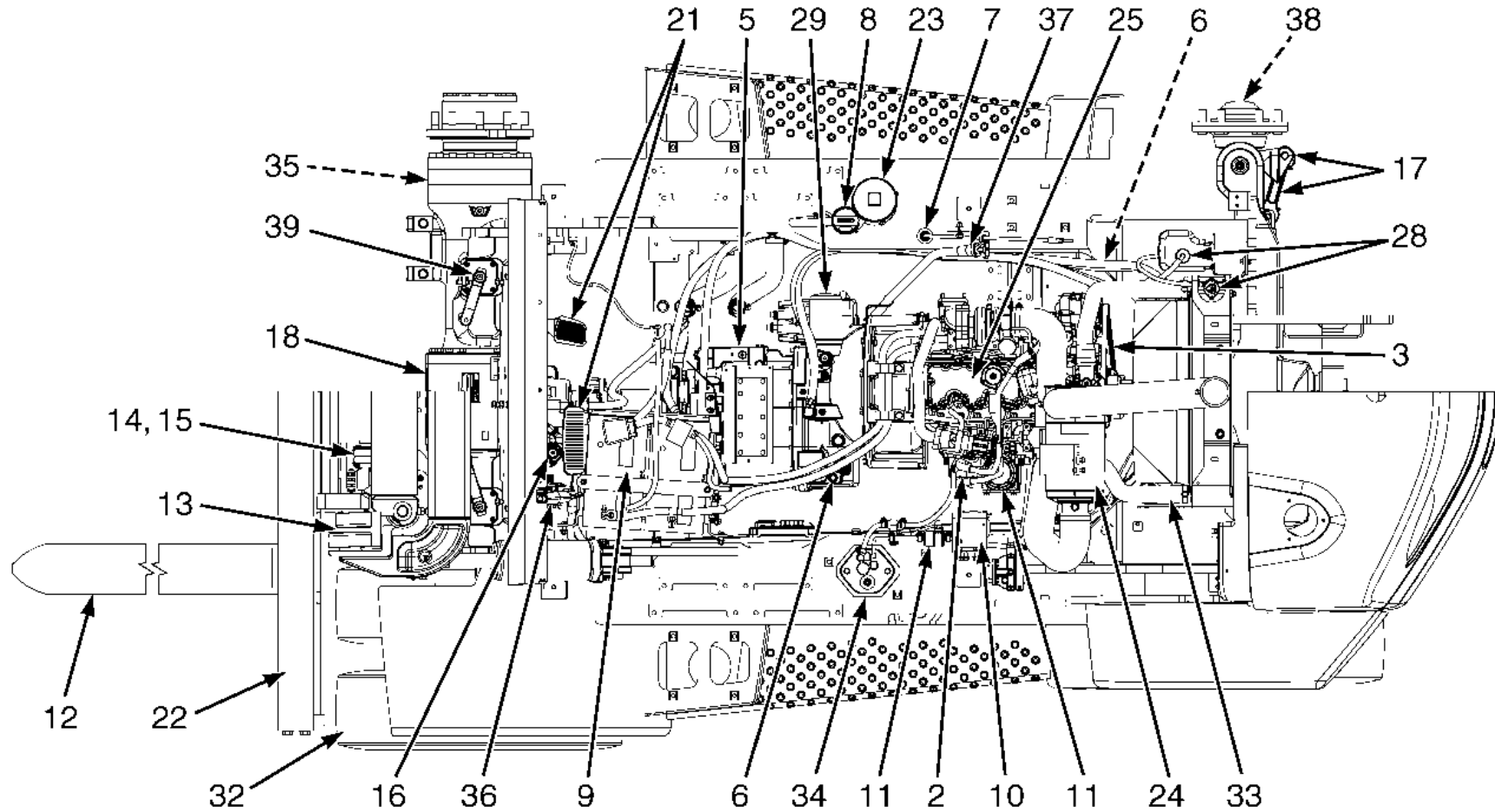

BO191614

Figure 34. Maintenance and Lubrication Points, Kubota 3.8L 55kW Diesel Trucks



HYSTER

Maintenance Schedule

Maintenance Schedule

(See Figure 31, Figure 32, Figure 33, and Figure 34)

Item No.	Item	8 Hr/ 1 Day	500 Hr/ 1 Yr	1000 Hr/ 1 Yr	2000 Hr/ 1 Yr	4000 Hr/ 2 Yr	Procedure or Quantity	Specification
32	TIRES AND WHEELS	X					Check Condition.	See Nameplate.
	SAFETY LABELS	X					Replace as Neces- sary.	See Parts Manual .
13, 14, 15, 22	MAST, CARRIAGE, HEADER HOSES, LIFT CHAINS, AND ATTACHMENT	X					Check Condition and Lubrication.	See Parts Manual .
	SEAT BELT, HIP RESTRAINTS, AND SEAT RAILS	X					Check Condition and Operation.	
	ENGINE COMPARTMENT	X					Remove Combustible Materials. See NOTE 5.	

X=Check C=Change L=Lubricate CIL=Check Indicator Light during operation



Maintenance Schedule

HYSTER

Item No.	Item	8 Hr/ 1 Day	500 Hr/ 1 Yr	1000 Hr/ 1 Yr	2000 Hr/ 1 Yr	4000 Hr/ 2 Yr	Procedure or Quantity	Specification
	PAPER APPLICATION Engine Compartment; Truck Components; Exhaust Wraps; Radiator; Radiator Screen, if equipped; Belly Pan, if equipped	X					Check Condition. Clean as Required Replace as Required. See NOTE 8.	
	CHECK FOR LEAKS - FUEL, OIL, WATER	X					Check for Leaks. See NOTE 1.	
	HYDRAULIC HOSES	X					Check Condition.	See Parts Manual .
33	COOLANT HOSES	X					Check Condition.	See Parts Manual .
34	FUEL TANK - LPG 4.3L	CIL					<u>Dual Tanks</u> 67 liter (17.7 gal) or 87 liter (23 gal) <u>Single Tank</u> 43.5 liter (11.5 gal)	LPG - HD 5 or HD 10
34	FUEL TANK Kubota 3.8L Diesel Engines	CIL					79 liter (20.8 gal)	See Table 6 See NOTE 21

X=Check C=Change L=Lubricate CIL=Check Indicator Light during operation



HYSTER

Maintenance Schedule

Item No.	Item	8 Hr/ 1 Day	500 Hr/ 1 Yr	1000 Hr/ 1 Yr	2000 Hr/ 1 Yr	4000 Hr/ 2 Yr	Procedure or Quantity	Specification
34	FUEL TANK Kubota 3.6L Diesel Engines	CIL					79 liter (20.8 gal)	See Table 6
	HORN, LIGHTS, ALARMS, FUSES, AND RELAYS	X					Check Operation.	
35	SERVICE BRAKES	X					Check Operation.	
36	PARKING BRAKE	X					Check Operation.	
	STEERING CONTROLS AND STEERING COLUMN GAS CYLINDER	X					Check Operation and Condition.	
5	TRANSMISSION	X					Check for Leaks and Operation.	
6	TRANSMISSION OIL BREATHER/DIPSTICK		X				Check Oil Level.	John Deere JDM J20C See NOTE 19.
6	TRANSMISSION OIL BREATHER/DIPSTICK		X				Check Breather. 1 Breather.	See Parts Manual.
37	TRANSMISSION OIL			C			24 liter (25.4 qt)	John Deere JDM J20C See NOTE 19.

X=Check C=Change L=Lubricate CIL=Check Indicator Light during operation



Maintenance Schedule

HYSTER

Item No.	Item	8 Hr/ 1 Day	500 Hr/ 1 Yr	1000 Hr/ 1 Yr	2000 Hr/ 1 Yr	4000 Hr/ 2 Yr	Procedure or Quantity	Specification
29	TRANSMISSION OIL FILTER			C			1 Filter See NOTE 4.	See Parts Manual .
5	TRANSMISSION				X		Perform Automatic Clutch Calibration.	See Calibration Procedures 8000 SRM 1134 for Calibration Procedures.
7	HYDRAULIC OIL	X	X			C	71.5 liter (75.8 qt) See NOTE 2, NOTE 3, and NOTE 16.	ISO VG 46 Hydraulic Oil -15 °C (5 °F) and Above See NOTE 19.
23	HYDRAULIC OIL FILTER				C		1 Filter See NOTE 16.	See Parts Manual .
8	HYDRAULIC TANK BREATHER		X		C		Inspect and Replace as Required. See NOTE 5.	See Parts Manual .
9	BATTERY AND CABLE TERMINALS		X				Clean.	

X=Check C=Change L=Lubricate CIL=Check Indicator Light during operation



HYSTER

Maintenance Schedule

Item No.	Item	8 Hr/ 1 Day	500 Hr/ 1 Yr	1000 Hr/ 1 Yr	2000 Hr/ 1 Yr	4000 Hr/ 2 Yr	Procedure or Quantity	Specification
1	ENGINE OIL 4.3L LPG Engine	X CIL	C Every 6 mo				4.7 liter (5.0 qt) See NOTE 4 and NOTE 5.	-7 °C (20 °F) and Below SAE 5W-20 16 °C (60 °F) and Below SAE 5W-30 -18 °C (0 °F) and Above SAE 10W-30 API SM ILSAC GF4 SAE J2362
2	ENGINE OIL FILTER 4.3L Engine		C Every 6 mo				1 Filter See NOTE 4 and NOTE 5.	See Parts Manual .
1	ENGINE OIL Kubota Diesel Engine	X CIL	C				13.2 liter (13.9 qt) See NOTE 4 and NOTE 5.	See Table 6
2	ENGINE OIL FILTER Kubota 3.8L Diesel Engine		C				1 Filter See NOTE 4 and NOTE 5.	See Parts Manual .
2	ENGINE OIL FILTER Kubota 3.6L Diesel Engine		C				1 Filter See NOTE 4 and NOTE 5.	See Parts Manual .

X=Check C=Change L=Lubricate CIL=Check Indicator Light during operation



Maintenance Schedule

HYSTER

Item No.	Item	8 Hr/ 1 Day	500 Hr/ 1 Yr	1000 Hr/ 1 Yr	2000 Hr/ 1 Yr	4000 Hr/ 2 Yr	Procedure or Quantity	Specification
24	AIR FILTER	X CIL			C		1 Filter See NOTE 5, NOTE 6, and NOTE 11.	See Parts Manual .
	ENGINE OIL PRESSURE Kubota Diesel Engine	CIL					Check Oil Pres- sure.	Kubota Diesel Engine at Idle Speed 50 kPa (7 psi)
3	DRIVE BELT 4.3L Engine		X				Check for Wear and Damage. No Adjustment Needed. See NOTE 5.	
3	DRIVE BELT Kubota Diesel Engine		X				Check for Wear and Damage. Adjust as Needed. See NOTE 5.	
4	LPG CONVERTER 4.3L LPG Engine						Drain Tar. See NOTE 5.	
	INTAKE VALVES 4.3L LPG Engine		C				Clean Carbon Buildup	Use Sea Foam Spray. (Hyster P/N 4032507)

X=Check C=Change L=Lubricate CIL=Check Indicator Light during operation



HYSTER

Maintenance Schedule

Item No.	Item	8 Hr/ 1 Day	500 Hr/ 1 Yr	1000 Hr/ 1 Yr	2000 Hr/ 1 Yr	4000 Hr/ 2 Yr	Procedure or Quantity	Specification
	ENGINE IDLE SPEED 4.3L Engine (LPG)							750 ±25 RPM
	ENGINE GOVERNED SPEED 4.3L (LPG) (No Load)							2400 ±25 RPM
	ENGINE IDLE SPEED Hot Engine Kubota Diesel		X				Coolant Temperature Greater Than 15 °C (59 °F)	800 ±50 RPM
	ENGINE GOVERNED SPEED (No Load) Kubota 3.8L Diesel		X					2200 ±25 RPM
	ENGINE GOVERNED SPEED (No Load) Kubota 3.6L Diesel		X					2580 ±50 RPM
	OXYGEN SENSOR 4.3L Engine				X CIL		Replace as Neces- sary.	
25	VALVE ADJUSTMENT 4.3L Engine						Not Adjustable.	

X=Check C=Change L=Lubricate CIL=Check Indicator Light during operation



Maintenance Schedule

HYSTER

Item No.	Item	8 Hr/ 1 Day	500 Hr/ 1 Yr	1000 Hr/ 1 Yr	2000 Hr/ 1 Yr	4000 Hr/ 2 Yr	Procedure or Quantity	Specification
25	VALVE ADJUSTMENT Kubota Engine			X			Adjust as Required.	Intake 0.23 to 0.27 mm (0.009 to 0.011 in.) Exhaust 0.23 to 0.27 mm (0.009 to 0.011 in.)
19	LPG FUEL FILTER 4.3L Engine			C			1 Filter	See Parts Manual .
10	FUEL WATER SEPARATOR FILTER Kubota Diesel Engine	CIL	C				1 Filter Drain Water from Filter as Required.	See Parts Manual .
11	IN-LINE FUEL STRAINER Kubota Diesel Engine			C			1 Filter	See Parts Manual .
26	CRANKCASE BREATHER FILTER Kubota 3.8L Engine			C			1 Filter See NOTE 20.	See Parts Manual .
	OIL BREATHER Kubota 3.6L Engine				X		Check Condition.	
20	FUEL INJECTORS 4.3L LPG Engine				X		Check and Replace if Required. 6 Injectors	

X=Check C=Change L=Lubricate CIL=Check Indicator Light during operation



HYSTER

Maintenance Schedule

Item No.	Item	8 Hr/ 1 Day	500 Hr/ 1 Yr	1000 Hr/ 1 Yr	2000 Hr/ 1 Yr	4000 Hr/ 2 Yr	Procedure or Quantity	Specification
20	FUEL INJECTORS Kubota Diesel Engines				X		Check and Replace if Required. 4 Injectors	
27	SPARK PLUGS 4.3L Engines			C			Change Spark Plugs. 6 Plugs	1.5 mm (0.059 in.) AC41-993
28	COOLING SYSTEM 4.3L Engine	X CIL			C		15.1 liter (15.9 qt)	See NOTE 12.
28	COOLING SYSTEM Kubota Engine	X CIL			C		11 liter (11.6 qt)	See NOTE 13.
	CLEAN DEBRIS FROM RADIATOR CORE		X				See NOTE 5.	
12	FORKS	X	X		X		Check Condition.	
12	FORK LATCHES		L				Lubricate as Nec- essary.	Multipurpose Grease See NOTE 7.
	LIFT SYSTEM, OPERATE	X					Check Operation.	
13	MAST Sliding Surfaces and Load Roller Surfaces		L				Lubricate as Required. See NOTE 9.	Multipurpose Grease See NOTE 7.

X=Check C=Change L=Lubricate CIL=Check Indicator Light during operation



Maintenance Schedule

HYSTER

Item No.	Item	8 Hr/ 1 Day	500 Hr/ 1 Yr	1000 Hr/ 1 Yr	2000 Hr/ 1 Yr	4000 Hr/ 2 Yr	Procedure or Quantity	Specification
14	HEADER HOSES		X				Check Condition.	
15	LIFT CHAINS	X					Check Condition. Lubricate if neces- sary. See NOTE 10.	Engine Oil SAE 30W
15	LIFT CHAINS		L	L,X			Check for Wear. Lube as Required.	Engine Oil SAE 30W
	MAST Pivots		L				2 Fittings	Multipurpose Grease See NOTE 7.
22	MAST Hang On Sideshift Carriage Sliding Surfaces (Upper and Lower Bearings)	X	L	X			Lube as Required. 4 Fittings for Upper Bearings and 3 Lower Bearing Strips. Check Lower Bear- ing Strips for Wear.	Multipurpose Grease See NOTE 7 and NOTE 15. 2.5 mm (0.10 in.) Minimum Thickness.

X=Check C=Change L=Lubricate CIL=Check Indicator Light during operation



HYSTER

Maintenance Schedule

Item No.	Item	8 Hr/ 1 Day	500 Hr/ 1 Yr	1000 Hr/ 1 Yr	2000 Hr/ 1 Yr	4000 Hr/ 2 Yr	Procedure or Quantity	Specification
	Mast		X	X	X		Check/Adjust for Required Play	1 mm (0.04 in.) minimum - 2 mm (0.08 in.) maximum
	Bolzoni Hang On Sideshift Lower Hooks		X	X	X		Check Torque 8 Sockethead Screws	280 N•m (207 lbf ft)
	Mast		X	X	X		Check Torque 4 Sockethead Screws	50 N•m (37 lbf ft)
	Bolzoni Hang On Sideshift Side Rollers		X	X	X		Check Operation Check for Damage Replace as Necessary	See Parts Manual

X=Check C=Change L=Lubricate CIL=Check Indicator Light during operation



Maintenance Schedule

HYSTER

Item No.	Item	8 Hr/ 1 Day	500 Hr/ 1 Yr	1000 Hr/ 1 Yr	2000 Hr/ 1 Yr	4000 Hr/ 2 Yr	Procedure or Quantity	Specification
	Mast		L	L	L		Lube as Required 2 Fittings	Multipurpose Grease See NOTE 7
	Bolzoni Hang On Sideshift Upper Slide Blocks			X			Check Thickness Replace as Necessary	1.5 mm (0.05 in.) See Parts Manual
					C		Replace Slide Blocks	See Parts Manual
	MAST Fork Positioner	X	L	X			Lube as Required. 2 Fittings	Multipurpose Grease See NOTE 7 and NOTE 15.
	MAST Fork Positioner Cylinder Rod Anchors	X	L	X			Lube as Required. 2 Anchors	Multipurpose Grease See NOTE 7 and NOTE 15.
	MAST Fork Positioner and Lower Hook Capscrews		X				Check Torque. 8 Capscrews	See NOTE 15.
	MAST Fork Carrier			L			Lube as Required.	See NOTE 15.
	TILT CYLINDER ENDS		L				4 Fittings	Multipurpose Grease See NOTE 7.

X=Check C=Change L=Lubricate CIL=Check Indicator Light during operation



HYSTER

Maintenance Schedule

Item No.	Item	8 Hr/ 1 Day	500 Hr/ 1 Yr	1000 Hr/ 1 Yr	2000 Hr/ 1 Yr	4000 Hr/ 2 Yr	Procedure or Quantity	Specification
	BRAKE MASTER CYLINDER ROD END PIN		L					SAE 10W-30 API SM ILSAC GF4 SAE J2362
	MANUAL HYDRAULIC HAND LEVERS		L					SAE 10W-30 API SM ILSAC GF4 SAE J2362
16	BRAKE OIL Master Cylinder	CIL	X		C		0.35 liter (0.74 pt)	Dexron III from Sealed Container
	BRAKE SYSTEM ACCUMULATOR				X		Check Pre-charge Pressure.	Pre-charge Pressure 4 ±0.35 bar (58 ±5 psi)
17	STEERING AXLE Spindle Bearings			L			4 Fittings	Multipurpose Grease See NOTE 7.
17	STEERING AXLE Tie Rods		L				4 Fittings	Multipurpose Grease See NOTE 7.
38	WHEEL BEARINGS Steer Wheel				L		Check Grease.	Multipurpose Grease See NOTE 7.
21	PEDALS, LEVERS, SEAT RAILS, CABLES, HINGES, LINKAGES		L				Lubricate as Nec- essary.	Use Silicone Spray Hyster Part No. 328388.

X=Check C=Change L=Lubricate CIL=Check Indicator Light during operation



Maintenance Schedule

HYSTER

Item No.	Item	8 Hr/ 1 Day	500 Hr/ 1 Yr	1000 Hr/ 1 Yr	2000 Hr/ 1 Yr	4000 Hr/ 2 Yr	Procedure or Quantity	Specification
35	PARKING BRAKE ADJUSTMENT			X			Adjust as neces- sary.	Must Hold a Full Capacity Load on a 15% Grade.
35	PARKING BRAKE			L			Lubricate as Nec- essary.	Use Silicone Spray Hyster Part No. 328388.
18	DIFFERENTIAL AND DRIVE AXLE OIL (WET BRAKE)			C			Change Oil. Left/Right Chambers 15.6 liter (16.5 qt) Center Chamber 4.6 liter (4.9 qt)	Left/Right Chamber John Deere JDM J20C Center Chamber SAE J2360 Gear Oil.
18	DIFFERENTIAL AND DRIVE AXLE OIL (WET BRAKE)	X	X				Check for Leaks. Check Level.	
39	PARKING BRAKE LEVERS (WET BRAKE)			X			Check and Lubri- cate as Necessary	Normal operating environ- ment: Spray Lubricant Hyster P/N 4066494 Heavy-duty or contaminated environment: Multipurpose Grease See NOTE 7.
	INSPECT ENGINE ELECTRICAL SYSTEM, CONNECTORS			X				

X=Check C=Change L=Lubricate CIL=Check Indicator Light during operation



HYSTER

Maintenance Schedule

Item No.	Item	8 Hr/ 1 Day	500 Hr/ 1 Yr	1000 Hr/ 1 Yr	2000 Hr/ 1 Yr	4000 Hr/ 2 Yr	Procedure or Quantity	Specification
	INSPECT ENGINE VACUUM AND FUEL LINES AND FITTINGS				X			
	INSPECT LOCK-OFF FOR LEAKS AND ENSURE LOCK-OFF CLOSING				X			
	TEST LPG REGULATOR PRESSURE				X			
	CHECK AIR INDUCTION SYSTEM FOR LEAKS				X			
	CHECK MANIFOLD FOR VACUUM LEAKS				X			
	CHECK THROTTLE SHAFT FOR STICKING				X			
	CHECK INJECTORS AND RAILS FOR LEAKS				X			
	INSPECT EXHAUST MANIFOLD AND PIPING FOR LEAKS				X			
	INSPECT CATALYST INLET AND OUTLET				X			

X=Check C=Change L=Lubricate CIL=Check Indicator Light during operation



Maintenance Schedule

HYSTER

Item No.	Item	8 Hr/ 1 Day	500 Hr/ 1 Yr	1000 Hr/ 1 Yr	2000 Hr/ 1 Yr	4000 Hr/ 2 Yr	Procedure or Quantity	Specification
30	IGNITION SYSTEM: DISTRIBUTOR CAP, ROTOR, AND SPARK PLUG WIRES				C		Replace.	
	INSPECT MUFFLER INLET AND OUTLET				X		Replace as Required.	
31	Diesel Particulate Filter (DPF) Kubota Engine				X		Service.	See NOTE 14.
40	Diesel Exhaust Fluid (DEF) Filter Kubota Engine				C See NOTE 12.		Service Filter.	
40	Diesel Exhaust Fluid (DEF) Filter Kubota Engine	X					Check Levels.	32.5% Urea AUS 32 ISO 22241 Tank Capacity 20 liter (21.1 qt) Usable Fluid 15 liter (15.9 qt)
	Diesel Exhaust Fluid (DEF) Injector tip			X See NOTE 17.			Replace as Required.	See Parts Manual .

X=Check C=Change L=Lubricate CIL=Check Indicator Light during operation



HYSTER

Maintenance Schedule

Item No.	Item	8 Hr/ 1 Day	500 Hr/ 1 Yr	1000 Hr/ 1 Yr	2000 Hr/ 1 Yr	4000 Hr/ 2 Yr	Procedure or Quantity	Specification
	Diesel Exhaust Fluid (DEF) Pump Filter				C See NOTE 12.		Replace.	See Parts Manual .
	Diesel Exhaust Fluid (DEF) Tank Filter					C See NOTE 18.	Replace.	See Parts Manual .

X=Check C=Change L=Lubricate CIL=Check Indicator Light during operation



Maintenance Schedule

HYSTER

Item No.	Item	8 Hr/ 1 Day	500 Hr/ 1 Yr	1000 Hr/ 1 Yr	2000 Hr/ 1 Yr	4000 Hr/ 2 Yr	Procedure or Quantity	Specification
NOTE 1: Check fuel system for leaks prior to any service or maintenance activity.								
NOTE 2: Heavy-duty or high-temperature operations require more frequent checks.								
NOTE 3: Heavy-duty or contaminated applications will require hydraulic oil change at 2000 hours.								
NOTE 4: Change engine oil and filter after first 100 hours of operation. Change transmission oil filter after first 500 hours of operation.								
NOTE 5: Recommended service intervals are based on a normal application in a clean environment. Applications involving contaminated environments such as high levels of airborne debris (dust and waste paper); chemical or abrasive compounds; poor ground conditions; intensive usage at high performance levels; or other abnormal conditions will require more frequent servicing. At your request, your Hyster dealer will advise you of the appropriate service intervals based on an application survey.								
NOTE 6: In dirty or dusty environments, replace at 1000 hours or as needed.								
NOTE 7: Multipurpose grease with 2 to 4% Molybdenum Disulfide.								
NOTE 8: Vehicles used in paper application require regular inspection and cleaning to minimize risk of fire. This should be done at least once every 8 hours or more frequently depending upon operating environment. Use compressed air and steam clean as necessary.								
NOTE 9: Lubricate mast every three months if unit has less than 1000 hours.								
NOTE 10: Lubricate if dry or at first sign of visible surface rust.								
NOTE 11: Do not open the air filter canister except to change the air filter element. See the Periodic Maintenance Manual for your lift truck for the correct procedure to change air filter element.								
X=Check C=Change L=Lubricate CIL=Check Indicator Light during operation								



HYSTER

Maintenance Schedule

Item No.	Item	8 Hr/ 1 Day	500 Hr/ 1 Yr	1000 Hr/ 1 Yr	2000 Hr/ 1 Yr	4000 Hr/ 2 Yr	Procedure or Quantity	Specification
NOTE 12: Replace after 3000 hours. Use hour interval only.								
NOTE 13: Use Ethylene Glycol Boron-free Antifreeze. Purchase a pre-diluted 50/50 solution; or mix 50% concentrate with 50% distilled or deionized water.								
NOTE 14: Service Diesel Particulate Filter (DPF) every 3000 hours. See Hyster dealer. Use hour interval only.								
NOTE 15: For lift trucks equipped with Sideshift Carriage (with or without Fork Positioner) see section Maintenance Procedures Every 500 Hours or 1 Year, Mast Lubrication, of Periodic Maintenance 8000 SRM 1957.								
NOTE 16: Hydraulic oil sampling and analysis is a recommended practice. See Hydraulic Cleanliness Procedures 1900 SRM 1620 for oil cleanliness and water content guidelines. For lift trucks operating in heavy duty applications or highly contaminated environments, take oil samples every 500 hours. Normal operating conditions may allow for less frequent oil sampling. Oil sampling should be done just prior to all oil and filter changes.								
NOTE 17: Check at 1500 hours. Use hour interval only.								
NOTE 18: Replace filter at 8000 hours. Use hour interval only.								
NOTE 19: If lift truck is used in Paper application use ONLY JDM J20C type fluid for both the transmission and hydraulic system.								
NOTE 20: Replace filter at 1500 hours. Use hour interval only.								
NOTE 21: See Capacities and Specifications 8000SRM1958 for diesel fuel cleanliness requirements before filling lift truck tank with diesel fuel.								
X=Check C=Change L=Lubricate CIL=Check Indicator Light during operation								



Maintenance Schedule

HYSTER

Table 6. Diesel Fuel and Lube Chart

Engine Oil Specification by Diesel Fuel Type				
Engine	Diesel Fuel Type			Engine Oil Viscosity based on ambient temperature
	WWFC Diesel Category 1 500ppm<Sulfur <5000ppm	WWFC Diesel Category 2 15ppm<Sulfur <500ppm	WWFC Diesel Category 4 ASTM D975 No. 2 D S15 Sulfur<15ppm	
3.6L T3	API CF	API CF or better	API CF or better	-15 °C (5 °F) and above 15W-40 -25 °C (-13 °F) and above 10W30 Below -25 °C (-13 °F) 5W-30
3.8L T4 w/ DPF and SCR	NA	NA	API CJ-4	
3.8L T4 w/ DOC	NA	NA	API CJ-4	



HYSTER

Maintenance Schedule

Store DEF at a temperature between 10 to 40 °C (50 to 104 °F). Higher temperatures within this range reduce shelf life as shown in **Table 7**.

Table 7. DEF Storage

Storage temperature	Shelf life
10 to 20 °C (50 to 68 °F)	24 months
20 to 30 °C (68 to 86 °F)	18 months
35 °C (95 °F)	12 months
40 °C (104 °F)	3 months

Maintenance

HYSTER

Maintenance Procedures Every 8 Hours or Daily

How to Make Checks With the Engine Stopped

⚠ WARNING

Do not operate a lift truck that needs repairs. Report the need for repairs immediately. If repair is necessary, put a **DO NOT OPERATE** tag in the operator's area. If lift truck is equipped with a key switch, remove the key. Operating a lift truck that needs repair may damage lift truck and cause injury to personnel.

Put the lift truck on a level surface. Lower the carriage and forks, stop the engine, and apply the parking brake. Open both hood door assemblies and check for leaks and conditions that are not normal. Clean any oil or fuel spills. Ensure all surfaces are free of oils, lubricants, fuel and organic dust or fibers (paper, wood, cotton, agricultural grass/grain, etc.).

Tires and Wheels

Check the tires for damage (see **Figure 35**). Check the tread and remove any objects that will cause damage. Check for bent or damaged rims. Check for loose or miss-

ing hardware. Remove any wire, strapping, or other material that is wrapped around the axle.

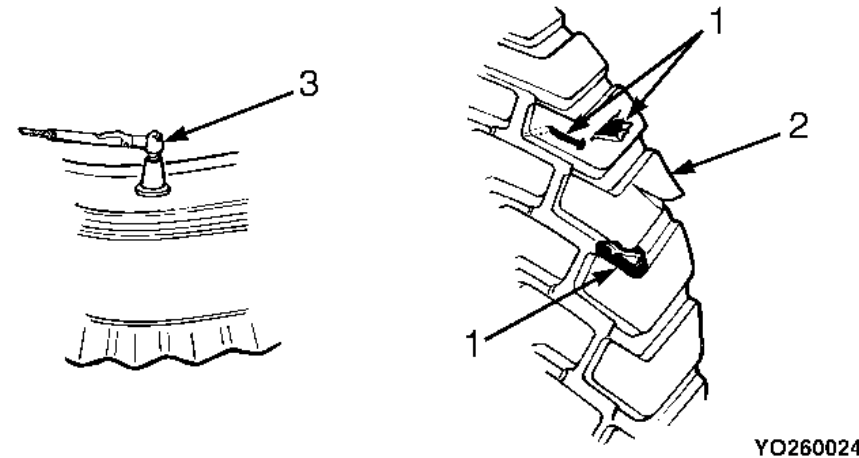

1. CHECK FOR DAMAGE (REMOVE NAILS, GLASS, AND OTHER OBJECTS FROM THE TREAD)
2. CHECK EDGES FOR WEAR
3. CHECK TIRE PRESSURE

Figure 35. Check the Tires



HYSTER

Maintenance

Safety Labels

WARNING

Safety labels are installed on the lift truck to give information about operation and possible hazards. It is important that all safety labels are installed on the lift truck and can be read to avoid damage to lift truck and injury to personnel.

Check that all safety labels are installed in the correct location on the lift truck. See the **Parts Manual**, the **Model Description** section in this **Operating Manual**, or the **Frame** section of the **Service Manual** 100 SRM 1948 for the correct location of the safety labels. See the **Parts Manual** for the part numbers of the safety labels.

Mast, Carriage, Header Hoses, Lift Chains, and Attachment

WARNING

Lower the lift mechanism completely. Never allow any person under a raised carriage. Do not put any part of your body in or through the lift mechanism unless all parts of the mast are completely lowered and the engine is STOPPED.

1. Inspect the welds on the mast, cylinders, and carriage for cracks. Make sure that the capscrews and nuts are tight.
2. Inspect the channels for wear in the areas where the rollers travel. Inspect the rollers for wear or damage.
3. Inspect the load backrest extension for cracks and damage.
4. If the lift truck is equipped with a sideshift carriage or attachment, inspect the parts for cracks and wear. Make sure the parts that fasten the sideshift carriage or attachment to the carriage are in good condition.
5. Visually inspect hoses/fittings for hydraulic leaks; hose cover for cuts, cracks, or exposed reinforcement; defective/broken clamping devices or sheaves; and proper tracking during operation. Adjust/repair/replace hose/components as necessary.
6. Check that the lift chains are correctly lubricated. Use SAE 30W engine oil to lubricate the lift chains.
7. Inspect the lift chains for cracks or broken links and worn or turned pins. Lift chains must be replaced as a set. See **Figure 36**.

Maintenance

HYSTER

8. Inspect the chain anchors and pins for cracks and damage.

9. Make sure the lift chains are adjusted so that they have equal tension. **Adjustments or replacement of the lift chains must be done by authorized personnel.**

Operator Restraint System

The seat belt, hip restraint, seat, seat plate, and seat rails are all part of the operator restraint system (see **Figure 37**). Each item must be checked to make sure it is fastened correctly, functions correctly, and is in good condition.

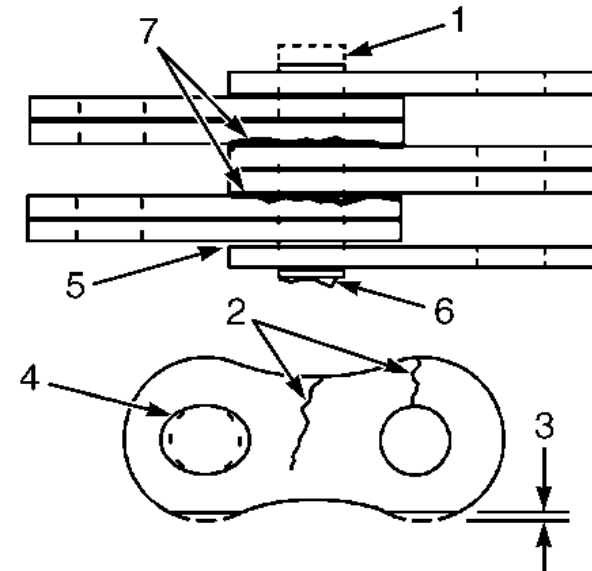

BO190158

- | | | | |
|----|-----------|----|--------------|
| 1. | WORN PIN | 5. | LOOSE LEAVES |
| 2. | CRACKS | 6. | DAMAGED PIN |
| 3. | EDGE WEAR | 7. | CORROSION |
| 4. | HOLE WEAR | | |

Figure 36. Lift Chain Check

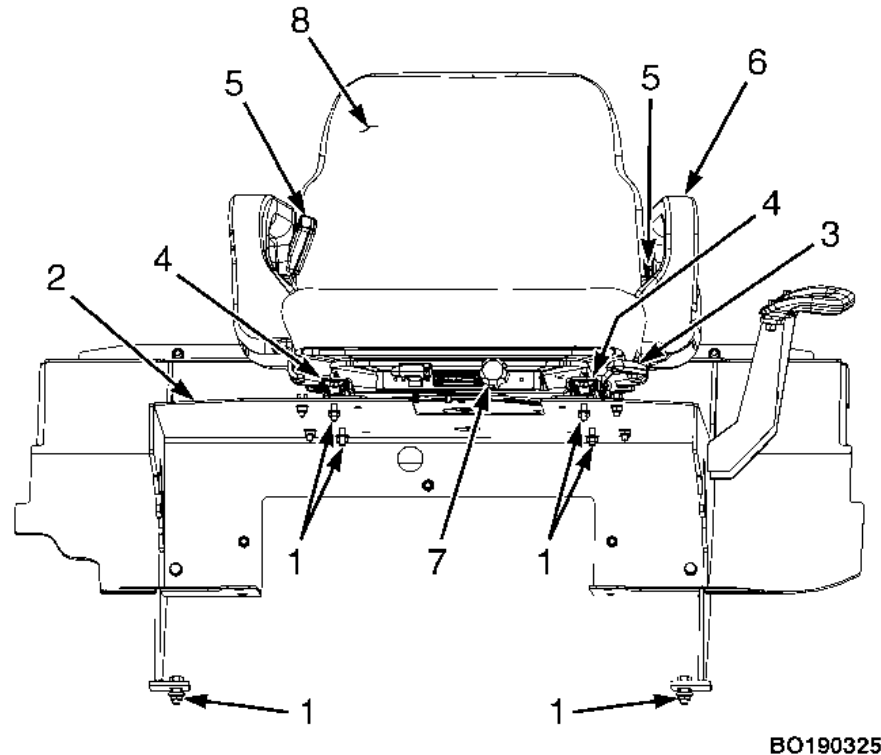

NON-SWIVEL SEAT SHOWN.

Figure 37. Seat, Seat Rail, Seat Plate, and Seat Belt Check

Legend for Figure 37

- | | |
|--------------------------------|-------------------------------|
| 1. FLANGE NUT | 5. SEAT BELT |
| 2. SEAT PLATE | 6. HIP RESTRAINT |
| 3. FORWARD/BACKWARD ADJUSTMENT | 7. OPERATOR WEIGHT ADJUSTMENT |
| 4. SEAT RAIL | 8. SEAT |

Emergency Locking Retractor (ELR)

When the ELR style seat belt is properly buckled across the operator, the belt will permit slight operator repositioning without activating the locking mechanism. If the truck tips over, travels off a dock, or comes to a sudden stop, the locking mechanism will be activated and hold the operator's lower torso in the seat. See **Figure 37**.

A seat belt that is damaged, worn, or does not operate properly will not provide protection when it is needed. The end of the belt must fasten correctly in the latch. The seat belt must be in good condition. Replace the seat belt if it is damaged or worn.

NOTE: The following seat belt operation checks must be performed three times before replacing the seat belt assembly.



Maintenance

HYSTER

- With the hood closed and in the locked position, pull the seat belt slowly from the retractor assembly. Make sure the seat belt pulls out and retracts smoothly. If the seat belt does not pull out of the retractor assembly the internal latch may be locked. Pull firmly on the seat belt and hold for a moment to remove slack from the belt in the retractor. Release the seat belt. Seat belt will retract and the internal latch will unlock. If the seat belt cannot be pulled from the retractor assembly or the belt will not retract, replace the seat belt assembly.
- With the hood closed and in the locked position, pull the seat belt with a sudden jerk. Make sure the seat belt will not pull from the retractor assembly. If the seat belt can be pulled from the retractor when it is pulled with a sudden jerk, replace the seat belt assembly.
- With the hood in the open position, make sure the seat belt will not pull from the retractor assembly. If the seat belt can be pulled from the retractor, with the hood in the open position, replace the seat belt assembly.

Seat Plate and Seat Rails

Make sure the seat rails are not loose. The seat rails must lock tightly in position, but move freely when unlocked (see **Figure 37**). The seat rails must be correctly fastened to

the seat plate and the seat plate must be secured to the frame.

Engine Compartment

Check for the presence of any combustible material such as paper, leaves etc. Remove any combustible materials.

Paper Application

Vehicles used in paper applications require regular inspection and cleaning to minimize the risk of fire. This should be done at least once every 8 hours or more frequently depending upon operating environment. The paper application will help limit the contact of paper or tissue scraps to hot surfaces under the hood doors, but frequent maintenance is required.

WARNING

Engine and exhaust system components are hot to the touch. Be sure lift truck components are cool before starting inspection and cleaning, or personal injury may occur.

Ensure the truck engine cools properly by allowing it to idle for several minutes. Shutting the truck down while hot will not allow the engine to cool quickly due to the loss of



HYSTER

Maintenance

coolant circulation. The heat trapped under the hood doors may actually increase the engine temperature because of no heat transfer through the radiator.

With engine **OFF** and lift truck components cooled, check and clean the radiator and if equipped, radiator screen. Check engine manifold, exhaust pipes, muffler, and catalytic converter for paper scraps. Clean as required. Check and clean the engine compartment components, transmission, fan shroud, belly pan, if equipped, and inside frame ledges to avoid paper, dust, and oil accumulation. Check axle and cowl openings for paper buildup and bailing wire. Remove any debris.

WARNING

Compressed air can move particles so that they cause injury to the user or to other personnel. Make sure that the path of the compressed air is away from all personnel. Wear protective goggles or a face shield to prevent injury to the eyes.

CAUTION

Air pressure, nozzle, or extension tube may cause damage to exhaust wraps and radiator fins. Assure

that air pressure, nozzle, or extension tube does not damage exhaust wraps or radiator fins.

Paper removal can generally be accomplished using a compressed air line and nozzle. An extension may be helpful to access hard to reach places. Remove floor plates and both hood doors for access to the engine compartment. Open or remove belly pan, if equipped. Clean components with compressed air. Take care to maintain the integrity of the exhaust wraps when cleaning with compressed air and use caution to not force debris into openings.

WARNING

Be careful when cleaning with steam. Steam can cause serious burns. Wear protective clothing, gloves, and eye protection. Never expose your skin to steam.

If compressed air did not adequately remove debris, steam clean to remove any persistent accumulation of material or oil. Protect electrical components from moisture when steam cleaning. Do not spray exhaust wraps directly with high pressure steam. Allow lift truck to air dry before returning to work in a contaminated environment. Paper dust and scraps will adhere to wet surfaces.



Maintenance

HYSTER

Check the condition of exhaust wraps for wear, proper fit, contamination with oil or antifreeze, gaps in coverage, and failed fasteners. Replace as necessary. Do not reuse wraps if they have been removed for some other service operation.

Fuel, Oil, and Coolant Leaks, Check

WARNING

All fuels are very flammable and can burn or cause an explosion. Do not use an open flame to check the fuel level or to check for leaks in the fuel system. If there is a leak in the fuel system, extra care must be used during the repair. Do not operate the lift truck until a leak is repaired.

Make a visual check for leaks on and under the lift truck. If possible, find and report the leak to maintenance for repair. Leaks often indicate a need for repair of damaged or worn components. Leaks in the LPG fuel system are usually not visible unless ice is present. There is however, usually a strong odor. Fuel leaks **MUST** be repaired **IMMEDIATELY**.

Check the fuel system for leaks and the condition of parts. When fuel is added to the lift truck, see the section, **How to Add Fuel to the Lift Truck**.

Also check the condition of the radiator or heater hoses that are not leaking. Soft or cracked hoses need to be replaced before a major leak occurs.

Hydraulic Hoses

Check the condition of the hydraulic hoses for serviceability by inspecting for cracks or other obvious damage. Check to insure that the hydraulic hoses are not leaking. If any hose is leaking, report it to maintenance for repair.

Coolant Hoses

Check the condition of the coolant hoses for serviceability by inspecting for cracks or other obvious damage. Check to insure that the coolant hoses are not leaking. If any hose is leaking, report it to maintenance for repair.

Steering Column Gas Cylinder

Make sure the gas cylinder for the steering column operates correctly. The cylinder must **NOT** allow the column to move unless the tilt lever is released. See **Figure 38**.

HYSTER

Maintenance

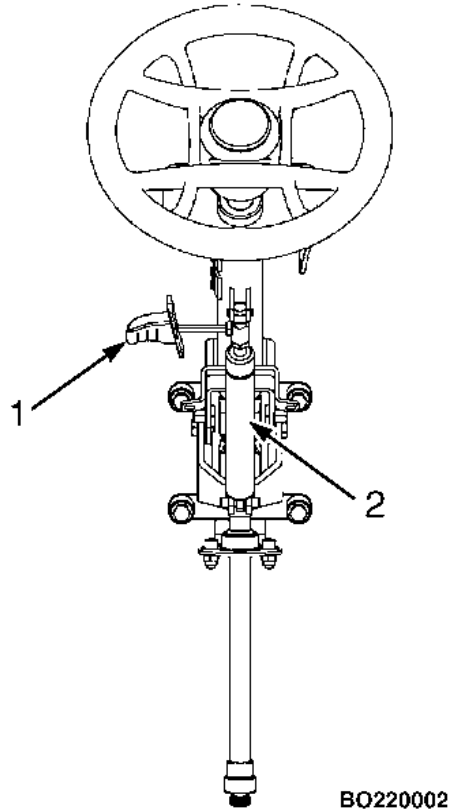

1. TILT LEVER

2. GAS CYLINDER

Figure 38. Steering Column Gas Cylinder and Tilt Lever

Transmission

NOTE: The transmission oil dipstick and transmission oil breather are one unit. See **Figure 39**.

Check the transmission for leaks and damage or loose components. Heavy-duty or high-temperature operations can require more frequent checks. See **Figure 39**.

Hydraulic System Oil

WARNING

At operating temperature the hydraulic oil is **HOT**. Do not permit the hot oil to touch the skin and cause a burn.

CAUTION

Do not permit dirt to enter the hydraulic system when the oil level is checked or the filter is changed.

Never operate the hydraulic pump without oil in the hydraulic system. The operation of the hydraulic pump without oil will damage the pump.



Maintenance

HYSTER

After the engine has stopped, wait one minute before checking the oil level. Keep oil at the correct level as indicated on the dipstick (see **Figure 39**). Use the correct oil as shown in the **Maintenance Schedule**.

Check the hydraulic system for leaks and damaged or loose components. Heavy-duty or high-temperature operations can require more frequent checks.

Engine Oil

WARNING

At operating temperature, the engine oil is **HOT**. Do not permit the hot oil to touch the skin and cause a burn.

CAUTION

Do not permit dirt to enter the engine when the oil level is checked or the filter is changed.

Never operate the engine without oil. The operation of the engine without oil will damage the engine.

After the engine has stopped, wait one minute before checking the oil level. See **Figure 40**, **Figure 41**, **Figure 42**, **Figure 43**, and **Figure 44**. Keep the oil at the correct level as indicated on the dipstick. Use the correct oil as shown in the **Maintenance Schedule**.

HYSTER

Maintenance

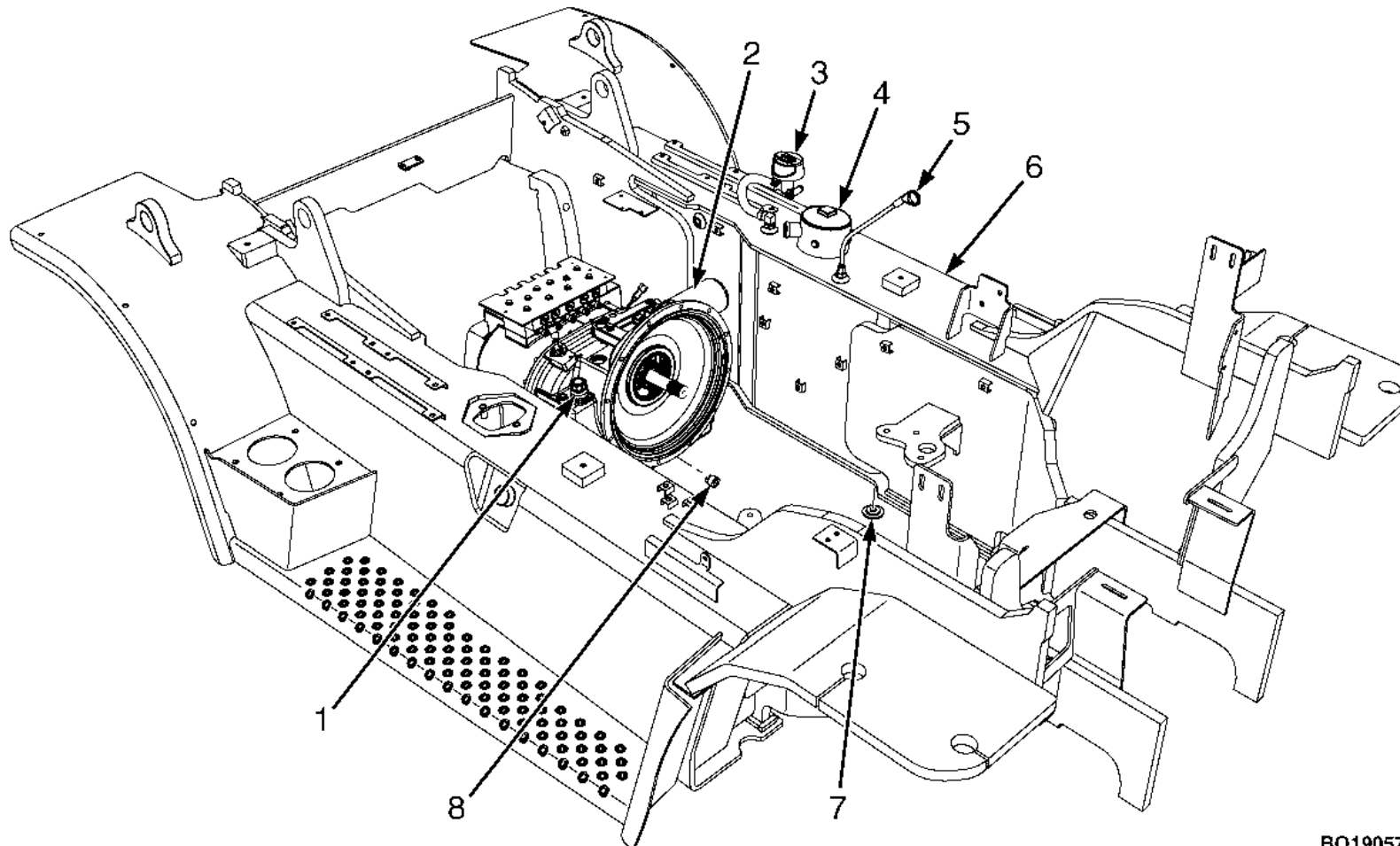

1. TRANSMISSION OIL
DIPSTICK/BREATHER
2. TRANSMISSION OIL
FILTER
3. HYDRAULIC TANK
BREATHER
4. HYDRAULIC OIL
FILTER
5. HYDRAULIC OIL
DIPSTICK
6. HYDRAULIC TANK
7. HYDRAULIC OIL
DRAIN PLUG
8. TRANSMISSION OIL
DRAIN PLUG

BO190579

Figure 39. Transmission and Hydraulic Oil Checks

Maintenance

HYSTER

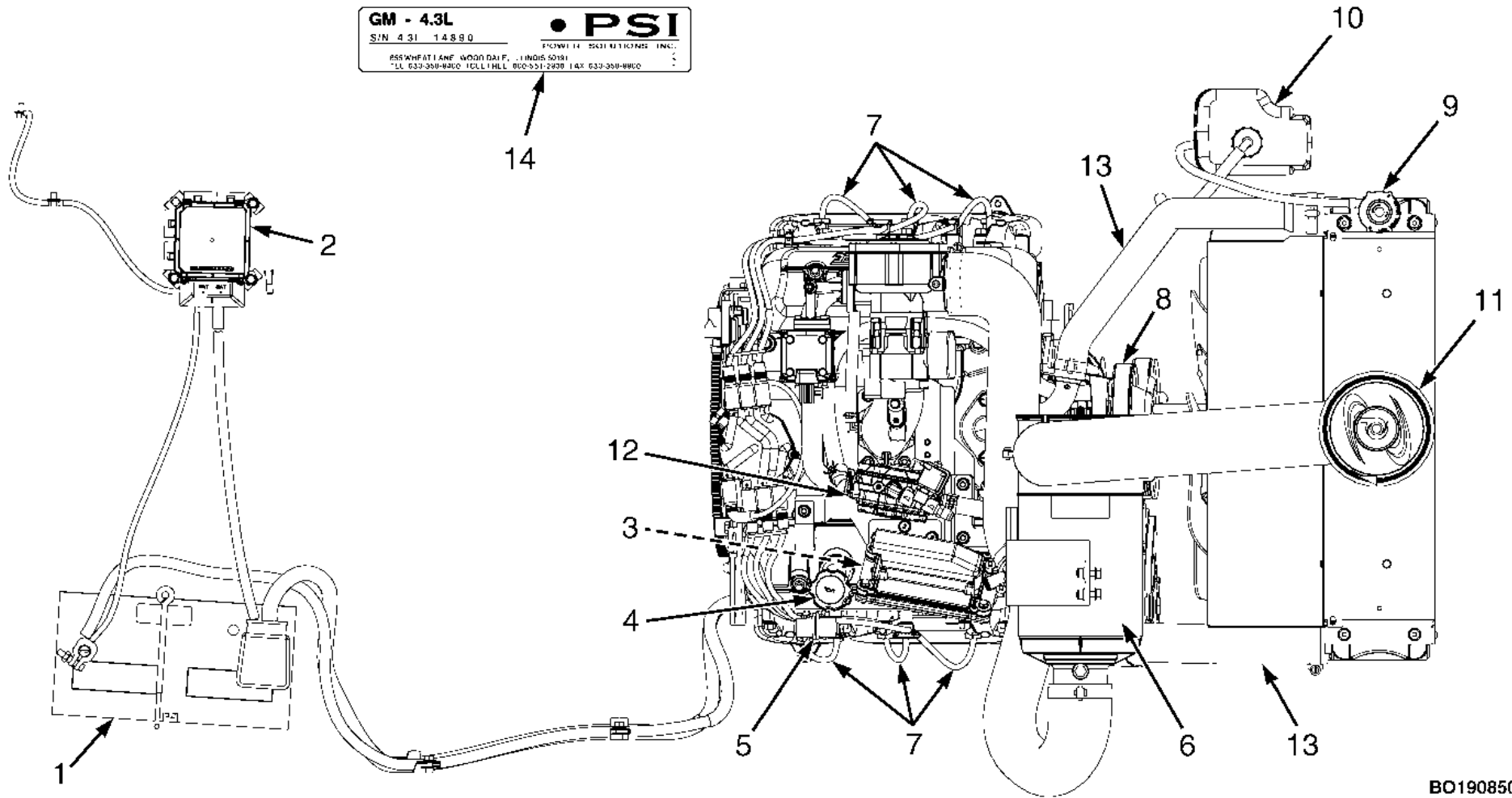

BO190850

Figure 40. Engine Maintenance Points - GM 4.3L With PSI Fuel System Installed



HYSTER

Maintenance

Legend for Figure 40

- | | |
|------------------------------------|---------------------------------|
| 1. BATTERY | 8. DRIVE BELT |
| 2. POWER DISTRIBUTION MODULE (PDM) | 9. RADIATOR CAP |
| 3. LPG FUEL FILTER ASSEMBLY | 10. AUXILIARY COOLANT RESERVOIR |
| 4. ENGINE OIL FILL | 11. AIR FILTER PRECLEANER |
| 5. ENGINE OIL DIPSTICK | 12. LPG CONVERTER |
| 6. AIR FILTER | 13. COOLANT HOSES |
| 7. SPARK PLUGS | 14. ENGINE LABEL |

Maintenance

HYSTER

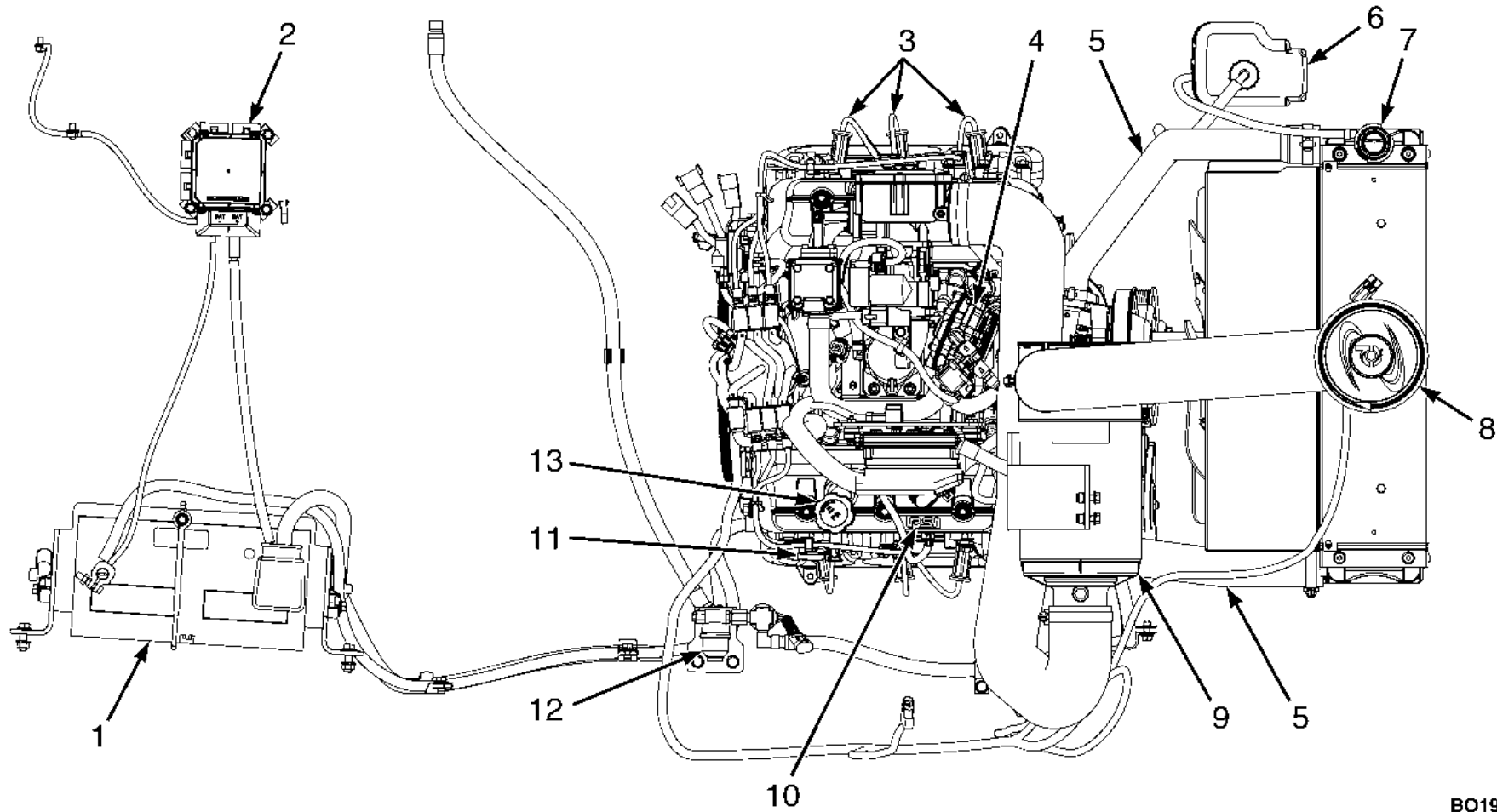

BO191615

Figure 41. Engine Maintenance Points - PSI 4.3L



HYSTER

Maintenance

Legend for Figure 41

- | | | | |
|----|---------------------------------|-----|--------------------------|
| 1. | BATTERY | 8. | AIR FILTER PRE-CLEANER |
| 2. | POWER DISTRIBUTION MODULE (PDM) | 9. | AIR FILTER |
| 3. | SPARK PLUGS | 10. | ENGINE MANUFACTURER ID |
| 4. | LPG CONVERTER | 11. | ENGINE OIL DIPSTICK |
| 5. | COOLANT HOSES | 12. | LPG FUEL FILTER ASSEMBLY |
| 6. | AUXILIARY COOLANT RESERVOIR | 13. | ENGINE OIL FILL |
| 7. | RADIATOR CAP | | |

Maintenance

HYSTER

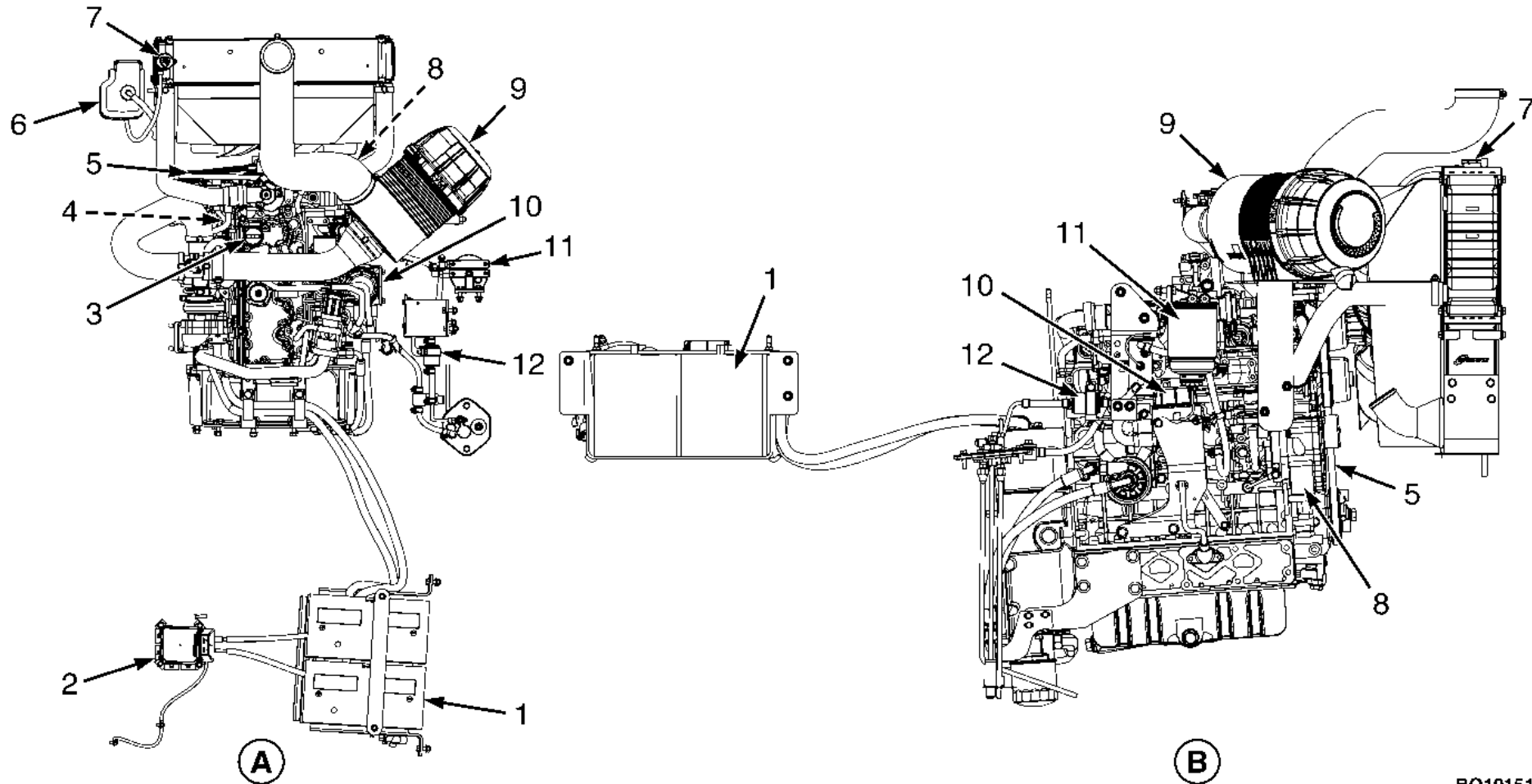

BO191512

Figure 42. Engine Maintenance Points - Kubota 3.8L T4 Final Diesel



HYSTER

Maintenance

Legend for Figure 42

A. TOP VIEW

1. BATTERY
2. POWER DISTRIBUTION MODULE (PDM)
3. ENGINE OIL CAP
4. ENGINE OIL DIPSTICK
5. DRIVE BELT
6. AUXILIARY COOLANT RESERVOIR

B. LEFT-SIDE VIEW

7. RADIATOR CAP
8. FUEL INJECTION PUMP
9. AIR FILTER
10. CRANKCASE BREATHER
11. WATER SEPARATOR
12. IN-LINE FUEL STRAINER

Maintenance

HYSTER

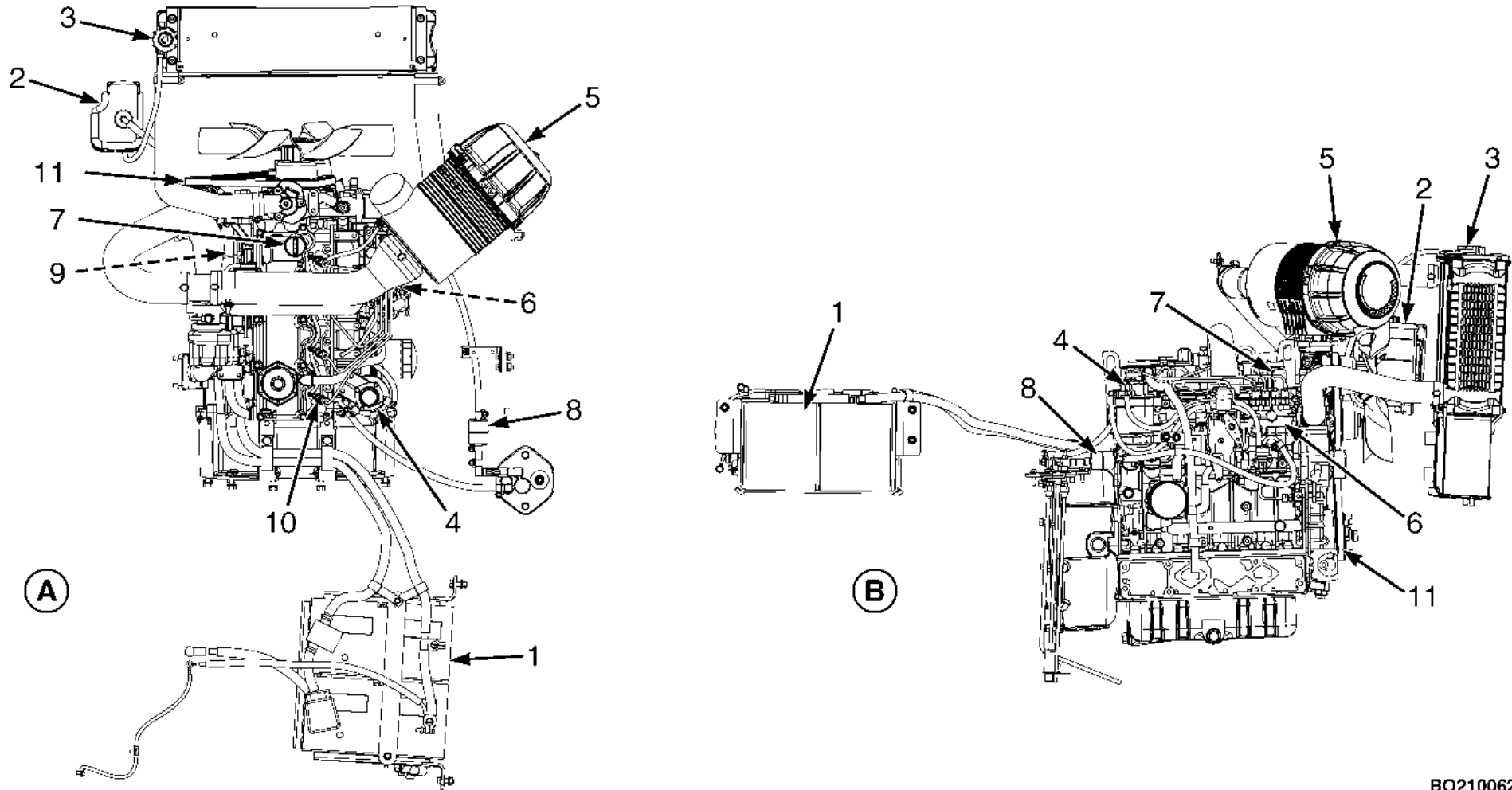

BO210062

Figure 43. Engine Maintenance Points - Kubota 3.6L Diesel



HYSTER

Maintenance

Legend for Figure 43

A. TOP VIEW

1. BATTERY
2. AUXILIARY COOLANT RESERVOIR
3. RADIATOR CAP
4. WATER SEPARATOR
5. AIR FILTER
6. FUEL INJECTION PUMP

B. LEFT-SIDE VIEW

7. ENGINE OIL CAP
8. IN-LINE FUEL STRAINER
9. ENGINE OIL DIPSTICK
10. FUEL INJECTOR
11. DRIVE BELT

Maintenance

HYSTER

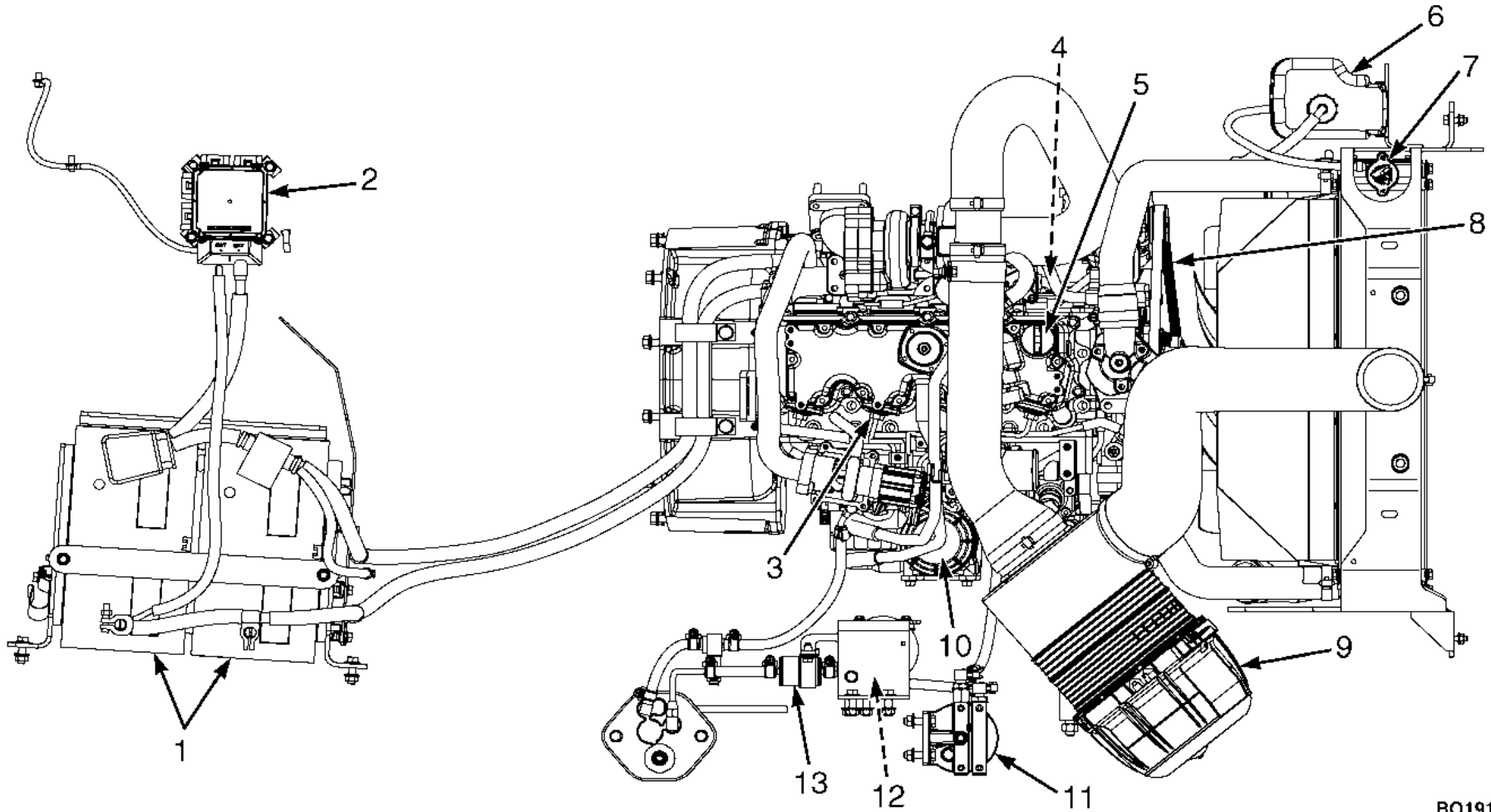

BO191613

Figure 44. Engine Maintenance Points - Kubota 3.8L 55kW Diesel



HYSTER

Maintenance

Legend for Figure 44

- | | |
|--------------------------------|------------------------|
| 1. BATTERY | 8. DRIVE BELT |
| 2. PDM | 9. AIR FILTER |
| 3. FUEL INJECTOR | 10. CRANKCASE BREATHER |
| 4. ENGINE OIL DIPSTICK | 11. WATER SEPARATOR |
| 5. ENGINE OIL CAP | 12. FUEL PUMP |
| 6. AUXILIARY COOLANT RESERVOIR | 13. IN-LINE STRAINER |
| 7. RADIATOR CAP | |

Air Filter

The air filter canister should not be opened until an air filter element replacement is required. An air filter element replacement is required when one of the following occurs:

- the optional air flow restriction indicator light on the dash illuminates
- the optional manual air flow indicator button pops up
- the specified number of hours has passed since the last filter element replacement

Do not operate the lift truck until the air filter element has been replaced.

Forks

NOTE: Forks must be removed or installed by trained personnel only.

The identification of a fork describes how the fork is connected to the carriage. These lift trucks have hook forks.

Forks, Remove

WARNING

Do not try to move a fork without a lifting device. Each hook fork for these lift trucks can weigh 66 to 183 kg (145 to 402 lb). Removing a fork without a lifting device can result in serious injury to personnel.

NOTE: Forks are to be replaced only in sets and not individually.

Maintenance

HYSTER

A fork can be removed from the carriage for replacement of the fork or other maintenance. Slide a hook fork to the fork removal notch on the carriage. See **Figure 45** and **Figure 46**. Lower the fork onto blocks so that the bottom hook of the fork moves through the fork removal notch. See **Figure 46**. Lower the carriage further so that the top hook of the fork is disengaged from the top carriage bar. Move the carriage away from the fork, or use a lifting device to move the fork away from the carriage.

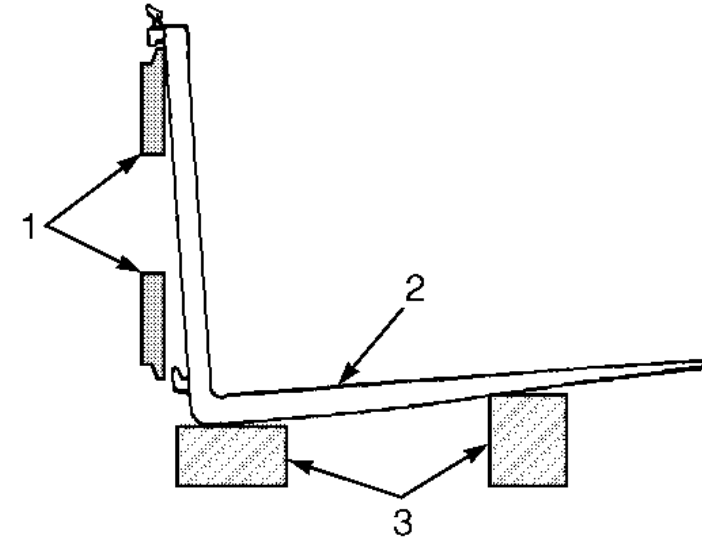

BO190156

1. CARRIAGE BARS
2. HOOK FORK
3. BLOCKS

Figure 45. Remove a Hook Fork

HYSTER

Maintenance

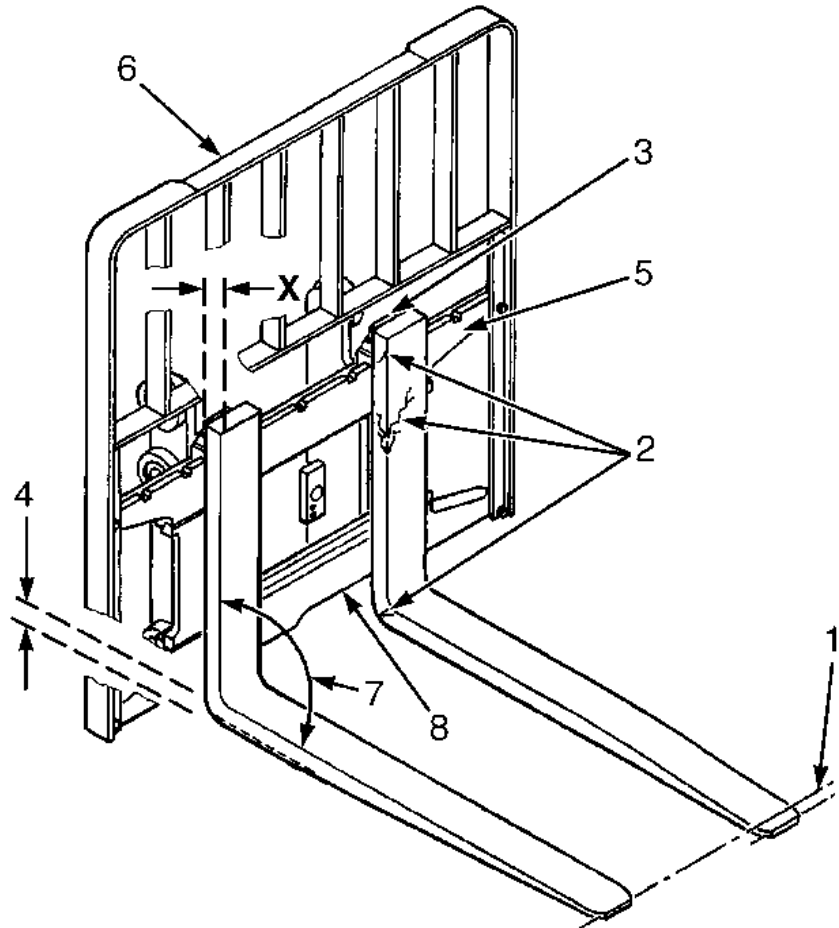

Fork Tip Alignment	
Length of Forks	3% Dimension
1200 mm (47 in.)	36 mm (1.42 in.)
1300 mm (51 in.)	39 mm (1.53 in.)
1500 mm (59 in.)	45 mm (1.77 in.)
1800 mm (71 in.)	54 mm (2.13 in.)
2400 mm (94 in.)	72 mm (2.83 in.)

1. TIP ALIGNMENT (MUST BE WITHIN 3% OF FORK LENGTH)
2. CRACKS
3. LATCH DAMAGE
4. HEEL OF FORK (MUST BE 90% OF DIMENSION "X")
5. CARRIAGE
6. LOAD BACKREST EXTENSION
7. MAXIMUM ANGLE 93°
8. FORK REMOVAL NOTCH

BO190157

Figure 46. Forks Check



Maintenance

HYSTER

Forks, Inspect

1. Inspect the forks for cracks and wear. Check that the fork tips are aligned as shown in **Figure 46**. Check that the bottom of the fork is not worn (Item 4 in **Figure 46**).

2. Replace any damaged or broken parts that are used to keep the forks locked in position. See **Figure 48**.

3. Inspect fork wear. Ensure heel wear is not more than 10% of original thickness. If fork wear is more than 10%, fork must be replaced or rerated. Perform fork wear inspection using a BOL256N1 caliper ruler Hyster P/N 4092984 as follows. See **Figure 47**.

a. Determine normal thickness of "N" of fork using scale or ruler portion of caliper ruler. Measurement has to be done on fork shank using caliper ruler.

b. Position caliper at end of heel internal radius (item 4, **Figure 46**) with opening corresponding to measured thickness of fork shank in **Step a** above. (e.g. for N 1.75 use N 1.75 opening). This is typically the section of fork where wear is greatest. Note that opening distance has been reduced by 10% from nominal thickness.

c. If fork enters opening, it is mandatory to replace it. DANGER OF BREAKING. Furthermore, a 10% reduc-

tion in fork blade thickness results in 20% reduction in operating capacity.

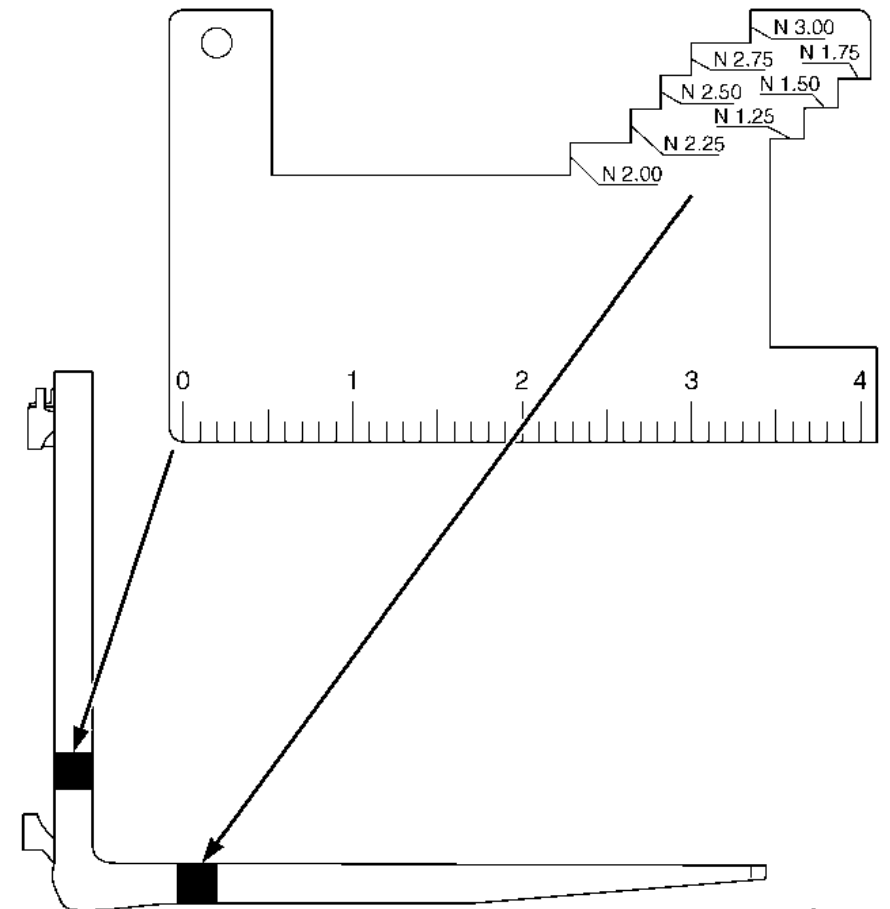

BO191812

Figure 47. Fork Wear Check

HYSTER

Maintenance

Forks, Install

Move the fork and carriage so that the top hook on the fork can engage the upper carriage bar. Raise the carriage to move the lower hook through the fork removal notch. Slide the fork on the carriage so that both upper and lower hooks engage the carriage. Engage the lock pin with a notch in the upper carriage bar. See **Figure 48**.

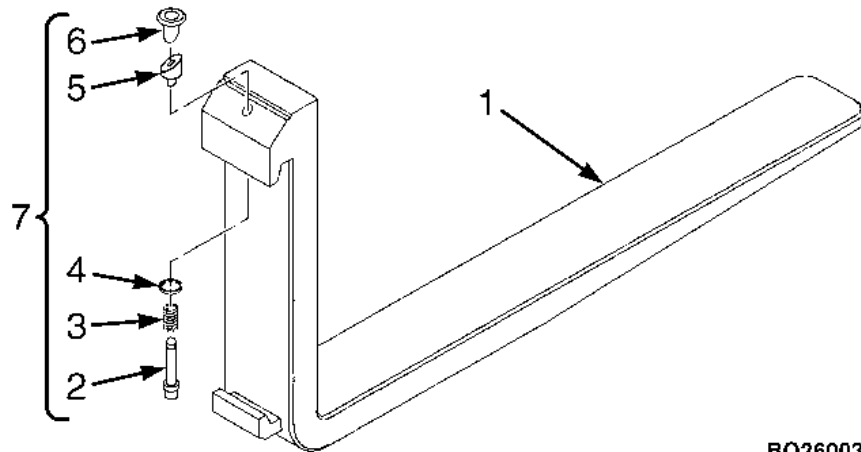

- | | | | |
|----|----------|----|-------------------|
| 1. | FORK | 5. | WEDGE |
| 2. | LOCK PIN | 6. | KNOB |
| 3. | SPRING | 7. | LOCK PIN ASSEMBLY |
| 4. | WASHER | | |

Figure 48. Fork Lock Pin Assembly

Forks, Adjust

NOTE: During the adjustment of the forks, the heel of the forks should not be touching the ground.

The forks are connected to the carriage by hooks and lock pins. See **Figure 45** and **Figure 48**. The lock pins are installed through the top fork hooks and fit into slots in the top carriage bar. If pin does not remain engaged in carriage slot, replace with new pin. Adjust the forks as far apart as possible for maximum support of the load. Hook forks will slide along the carriage bars to adjust for the load to be lifted. Raise the lock pin in each fork to slide the fork on the carriage bar. Make sure the lock pin is engaged in the carriage bar to lock the fork in position after the width adjustment is made.



Maintenance

HYSTER

Hang On Sideshift Carriage

Check for cracks, wear, and damage. If damaged, see the section **Mast Repairs 2- and 3-Stage Mast** 4000 SRM 1956 for repair procedures. If necessary, lubricate sliding surfaces (upper bearings) at grease fittings and lower bearing strips with multipurpose grease shown in the **Maintenance Schedule**. See **Figure 49**.

If the lift truck is equipped with a fork positioner, lubricate fork positioner carrier at grease fittings and the fork cylinder rod anchors with multipurpose grease shown in the **Maintenance Schedule**. See **Figure 49**.

HYSTER

Maintenance

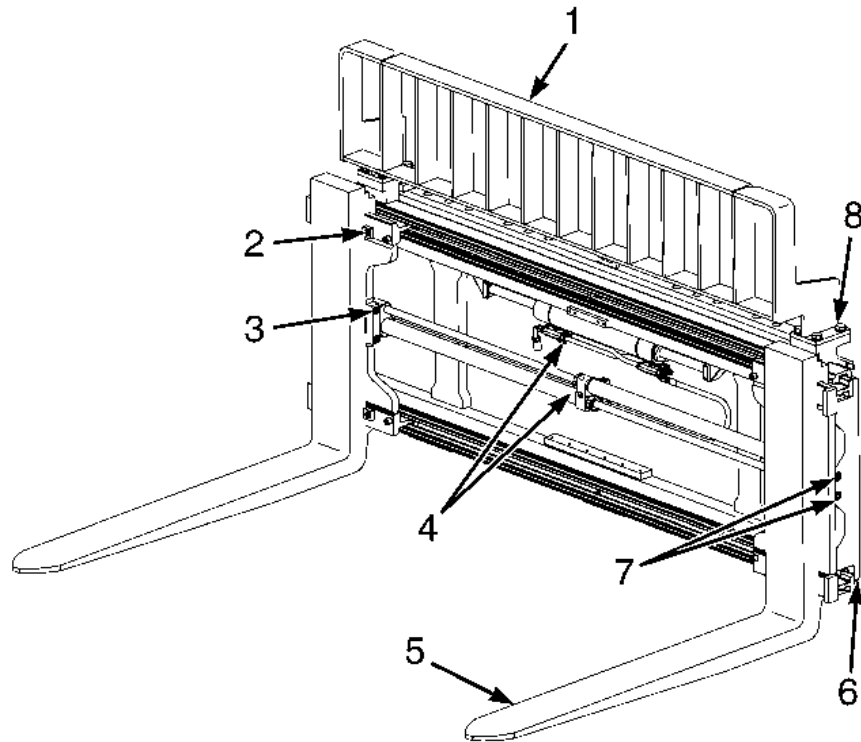

1. BACKREST
2. FORK CARRIER RETAINER CAPSCREWS
3. CYLINDER ANCHOR BAR CAPSCREWS
4. CYLINDERS AND HOSES
5. FORKS
6. LOWER HOOKS
7. MOUNTING FLANGE CAPSCREWS
8. BACKREST CAPSCREWS

BO190982

Figure 49. Hang On Sideshift Carriage With Fork Positioner



Maintenance

HYSTER

How to Make Checks With the Engine Running

WARNING

DO NOT operate a lift truck that needs repairs. Report the need for repair immediately. If repair is necessary, put a **DO NOT OPERATE** tag in the operator's area. If lift truck is equipped with a key switch, remove the key. If a lift truck requiring repair is operated, damage to lift truck and injury to personnel can occur.

WARNING

FASTEN YOUR SEAT BELT! The seat belt is installed to help the operator stay on the truck if the lift truck tips over. **IT CAN ONLY HELP IF IT IS FASTENED.**

Make sure that the area around the lift truck is clear before starting the engine or making any checks of the operation.

Be careful when making the checks. If the lift truck is stationary during a check, apply the parking brake and put the transmission in **NEUTRAL**. Make the checks carefully.

Indicator Lights, Horn, Fuses, and Relays

If lift truck is equipped with a key switch, turn key to **ON** position. If lift truck is equipped with a Power **ON/OFF** button, press button to turn system power on. Check all indicator lights for correct operation as described in **Table 2**. Check the operation of the horn. Start the engine by turning the key switch to the **START** position, if truck is equipped with a key switch, or press the engine start button, if truck is equipped with this button. If any of the indicator lights do not operate correctly, check the fuses. The fuses are located in the Power Distribution Module (PDM) which is located under the floor plates mounted on the right side of the lift truck frame. See **Figure 50**.

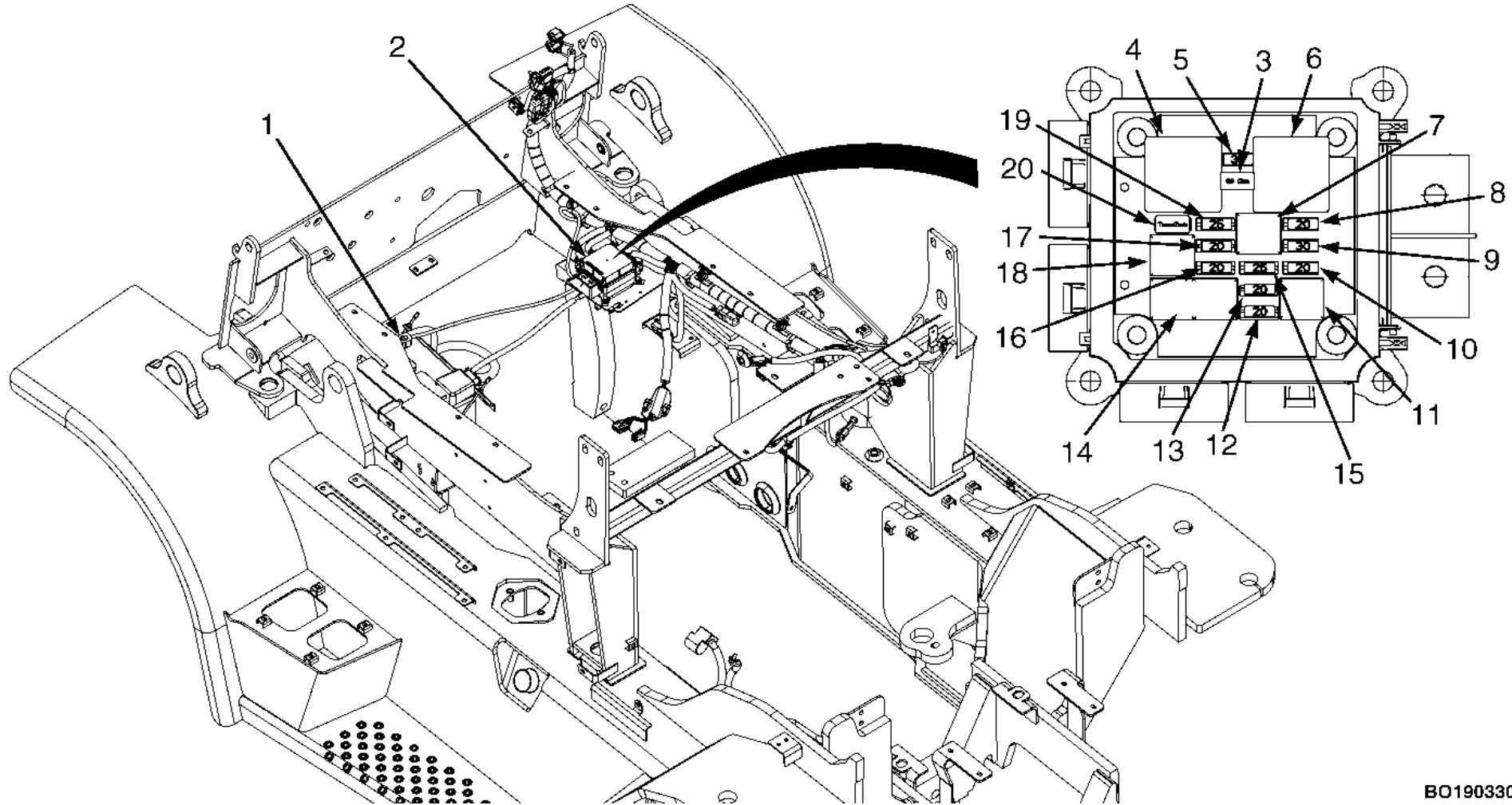

BO190330

Figure 50. PDM Showing Fuses and Relays



Maintenance

HYSTER

Legend for Figure 50

NOTE: FLOOR PLATES REMOVED FOR CLARITY.

- | | |
|--|--|
| <ol style="list-style-type: none"> 1. BATTERY 2. POWER DISTRIBUTION MODULE (PDM) 3. RESISTOR (68 OHM) 4. START RELAY 5. STARTER (30 AMP FUSE) 6. IGNITION 3 RELAY 7. BACKUP RELAY 8. BACKUP (20 AMP) 9. IGNITION (30 AMP) 10. SPARE FUEL PUMP (20 AMP) | <ol style="list-style-type: none"> 11. SPARE FUEL PUMP RELAY 12. BATTERY (20 AMP) 13. FRONT WORK LIGHT (20 AMP) 14. FRONT/REAR WORK LIGHT RELAYS 15. BATTERY (25 AMP) 16. REAR WORK LIGHT (20 AMP) 17. IGNITION 1 (20 AMP) 18. IGNITION RELAY 19. BATTERY (25 AMP) 20. SEMICONDUCTOR TRANSZORB |
|--|--|

Service Brakes

Brake Oil Level

WARNING

Small amounts of water in the brake system can cause reduced braking performance if the water reaches the wheel cylinder area. Do not allow water entry. Ensure that the sealed reservoir lid is properly replaced.

The brake system has a boosted master cylinder. Braking will be more difficult if the engine is not running.

Loss of oil from the brake oil reservoir indicates a leak. Repair the brake system before using the lift truck.

Replace the brake oil in the system if there is dirt or water in the system.

DO NOT use "DOT" fluid, only use Dexron III oil from sealed container to prevent possible damage to the brake system.

Failure to observe the above warnings could result in death or serious injury.

There is an indicator light on the Display Switch Cluster for the brake oil. The red light is **ON** when the key switch is in the **START** position or the Power **ON/OFF** button is pressed, and must go **OFF** when the engine is running. If



HYSTER

Maintenance

the light is **ON** when the engine is running, the brake fluid level in the reservoir is too low.

Operation, Check

Check the operation of the service brakes. Push on the inching/brake pedal. The service brakes must be applied before the inching/brake pedal reaches the floor plate. The pedal must stop firmly and must not move slowly down after the brakes are applied. The service brakes must apply equally to both drive wheels. The service brakes must not pull the lift truck to either side of the direction of travel when they are applied. The service brakes are automatically adjusted when the lift truck is moving and the brakes are firmly applied. Full application of the inching/brake pedal applies the service brakes and puts the transmission in **NEUTRAL**.

Lift trucks with a MONOTROL® pedal: when the inching/brake pedal is fully applied, a switch in the starting circuit is closed so that the engine can be started.

Parking Brake

There is an indicator icon on the display panel for the parking brake. This icon is illuminated as described in the **Model Description** section of this manual. There is a sen-

sor in the seat that actuates an audible alarm. If the operator leaves the seat, with system power **OFF**, without applying the parking brake, the alarm will sound for 10 seconds until the parking brake is applied or the operator sits back on the seat. If system power is **ON** or the engine is running, and the operator leaves the seat, without applying the parking brake, the alarm will sound continuously until parking brake is applied or the operator sits back on the seat.

Make sure the service brakes operate correctly before checking the operating of the parking brake. Check the operation of the parking brake. The parking brake, when in good condition and correctly adjusted, will hold a lift truck with a full capacity load on a 15% grade [a slope that increases 1.5 meters in 10 meters (1.5 feet increase in 10 feet)]. If parking brake requires adjustment, notify service personnel.

Engine Oil Pressure

NOTE: The 4.3L engine will enter shutdown mode after a warning buzzer sounds and a 30-second countdown if engine oil pressure is less than 34.5 kPa (5 psi) on lift trucks with powertrain protection system. Lift trucks equipped with a Kubota diesel engine will enter shutdown mode



Maintenance

HYSTER

when the engine oil pressure is less than 49 kPa (7 psi) on lift trucks with powertrain protection system. See **Engine Shutdown** procedures in the **Operating Procedures** section in this manual.

There is an indicator light for the engine oil pressure on the Display Switch Cluster. During normal operation, the red indicator light will illuminate when the key switch is turned to **ON**, if the truck is equipped with a key switch, or when the power **ON/OFF** button is pressed, and will stay illuminated until correct minimum oil pressure is obtained, at which time the light will go off.

If the light continues to stay on when the engine is running, the engine oil pressure is low. Stop the engine and check the oil level. See **Figure 40**, **Figure 41**, **Figure 42**, **Figure 43**, or **Figure 44**. Do not restart the engine until the low pressure condition has been corrected.

Cooling System

WARNING

DO NOT remove the radiator cap from the radiator when the engine is hot. When the radiator cap is removed, the pressure is released from the system. If

the system is hot, the steam and boiling coolant can cause burns.

NOTE: The engine will enter shutdown mode after a warning buzzer sounds and a 30-second countdown, if coolant temperature reaches 118 °C (245 °F) or above, for GM or PSI 4.3L on lift trucks with powertrain protection system. Lift trucks equipped with a Kubota diesel engine will enter the shutdown mode when the coolant temperature reaches 115 °C (240 °F) or above on lift trucks with powertrain protection system. See **Engine Shutdown** procedures in the **Operating Procedures** section in this manual.

There is an indicator light on the Display Switch Cluster for the coolant temperature. The red light is **ON** when the key switch is in the **START** position or the Power **ON/OFF** button is pressed, and must go **OFF** when the engine is running. If the light is **ON** when the engine is running, the coolant and engine are too hot. Stop the engine and check the coolant level in the coolant recovery reservoir.

Make sure the coolant level is between the **ADD** and **FULL** marks on the auxiliary coolant reservoir (See **Figure 51**). The coolant will expand as it is heated and the level in the auxiliary coolant reservoir will increase.

HYSTER

Maintenance

CAUTION

Additives may damage the cooling system. Before using additives, contact your local Hyster dealer.

If coolant is added, use the correct mixture of water and ethylene glycol shown in the **Maintenance Schedule**.

WARNING

Compressed air can move particles so that they cause injury to the user or to other personnel. Make sure that the path of the compressed air is away from all personnel. Wear protective goggles or a face shield to prevent injury to the eyes.

Turn engine OFF and check the radiator fins. Clean the radiator with compressed air or water as needed.

Check for and remove any debris on the radiator core. If the indicator light turns on again after restarting, shut down the lift truck and do not operate the lift truck until the problem is corrected.

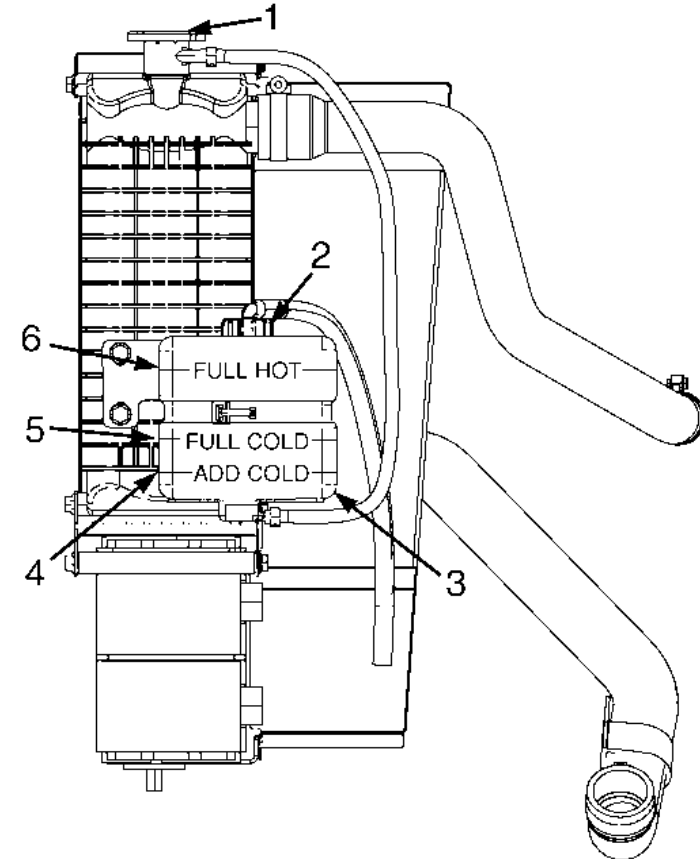

BO190331

Figure 51. Auxiliary Coolant Reservoir



Maintenance

HYSTER

Legend for Figure 51

- | | |
|--------------------------------|---------------------|
| 1. RADIATOR CAP | 4. ADD MARK |
| 2. FILL CAP | 5. FULL MARK (COLD) |
| 3. AUXILIARY COOLANT RESERVOIR | 6. FULL MARK (HOT) |

Steering System

WARNING

The lift truck has hydraulic power steering. The steering can be difficult if the engine is not running and can cause injury to personnel.

Make sure the steering system operates smoothly and provides good steering control. Make sure the steering column can be adjusted and the gas cylinder function is correct.

Control Levers and Pedals

Check that the control levers for the transmission, mast, and attachment operate as described in **Table 3**. Check that the pedals operate correctly as described in **Table 3**.

Lift System Operation

WARNING

When working on or near the mast, see **Safety Procedures When Working Near the Mast in the Periodic Maintenance 8000 SRM 1957**.

Lower the lift mechanism completely. Never allow any person under a raised carriage. Do not put any part of your body in or through the lift mechanism unless all parts of the mast are completely lowered and the engine is STOPPED. Serious injury to personnel can result if lift mechanism is not lowered completely.

If the mast cannot be lowered, use chains on the mast weldments and carriage so that they cannot move. Make sure the moving parts are attached to a part that does not move. See the Periodic Maintenance section of the Service Manual for additional information.

Do not try to find hydraulic leaks by putting hands on pressurized hydraulic components. Hydraulic oil can be injected into the body by the pressure and cause serious injury to personnel.

Perform the following checks and inspections:



HYSTER

Maintenance

1. Turn engine OFF and check for leaks in the hydraulic system. Check the condition of the hydraulic hoses and tubes.

NOTE: Some parts of the mast move at different speeds during raising and lowering.

2. Slowly raise and lower the mast several times without a load. Raise the mast to its full height at least once. The mast components must raise and lower smoothly in the correct sequence. Hose must track properly during operation.

3. The inner weldments and the carriage must lower completely.

4. Raise the mast 1 m (3 ft) with a capacity load. The inner weldments and the carriage must raise smoothly. Lower the mast. All moving components must lower smoothly.

5. Lower the load to approximately 0.3 m (1 ft). Tilt the mast forward and backward. The mast must tilt smoothly and both tilt cylinders must stop evenly.

6. Check that the controls for the attachment operate the functions of the attachment. See the symbols by each of the controls. Make sure all of the hydraulic lines are connected correctly and do not leak.

Air Filter

There is an indicator light on the Display Switch Cluster (see **Figure 6** and **Table 2**) for the air filter. The amber light is **ON** when the key switch is in the **START** position or the Power **ON/OFF** button is pressed, and must go **OFF** when the engine is running. If the light is **ON** when the engine is running, there is a restriction in the air filter. Turn engine **OFF** and remove restriction from air filter. See the **Periodic Maintenance** section of the **Service Manual** for procedures. See **Figure 52**.

Maintenance

HYSTER

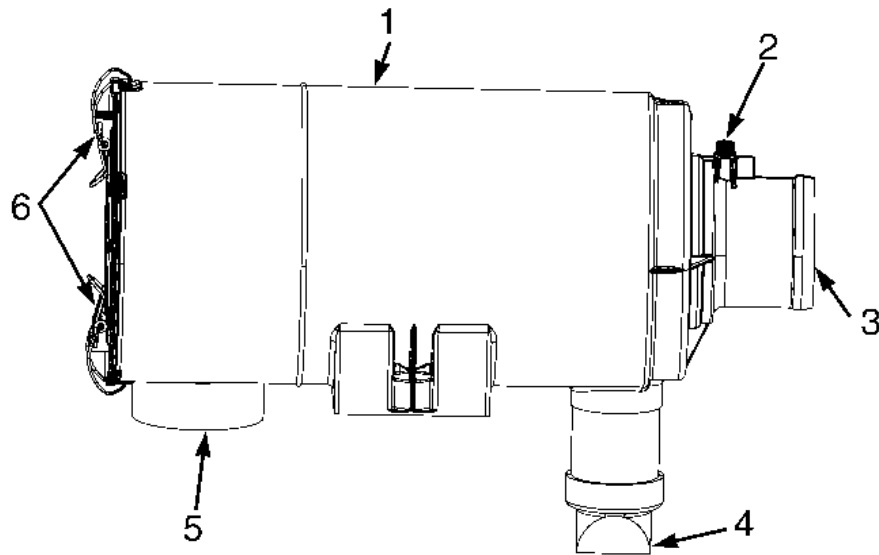

BO190275

1. AIR FILTER COVER
2. RESTRICTION INDICATOR PORT
3. AIR OUTLET
4. DUST DISCHARGE VALVE
5. AIR INLET
6. COVER LATCHES

Figure 52. Air Filter

Fuel/Water Separator Filter, Kubota Diesel Engine

On the Kubota 3.8L diesel engine, this amber indicator light (see **Figure 6** and **Table 2**) will illuminate if the sensor on the fuel/water separator filter indicates that water must be drained from the filter. See **Figure 42** or **Figure 44**. Check Kubota 3.6L fuel/water separator filter daily for water accumulation. See **Figure 43**. See **Periodic Maintenance 8000 SRM 1957** for procedures to drain water and change the filter.

How to Add Fuel to the Lift Truck

WARNING

Stop the engine. Turn the key switch to OFF, if truck is equipped with a key switch; or press the Power ON/OFF button. The operator must be off the lift truck while fuel is added.

No smoking.

All fuels for internal combustion engines are very flammable.

Fill the fuel tank only in a designated area with good ventilation. Have a fire extinguisher available.



HYSTER

Maintenance

Never fill the fuel tank near an open flame or near equipment that can create sparks. Never check fuel level or check for leaks with an open flame.

Breathing fuel vapor may cause nausea, unconsciousness, or death. Long-term exposure to gasoline vapors may cause liver or kidney damage and cancer. Avoid breathing vapor.

Liquefied Petroleum Gas (LPG)

WARNING

Close the fuel valve on the tank when the lift truck is not in active use. Do not park the lift truck near heat or ignition sources.

LPG is extremely flammable. When checking or filling an LPG tank: No smoking. Stop engine.

Frost on the surface of the tank, the valves, or the fittings and the odor of LPG fuel indicates a leak. Inspect the LPG system and repair a leak immediately. An LPG fuel leak creates an explosion and fire hazard. Do not attempt to start the engine if there is a leak in the LPG fuel system.

Only trained and authorized personnel are permitted to operate filling equipment.

Use only the LPG tank indicated on the label on the tank bracket. Do not use an LPG tank that is damaged. A damaged LPG tank must be removed from service.

WARNING

LPG tanks are heavy. The weight of an LPG tank can exceed the maximum recommended weight for safe lifting by an individual. Get assistance when lifting or lowering an LPG tank. Use correct lifting procedures.

LPG can cause an explosion. Do not cause sparks or permit flammable material near the LPG system. LPG fuel systems can be disconnected indoors only if the lift truck is at least 8 m (26 ft) from any open flame, motor vehicles, electrical equipments, or ignition source.

Removable LPG tanks must be removed from the fork lift before filling. If the lift truck is equipped with a non-removable LPG tank, make sure all components (engine, transmission, muffler, catalytic muffler) have surface temperatures that have cooled to below 427 °C (800 °F).



Maintenance

HYSTER

LPG Tank, Removal

NOTE: The single or dual LPG tank(s) and bracket(s) are mounted on the right side step weldment of lift truck frame. The procedures described below are for the dual LPG tanks and brackets. Single tank and bracket procedures are similar.

1. Removable LPG tanks can be replaced indoors only if the lift truck is a minimum of 8 m (26 ft) from any open flame, motor vehicles, electrical equipment, or ignition source. Move lift truck to an area where LPG tanks are changed.

- 2.** Turn the shutoff valve clockwise until the valve is completely closed.
- 3.** Run the engine until it stops, then turn the key switch to the **OFF** position if truck is equipped with key switch, or press the Power **ON/OFF** button if truck is equipped with keyless start option.
- 4.** Disconnect the quick-disconnect fittings on the LPG tanks. See **Figure 53**.
- 5.** Unlatch the four latches and open the front covers. Remove LPG tanks from tank brackets. See **Figure 53**.

HYSTER

Maintenance

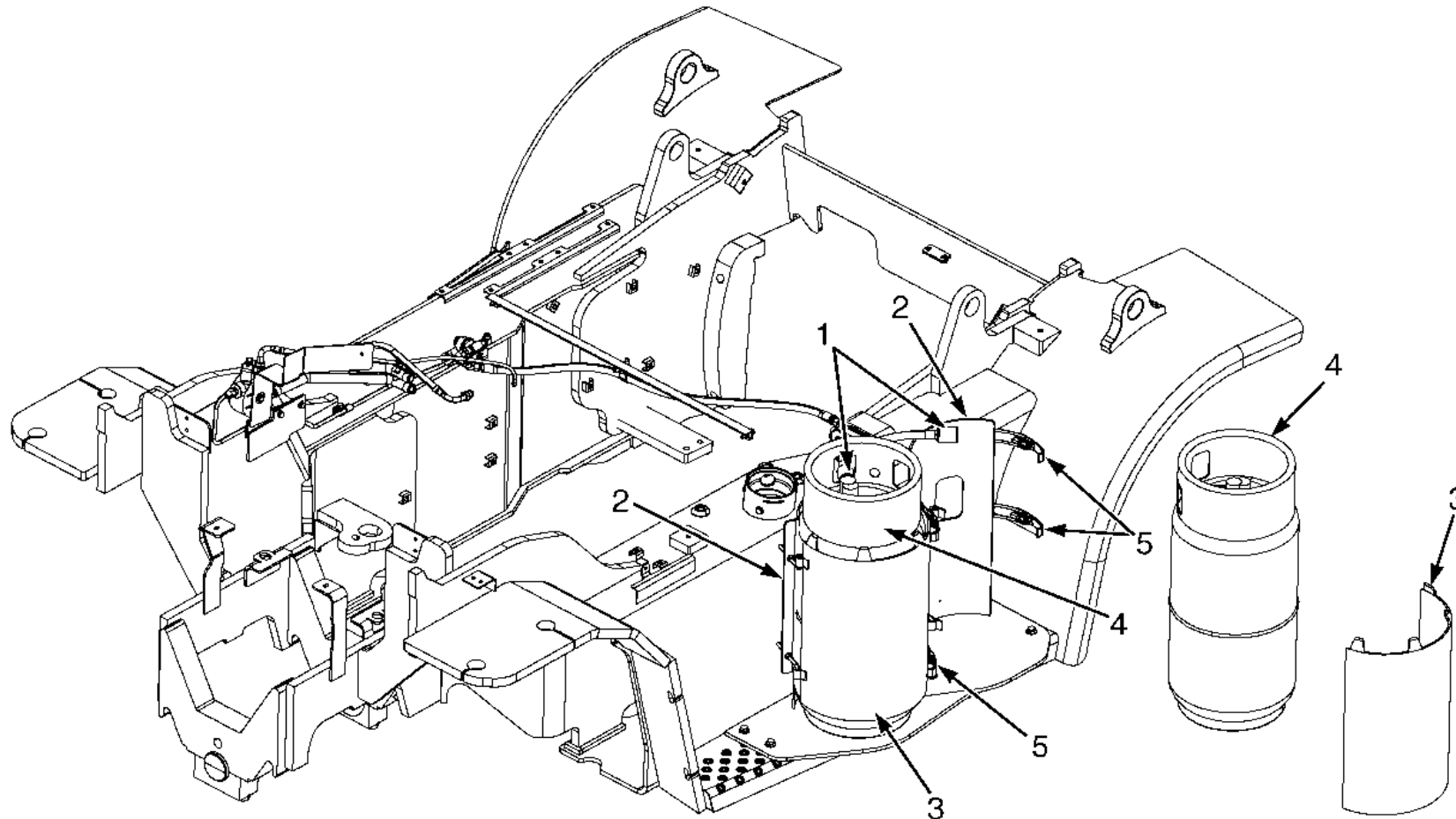

B0190332

Figure 53. LPG Tank and Bracket

1. QUICK DISCONNECT FITTING
2. TANK BRACKET
3. FRONT COVER
4. LPG TANK
5. LATCH



Maintenance

HYSTER

LPG Tank, Fill

WARNING

Read and follow all the refueling precautions and instructions under Liquefied Petroleum Gas (LPG). Removable LPG tanks must be removed from the fork lift before filling.

NOTE: The following instructions are general procedures. There is a variation in equipment for filling LPG tanks. The local authorities that have jurisdiction have specific rules and regulations for filling LPG tanks. Make sure these rules and regulations are available and understood.

1. Check the gauge on tank to make sure it needs filling. During the fill operation, the LPG tank must be in a position so that the liquid level indicator will always be in the vapor space above the liquid level.
2. Open the liquid outlet valve and bypass return valve on the storage tank.
3. Start the pump.
4. Connect the supply hose to the quick disconnect fitting on the LPG tank (see **Figure 53**). If the LPG tank has an auxiliary fill fitting, connect the supply hose to this fitting.

Make sure the correct adapter is used to connect the supply hose to the auxiliary fill fitting.

5. Open the vent valve on the liquid level indicator.
6. Open the fuel valve on the LPG tank.
7. Open the valve on the end of the supply hose.
8. Watch for a discharge from the vent valve on the liquid level indicator. When a cloud of visible vapor appears, the LPG tank is full. Do not fill the LPG tank to more than the maximum level indicated by the liquid level indicator. Immediately close the valve at the end of the supply hose.
9. Close the vent valve on the LPG tank.
10. Close the fuel valve on the LPG tank.
11. Disconnect the hose supply.
12. Stop the pump.
13. Close the liquid outlet and the bypass return valve on the storage tank.

LPG Tank, Install

NOTE: The single or dual LPG tank(s) and bracket(s) are mounted on the right side step weldment of lift truck frame.



HYSTER

Maintenance

The procedures described below are for the dual LPG tank and brackets. Single LPG tank and bracket procedures are similar.

1. Unlatch the four latches and open the front covers. Install each LPG tank into tank brackets. See **Figure 53**.
2. Connect the quick-disconnect fittings on the LPG tanks.
3. Turn the shutoff valves counterclockwise until the valves are completely open.
4. Inspect the fuel system for leaks when the fuel valve is open. There are four methods used to inspect the fuel system for leaks:
 - a. **Sound** - Listen for sound of LPG escaping from a tank fitting or hose connection.
 - b. **Smell** - LPG has a very distinctive odor. If you smell LPG, **DO NOT** start the engine.
 - c. **Soapy Water** - This method is used in conjunction with **Step b** above. If the odor of LPG is present but escaping fuel cannot be heard, apply soapy water to the fittings and observe for bubbles.
 - d. **Frost** - If the amount of LPG escaping is sufficient, frost may appear on the fittings.

Diesel Fuel

WARNING

When fuel is added, keep the funnel or fuel nozzle in contact with the metal of the fuel tank to reduce the possibility of static electric sparks. Clean any spilled fuel.

1. Remove the fuel cap. Make sure the fuel tank is filled with the correct fuel for the type of engine in the lift truck. See **Table 6**. Clean the fuel cap.
2. Replace the fuel cap.

Diesel Exhaust Fluid (DEF)

Refilling DEF Tank

NOTE: DEF must meet ISO 22241, see **Maintenance Schedule** for fluid specifications.

1. Turn key or keyless switch to **OFF** position.
2. Unlock and loosen DEF tank cap. See **Figure 54**.
3. Wipe cap and fill port to remove contaminants.
4. Fully open and remove tank cap.

Maintenance

HYSTER

5. Fill tank with DEF.
6. Install and tighten tank cap. Make sure cap locks.

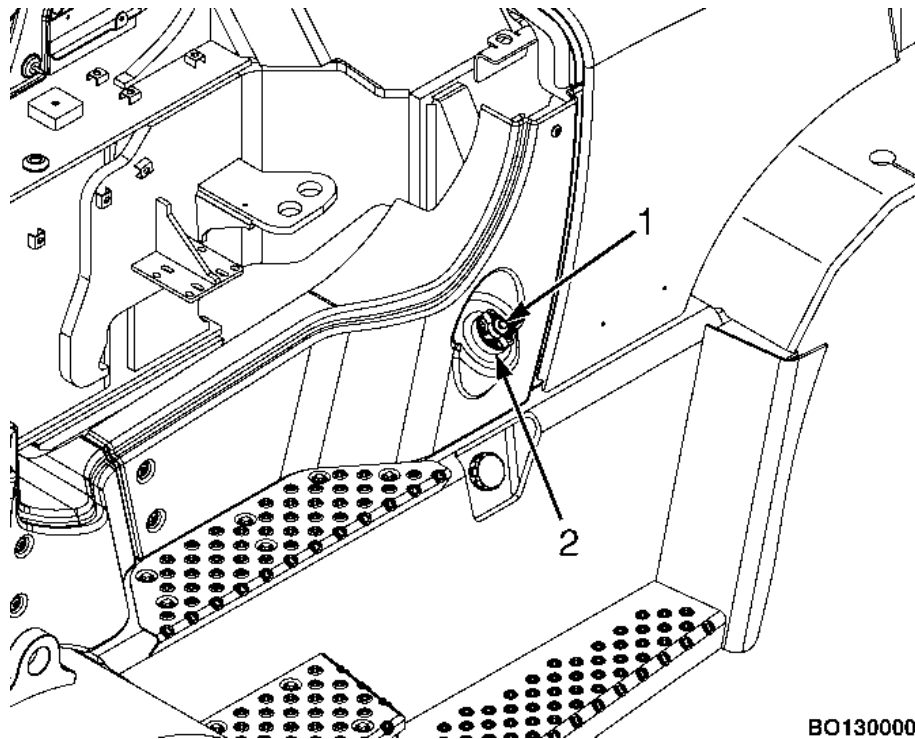

BO130000

1. DEF TANK CAP
2. FILL PORT

Figure 54. DEF Cap

Storage of DEF

NOTE: DEF must meet ISO 22241, see **Maintenance Schedule** for fluid specifications.

Store DEF in a tightly sealed container to avoid evaporation of water content. Container should not be exposed to direct sunlight and storage area should be well ventilated. Ensure storage container is polyethylene or stainless steel, clean, and free of any contaminants such as water, dirt, dust, other chemicals, or oils.

Shelf life of DEF varies depending on storage temperature. See **Table 7**.

Wheels and Tires

General

The lift trucks covered in the **Operating Manual** are equipped with pneumatic tires or solid rubber tires that look like pneumatic tires. These variations in tires also cause a variation in the types of wheels and the disassembly and assembly procedures.



HYSTER

Maintenance

Pneumatic Tire With Tube, Repair

Remove Wheels From Lift Truck

WARNING

A solid rubber tire that is the same shape as a pneumatic tire can be installed on a three-piece or four-piece wheel for a pneumatic tire. **DO NOT** make changes in the parts of the rim if this type of solid rubber tire is installed instead of a pneumatic tire. Changes to the parts of the rim can cause a failure of the wheel and cause an accident.

The type of tire and the tire pressure (pneumatic tires) are shown on the Nameplate. Make sure the Nameplate is correct for the type of tires on the lift truck. If the truck is equipped with bias-ply tires, the ply rating listed on the Nameplate is the minimum ply rating that must be installed. Tires with ply rating greater than or equal to the Nameplate listed ply rating may be acceptable. Check with your dealer whether a specific bias-ply tire is approved for use on Hyster trucks.

WARNING

Wheels must be changed and tires repaired by trained personnel only.

Deflate tire completely before removing the wheel from the lift truck. If dual wheels are used, deflate both tires. Air pressure in the tires can cause the tire and rim parts to explode causing serious injury or death.

Always wear safety glasses.

Never loosen the nuts that hold the inner and outer wheel halves together when there is air pressure in the tire.

CAUTION

Not all makes of radial tires have sufficient side wall strength for successful use on forklift trucks. This can affect stability and ride quality. Check with your dealer whether a specific radial tire is approved for use on Hyster trucks.

1. Put the lift truck on blocks as described in **How to Put a Lift Truck on Blocks** at the beginning of this section.
2. Remove the air from the tire. Remove the valve core to make sure that all of the air is out of the inner tube. Push a



Maintenance

HYSTER

wire through the valve stem to make sure that the valve stem does not have a restriction.

3. Remove the wheel nuts and remove the wheel and tire from the lift truck. Lift truck tires and wheels are heavy.

Remove Tire From Wheel

When disassembling wheels, see **Figure 55**. There are several types of wheels used on this series of lift trucks. See **Tire Removal, Two-Piece Wheel** and **Tire Removal, Three- and Four-Piece Wheels**.

HYSTER

Maintenance

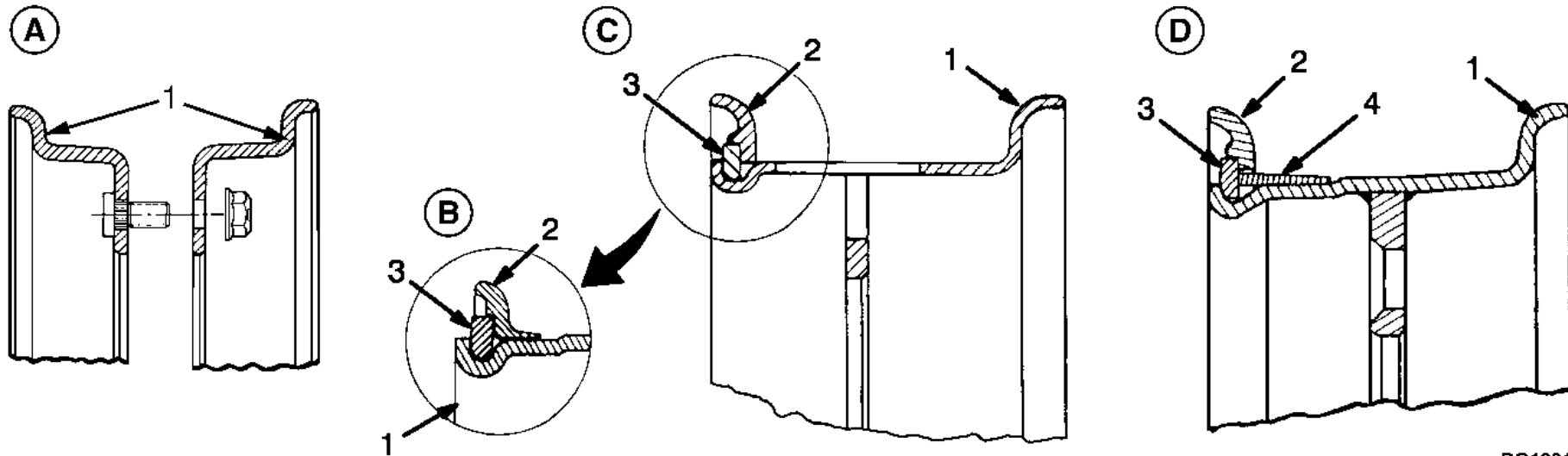

BO190184

- A. TWO-PIECE WHEEL
- B. OPTIONAL RIM ASSEMBLY

- 1. WHEEL RIM
- 2. SIDE FLANGE

- C. THREE-PIECE WHEEL
- D. FOUR-PIECE WHEEL

- 3. LOCK RING
- 4. FLANGE SEAT

Figure 55. Types of Pneumatic Wheels

Maintenance

HYSTER

Tire Removal, Two-Piece Wheel

⚠ WARNING

Make sure all of the air pressure is removed from the tire before a wheel is disassembled. Air pressure in the tires can cause the tire and rim parts to explode causing serious injury or death.

Keep tire tools in firm contact with the wheel parts. If the tool slips, it can move with enough force to cause an injury.

1. Remove the nuts that fasten the wheel rims together.

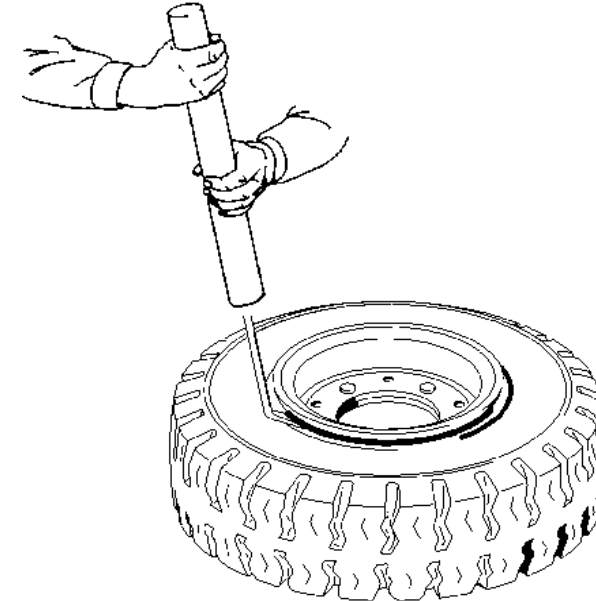
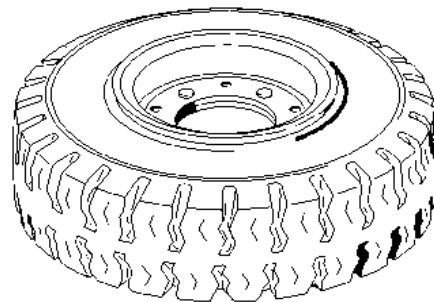

2. Loosen the tire bead from the wheel rim.

3. Remove the wheel rims from tire. Remove the inner tube and flap.

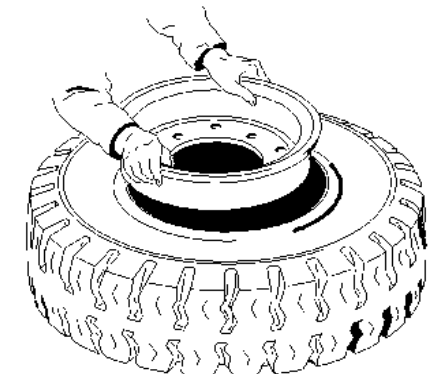



HYSTER

Tire Removal, Three- and Four-Piece Wheels

⚠ WARNING

Make sure all of the air pressure is removed from the tire before a wheel is disassembled. Air pressure in the tires can cause the tire and rim parts to explode causing serious injury or death.

Keep tire tools in firm contact with the wheel parts. If the tool slips, it can move with enough force to cause an injury.

1. Loosen the tire bead from the side flange.

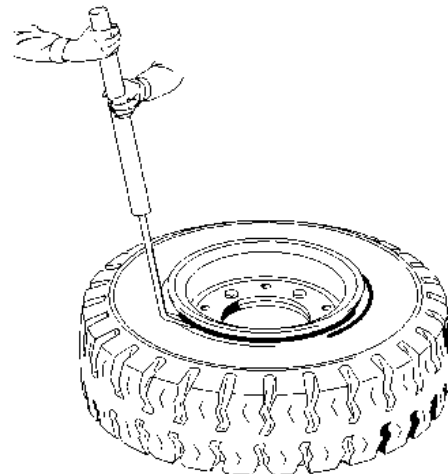

2. Put the tire tool into the slot between the lock ring and wheel rim. Remove the lock ring and side flange. If there is a flange seat, remove it.

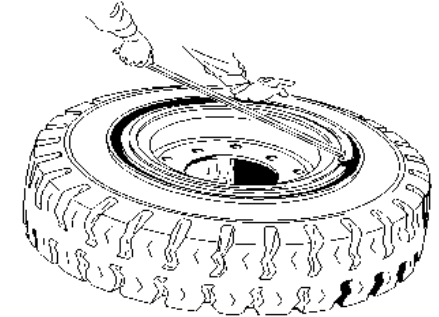

3. Loosen the bead from the other side of the wheel rim. Remove the valve stem from the wheel.

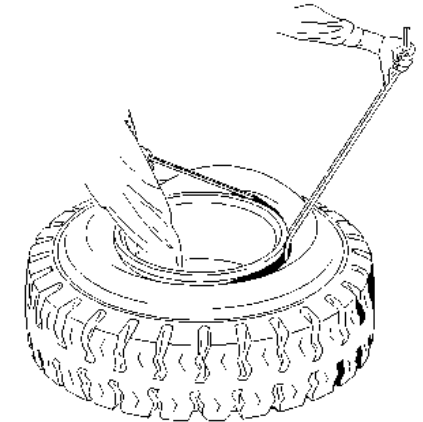

Maintenance



Maintenance

HYSTER

4. Remove the wheel rim from the tire.

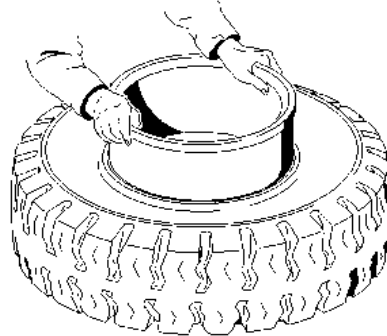

Install Wheel in Tire

⚠ WARNING

Damage to the tire and wheel assembly and injury or death can occur if you do not do the following procedures:

- Clean and inspect all parts of the wheel before installing the tire.
- DO NOT use any damaged or repaired wheel parts.
- Make sure that all parts of the wheel are the correct parts for that wheel assembly.
- DO NOT mix parts between different types or manufacturers of wheels.

- DO NOT mix types of tires, type of tire tread, or wheel assemblies of different manufacturers on any one lift truck.

Do not use a steel hammer on the wheel. Use a rubber, lead, plastic, or brass hammer to put parts together. Make sure that the side ring is in the correct position. The ends of the side ring must not touch. The clearance at the ends of the side ring will be approximately 13 to 25 mm (0.5 to 1.0 in.) after it is installed. If the clearance is wrong, the wrong part has been used.

1. Clean and inspect all parts of the wheel. Paint any parts that have rust or corrosion.
2. Install a new inner tube in the tire. Used tubes and flaps can cause tire failure.

⚠ WARNING

Do not lubricate the tire bead with antifreeze or petroleum-based liquid. Vapors from these liquids can cause an explosion during inflation or use.

3. Apply a rubber lubricant or a soap solution to the tire bead and tube.
4. Install a new tire flap.



HYSTER

Maintenance

⚠ WARNING

Do not lubricate the tire bead with antifreeze or petroleum-based liquid. Vapors from these liquids can cause an explosion during inflation or use.

5. Make sure the rim is the correct size for the tire. Lubricate the part of the wheel that contacts the bead and flap.

6. Install the three-piece or four-piece wheel in the tire as shown in **Tire Installation Three- or Four-Piece Wheel**.

⚠ CAUTION

Do not use pneumatic-shaped, solid tires on two-piece bolt together drive wheels. Spinning may occur.

7. Install the two-piece wheel in the tire as shown in **Tire Installation Two-Piece Wheel**.

Tire Installation Three- or Four-Piece Wheel

⚠ WARNING

Make sure all of the air pressure is removed from the tire before a wheel is disassembled. Air pressure in the tires can cause the tire and rim parts to explode causing serious injury or death.

Keep tire tools in firm contact with the wheel parts. If the tool slips, it can move with enough force to cause an injury.

1. Install the inner tube and the rubber flap in the tire.



2. Install the wheel rim in the tire. Make sure the stem of the inner tube is aligned with the slot in the rim.

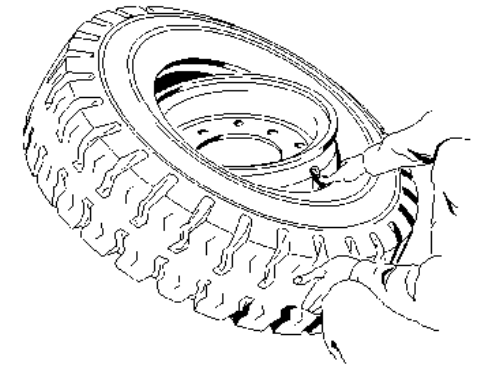



Maintenance

HYSTER

3. Turn over the rim and tire. Put blocks under the rim so that the rim is 8 to 10 cm (3 to 4 in.) above the floor. Install the flange seat (if used) and the lock ring.

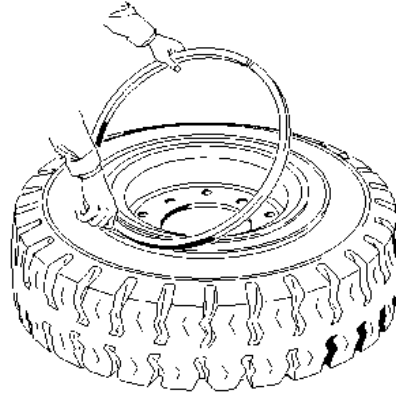

4. Put the lock ring in the correct position on the rim. Add air pressure to the tire as described in **Add Air to Pneumatic Tires With Tube**.

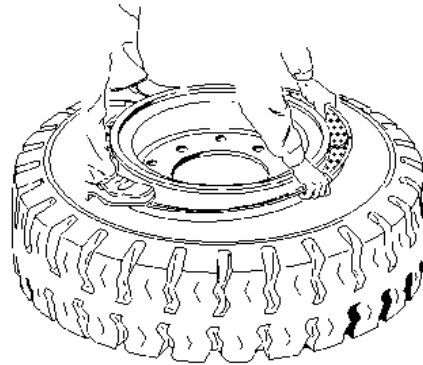

Tire Installation Two-Piece Wheel

CAUTION

Do not use pneumatic-shaped, solid tires on two-piece bolt together drive wheels. Spinning may occur.

1. Install the inner tube and the rubber flap in the tire. Install both halves of the wheel rim in the tire. Make sure the stem of the inner tube is aligned with the slot in the rim.

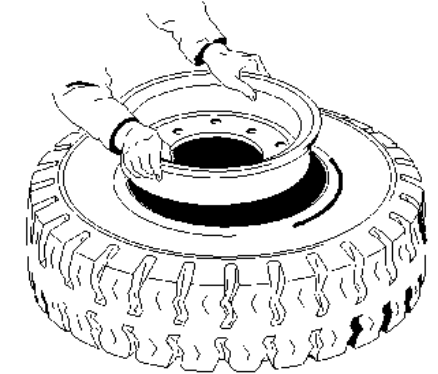

2. Tighten the nuts that hold the rim halves together to 175 N•m (130 lbf ft). Add air pressure to the tire as described in **Add Air to Pneumatic Tires With Tube**.

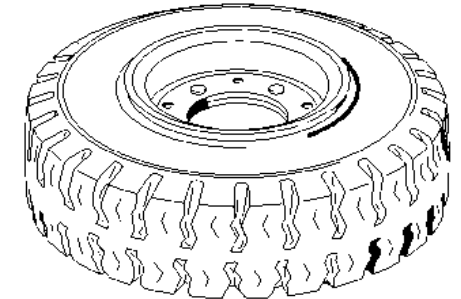

Add Air to Pneumatic Tires With Tube

WARNING

Add air pressure to the tires only in a safety cage. See Figure 56. Inspect the safety cage for damage before use. When air pressure is added, use a chuck that fastens onto the valve stem of the inner tube. Make sure there is enough hose to permit the operation to stand

HYSTER

Maintenance

away from the safety cage when air pressure is added to the tire.

WARNING

Do not sit or stand by the safety cage. Do not use a hammer to try and correct the position of the side flange or lock ring when the tire has air pressure greater than 20 kPa (3 psi) of air pressure to the tire.

1. Put the tire in a safety cage. See **Figure 56**.
2. Add 20 kPa (3 psi) of air pressure to the tire.
3. Check that all wheel parts are correctly installed. Hit the lock ring lightly to make sure that it is in the seat.
4. If installation is correct, add air pressure to the tire to the specified pressure. See Nameplate.
5. Check that all wheel parts are correctly installed. If installation is not correct, remove all of the air pressure from the tire. Remove the valve core to make sure all of the air pressure has been removed and then make adjustments. The clearance at the ends of the lock ring will be approximately 13 to 25 mm (0.5 to 1.0 in.) when the tire has the correct air pressure.

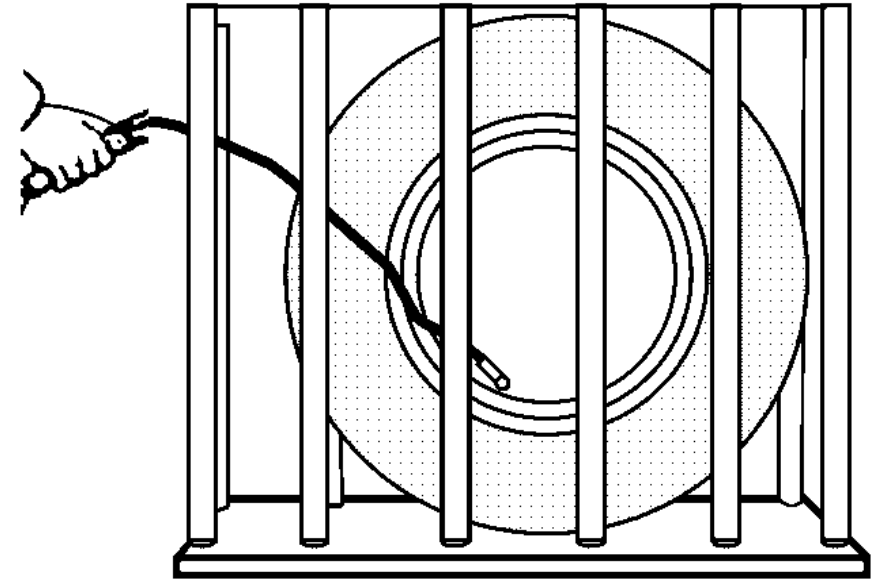

BO260046

Figure 56. Add Air to Tires With Tube

Install the Wheels

Install the wheel on the hub. Tighten the nuts in a cross pattern to torque value of 610 to 680 N•m (450 to 500 lbf ft) for both the drive wheel and steer wheel nuts. If the wheels are the two-piece rims, make sure the nuts that fasten the rim halves together are toward the brake drum when they are installed.



Maintenance

HYSTER

Pneumatic Tubeless Tire, Repair

Remove Tire From Lift Truck

WARNING

Wheels must be changed and tires repaired by trained personnel only.

Deflate tire completely before removing the wheel from the lift truck. If dual wheels are used, deflate both tires. Air pressure in the tires can cause the tire and rim parts to explode causing serious injury or death.

Always wear safety glasses.

Never loosen the nuts that hold the inner and outer wheels halves together when there is air pressure in the tire.

The Tubeless Bead Seal (TBS) enables tubeless tires to be used on wheel rims that were designed to be used with a tube.

The main component of the TBS is a special rubber ring that fits inside the tire between the tire beads to ensure the airtightness of the existing wheel and the tubeless tire assembly. See **Figure 57**.

1. Put the lift truck on blocks as described in **How to Put a Lift Truck on Blocks** at the beginning of this section.
2. Remove the valve cap and core to remove all air from the tire.
3. Remove the wheel nuts and remove the wheel and tire from the lift truck. Lift truck tires and wheels are heavy.

Remove Tire From Wheel

WARNING

Make sure all of the air pressure is removed from the tire before a wheel is disassembled. Air pressure in the tires can cause the tire and rim parts to explode causing serious injury or death.

Keep tire tools in firm contact with the wheel parts. If the tool slips, it can move with enough force to cause an injury.

NOTE: There are several types of wheels used on these lift trucks. When disassembling wheels, see **Figure 56**.

HYSTER

1. If wheel rim is a three- or four-piece rim, turn the valve 1/4 turn and remove valve from wheel.

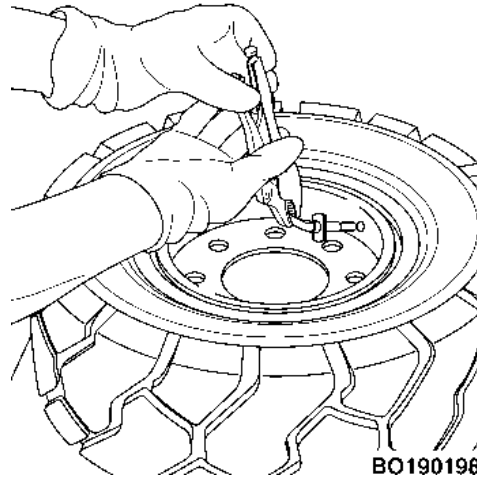

2. Put wheel and tire assembly on the press. Position the feet of the press on the loose flange. Push press down on loose flange to expose the locking ring.

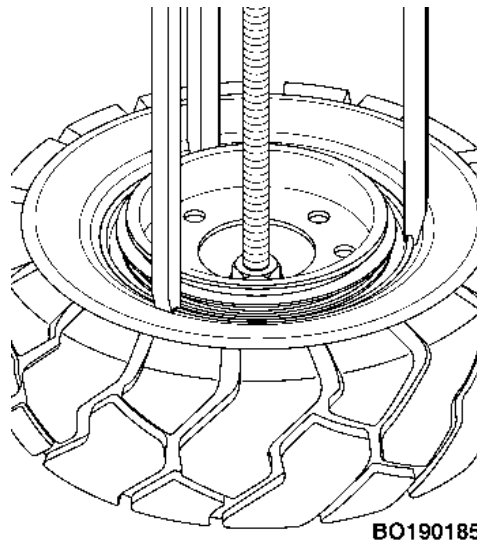

3. Remove the loose flange locking ring and the advance band (four-piece wheel only) using a tire tool.

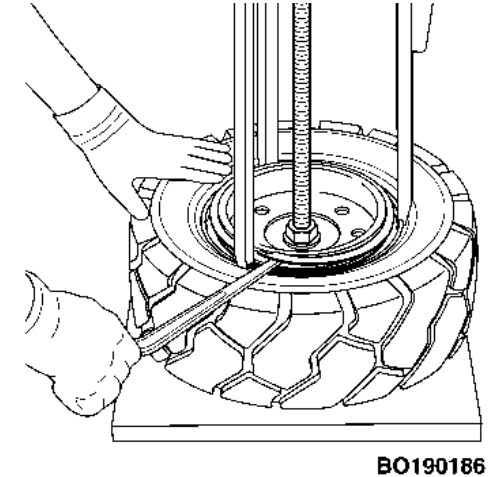

4. Remove the press and remove the loose flange locking ring and the advance band (four-piece wheel only) from the tire and wheel assembly.

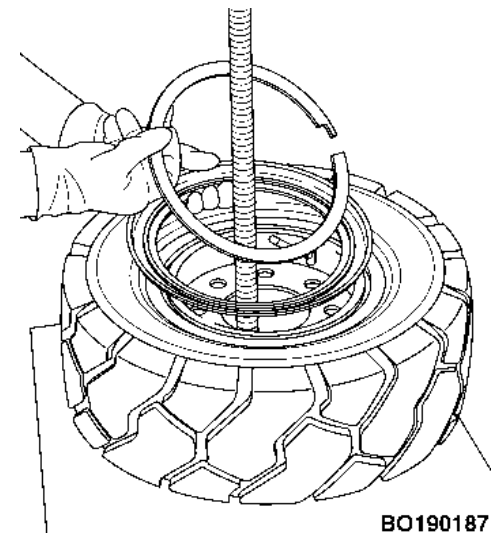

Maintenance

Maintenance

HYSTER

5. Push the TBS toward the inside of the tire to remove it.

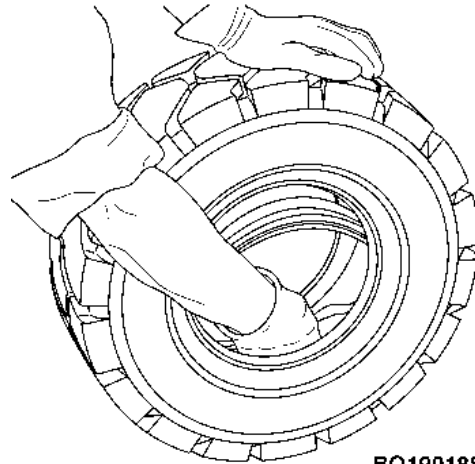

Install Tire on Wheel

WARNING

Damage to the tire and wheel assembly and injury or death can occur if you do not do the following procedures:

- Clean and inspect all parts of the wheel before installing the tire.
- **DO NOT** use any damaged or repaired wheel parts.
- Make sure that all parts of the wheel are the correct parts for that wheel assembly.

- **DO NOT** mix parts between different types or manufacturers of wheels.
- **DO NOT** mix types of tires, type of tire tread, or wheel assemblies of different manufacturers on any one lift truck.

WARNING

Do not use a steel hammer on the wheel. Use a rubber, lead, plastic, or brass hammer to put parts together.

WARNING

Do not lubricate the tire bead with antifreeze or petroleum-based liquid. Vapors from these liquids can cause an explosion during inflation or use.



HYSTER

1. Clean interior and exterior bead area of the tire. Lubricate tire beads and the inside of the tire, up to the tire shoulders. Apply lubricant to entire underside of the TBS.

NOTE: If the wheel rim width is less than six inches, the TBS will contain one valve hole to accommodate the needle valve. If the wheel rim width is greater than six inches, the TBS will have two holes for the needle valve.

One hole is centrally located and the other is offset, to ensure the correct positioning of the valve in the valve slot. The valve hole that is not used should be sealed with a small plastic plug.

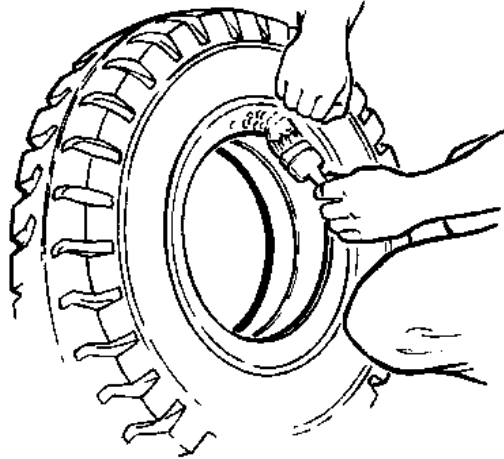

2. Apply lubricant to the needle valve and the valve hole that will be used (see **NOTE** in **Step 1**), by inserting and removing the lubricated valve several times. If a three- or four-piece wheel is being used, remove the valve. If a two-piece wheel is being used, leave valve in valve hole.

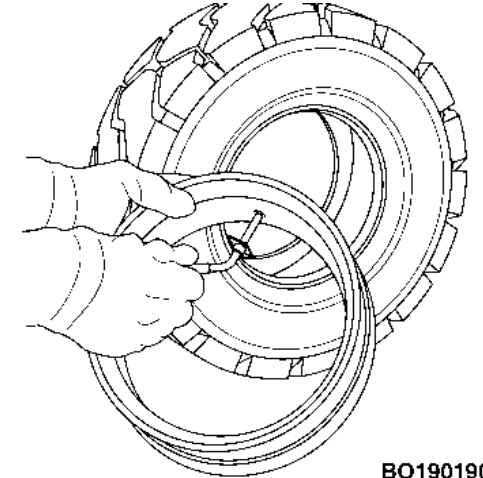

BO190190

If the TBS has two valve holes, lubricate the plastic plug and insert into valve hole that will not be used.

3. Place the TBS inside the tire, making sure that the wings of the TBS are not folded over. Make a mark on the tire to note the position of the valve hole in the TBS.

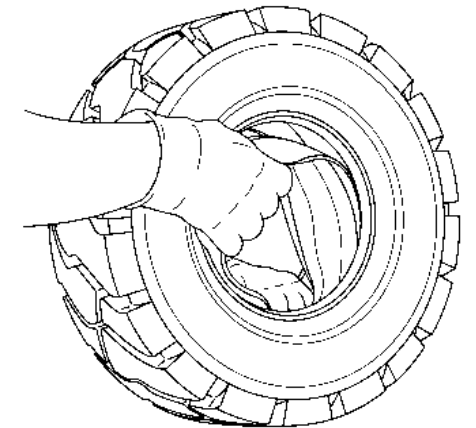

BO190191

Maintenance

Maintenance

4. Apply lubricant to the rim. If a four-piece wheel is being used, lubricate the advance band. Slide the tire and TBS onto the wheel.

Line up the valve hole in the TBS with the valve slot in the wheel. Lubricate and insert the valve into the valve hole. Make sure it is fully inserted.

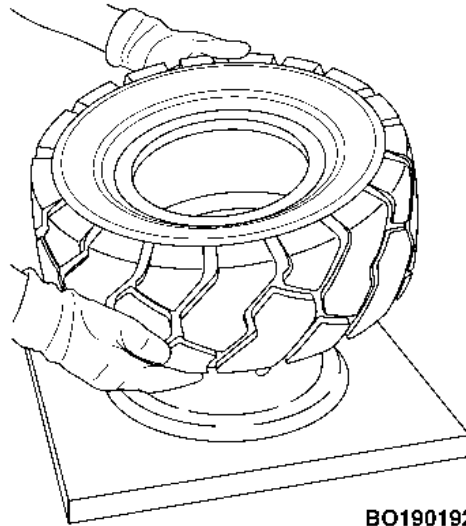

5. Place the wheel and tire assembly on a flat surface. Turn the valve a 1/4 turn to lock the collar under the edges of the rim valve slot.

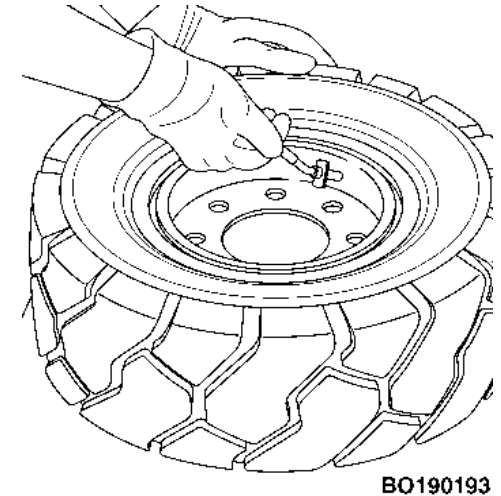

6. Raise the tire and position the base and threaded stem of the press through the hole in the center of the wheel. Insert in wheel assembly, the following parts:

- Advance band (four-piece wheel only)
- Loose flange
- Locking ring

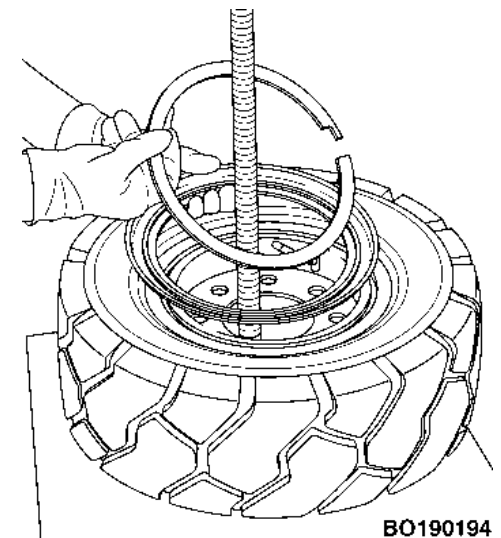

HYSTER

HYSTER

7. Position the advance band. Ensure that it does not go in too far and damage the valve. Position the arms of the press onto the loose flange.

Push down on press to depress the tire beads until the locking ring groove is fully exposed.

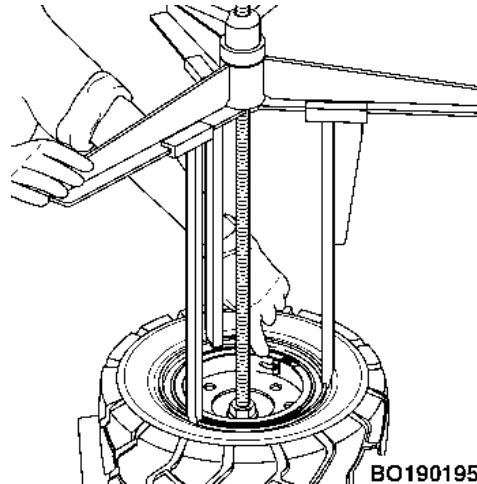

8. Insert tire tool into the locking ring groove, and a vise grip on other end. Remove vise grip. Release the press and check that all component parts are correctly positioned. Replace the valve core.

9. Inflate tire to 103 kPa (15 psi). Tap wheel with a mallet to ensure all components are correctly sealed.

Remove the press from wheel and tire assembly.

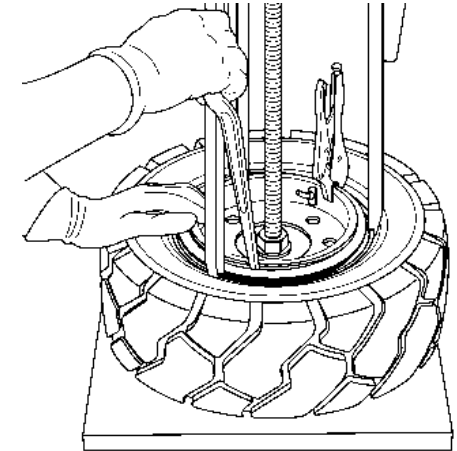

Add Air to Pneumatic Tubeless Tire

WARNING

Add air pressure to the tires only in a safety cage. See Figure 57. Inspect the safety cage for damage before use. When air pressure is added, use a chuck that fastens onto the valve stem. Make sure there is enough hose to permit the operator to stand away from the safety cage when air pressure is added to the tire. Do not sit or stand by the safety cage.

1. Put tire in safety cage. See Figure 57.

Maintenance

Maintenance

HYSTER

2. Add air to tire to the recommended pressure that is shown on the Nameplate. Install valve cap to ensure air stays in the tire.

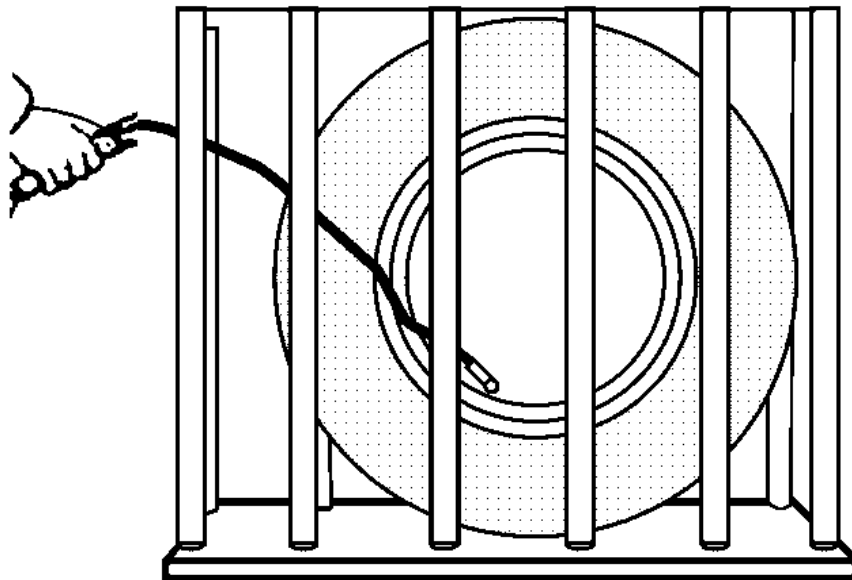

BO260046

Figure 57. Add Air to Tubeless Tire

Install the Wheels

Install the wheel on the hub. Tighten the nuts in a cross pattern to torque value of 610 to 680 N•m (450 to 500 lbf ft) for both drive wheel and steer wheel nuts. If the wheels are

the two-piece rims, make sure the nuts that fasten the rim halves together are toward the brake drum when they are installed.

Solid Rubber Tires on Pneumatic Wheels, Change

⚠ WARNING

Wheels must be changed and tires repaired by trained personnel only.

Always wear safety glasses.

1. Put the lift truck on blocks as described in **How to Put a Lift Truck on Blocks** at the beginning of this section.
2. Remove the wheel nuts and remove the wheel and tire from the lift truck. Lift truck tires and wheels are heavy.

Remove Tire From Wheel

⚠ WARNING

Keep tire tools in firm contact with the wheel. If the tool slips, it can move with enough force to cause serious injury.

HYSTER

Maintenance

NOTE: When disassembling wheels, see **Figure 55**. There are several types of wheels used on these series of lift trucks.

1. Put the wheel rim on the bed of the press. Put the cage in position on the tire. Use press to push the tire away from the side flange.

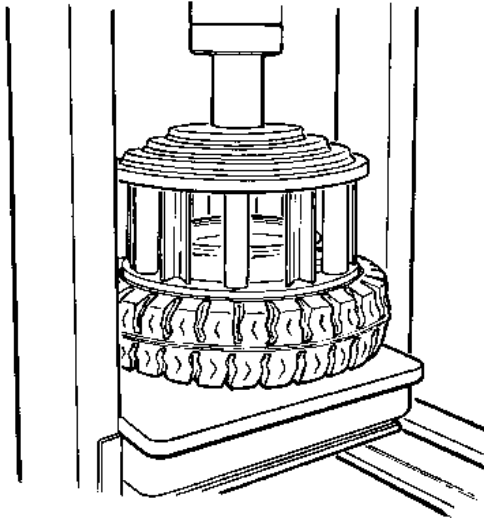

2. Put the tire tool into the slot between the lock ring and the wheel rim. Remove the lock ring and side flange.

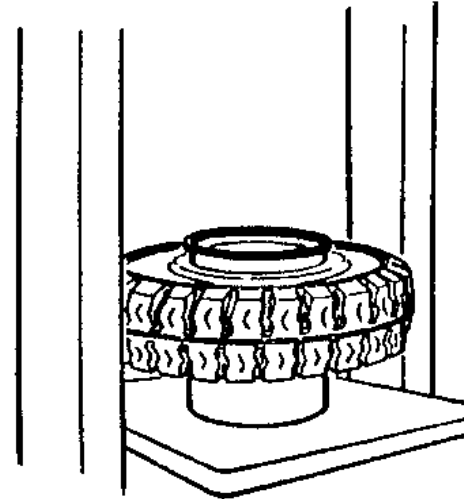
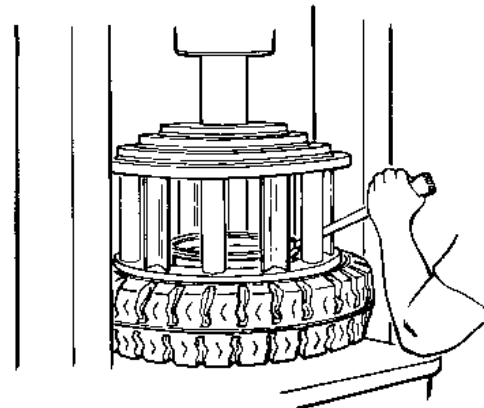

3. Turn the tire over. Put a support under the wheel rim. Make sure the wheel rim is at least 150 to 200 mm (6 to 8 in.) from the bed of the press.

Maintenance

HYSTER

4. Put the cage in position on the tire. Use the press to push the tire from the wheel rim.

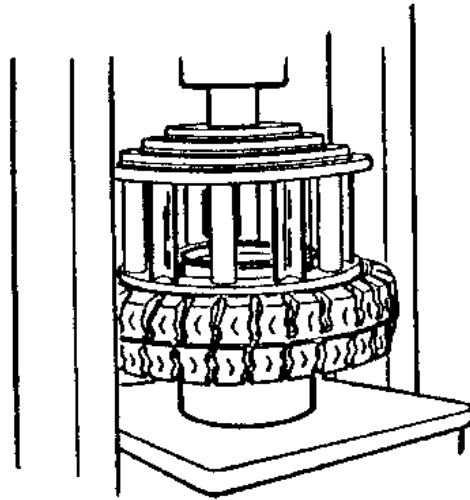

Install Tire on Wheel

WARNING

Damage to tire and wheel assembly and injury or death can occur if you do not do the following procedures:

- Clean and inspect all parts of the wheel before installing the tire.
- **DO NOT** use any damaged or repaired wheel parts.
- Make sure that all parts of the wheel are the correct parts for the wheel assembly.

- **DO NOT** mix parts between different types or manufacturers of wheels.
- **DO NOT** mix type of tires, type of tire tread, or wheel assemblies of different manufacturers on any one lift truck.

Do not use a steel hammer on the wheel. Use a rubber, lead, plastic, or brass hammer to put parts together. Make sure that the lock ring is in the correct position. The ends of the lock ring must not touch. The clearance at the ends of the side ring will be approximately 13 to 25 mm (0.5 to 1.0 in.) after it is installed. If the clearance is wrong, the wrong part has been used.

NOTE: When disassembling wheels, see **Figure 55**. There are several types of wheels used on these series of lift trucks.

CAUTION

Too much lubricant can cause the tire to slide and move around the wheel rim.

HYSTER

Maintenance

1. Lubricate the wheel rim and the inner surface of the tire with tire lubricant or soap.

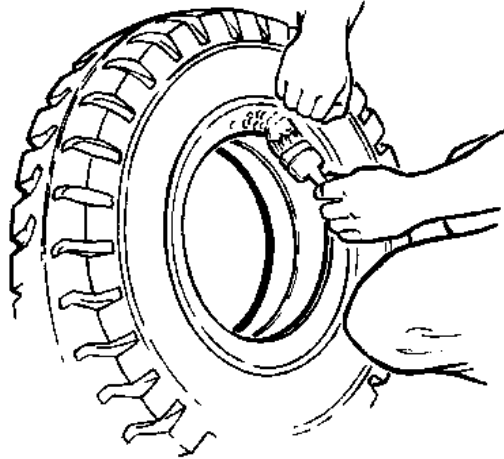

2. Put the wheel rim on the bed of the press. Put the tire over the wheel rim. Put the cage in position on the tire. Use press to install the tire on the wheel rim.

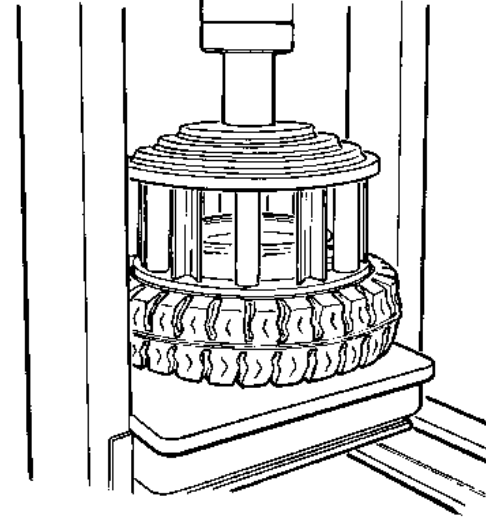
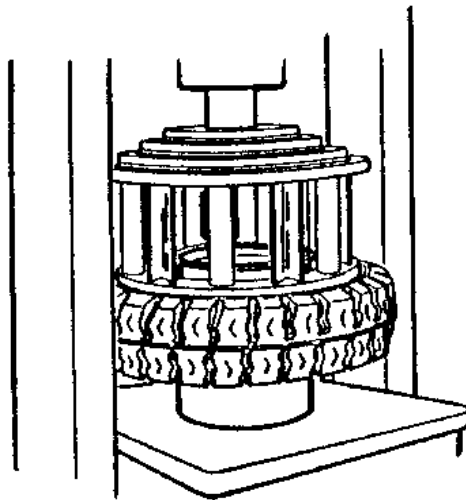

3. Remove the cage and put the flange seat (if used), the side ring, and the lock ring in position on the wheel rim. Install the cage on the tire. Use the press to push the tire onto the wheel rim so that the side flange and lock ring can be installed.

4. While the cage is holding the tire on the wheel rim, install the lock ring. Use a tire tool to make sure the lock ring is in the correct position.

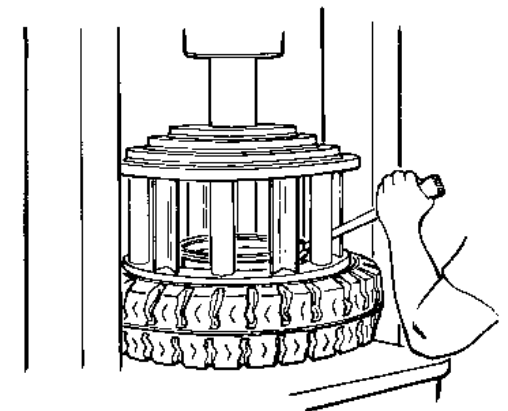

Maintenance

HYSTER

Dual Drive Wheels, Install

NOTE: Some lift trucks have dual drive wheels. The following procedures describe the steps to install the dual sets of wheels.

1. Install inner wheel on hub. If the wheels are the two-piece rims, make sure nuts that fasten rim halves together are toward brake drum when they are installed.

2. Install wheel adapter spacers on the inner wheel studs and tighten spacers to 100 to 125 N•m (74 to 92 lbf ft). Install the dual hub assembly and inner wheel nuts on the spacers and tighten the wheel nuts to 610 to 680 N•m (450 to 500 lbf ft). See **Figure 58**.

3. Install outer wheel on dual hub assembly. Tighten nuts to a torque value of 610 to 680 N•m (450 to 500 lbf ft). If the wheels are the two-piece rims, make sure nuts that fasten rim halves together are toward brake drum when they are installed.

4. Install the valve extension bracket and tighten the attaching nut to 8 N•m (70 lbf in). Install the valve extension hose into the bracket. See **Figure 58**.

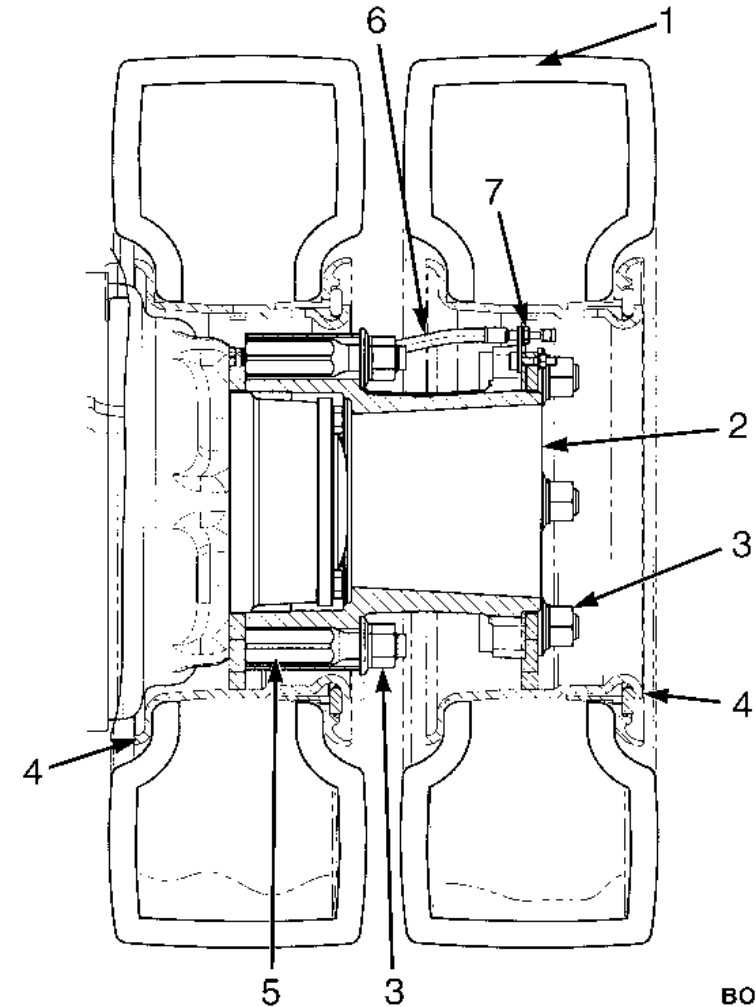

BO190333

Figure 58. Dual Drive Wheels Installation



HYSTER

Maintenance

Legend for Figure 58

1. TIRE
2. DUAL HUB ASSEMBLY
3. WHEEL NUT
4. WHEEL
5. WHEEL ADAPTER SPACER
6. VALVE EXTENSION
7. BRACKET

Snap-On-Tire, Change

WARNING

Wheels must be changed and tires repaired by trained personnel only.

Always wear safety glasses.

1. Put the lift truck on blocks as described in **How to Put a Lift Truck on Blocks** at the beginning of this section.
2. Remove the wheel nuts and remove the wheel and tire from the lift truck. Lift truck tires and wheels are heavy.

NOTE: See **Figure 59** when you disassemble the wheels. There are several types of wheels used on these series of lift trucks.

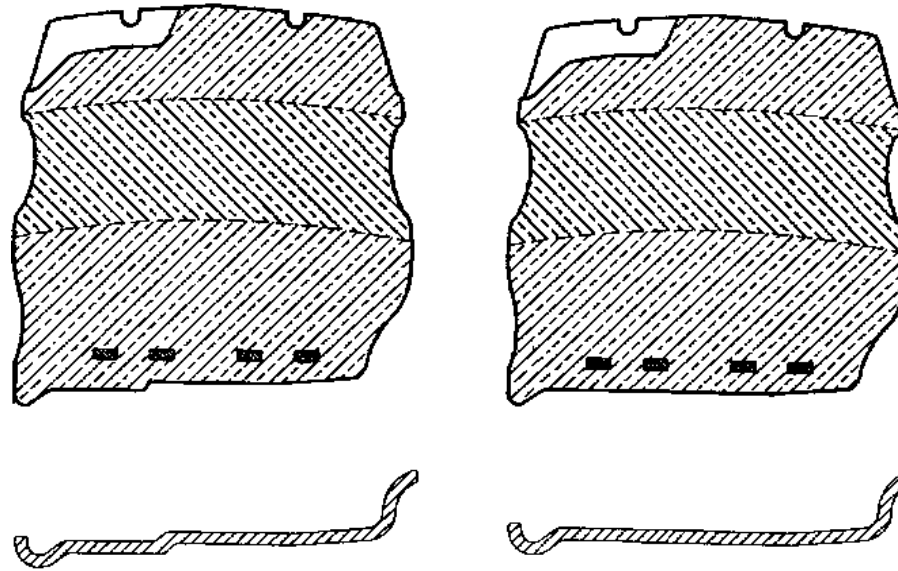

HO210000

Figure 59. Snap-On-Tires and Rim Configurations

HYSTER

Maintenance

Remove Snap-On-Tire, Solid Tire From Wheel

WARNING

Keep tire tools in firm contact with the wheel. If the tool slips, it can move with enough force to cause serious injury.

1. Put a support under the wheel rim. Make sure the wheel rim is at least 150 to 200 mm (6 to 8 in.) from the bed of the press.

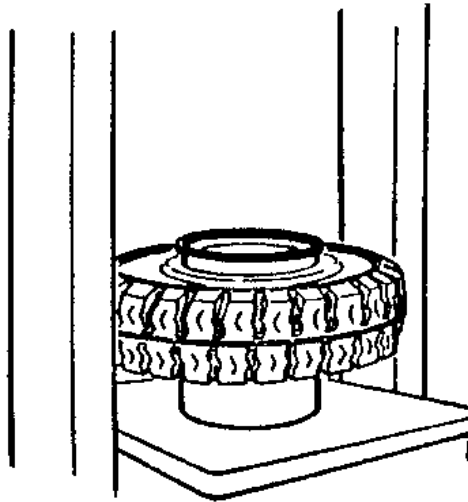

2. Put the cage in position on the tire. Use the press to push the tire from the wheel rim.

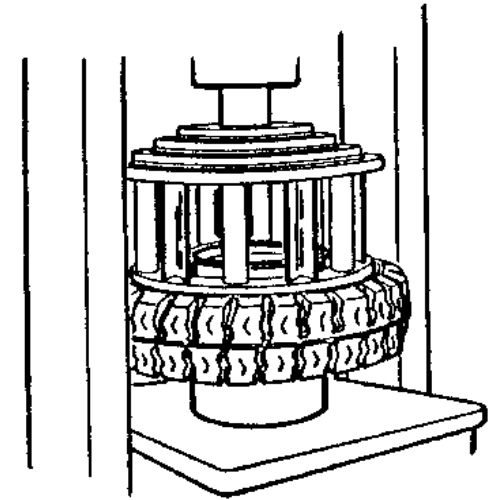

Install Snap-On-Tire, Solid Tire on Wheel

NOTE: When wheels are disassembled, see **Figure 59**. There are several types of wheels used on this series of lift trucks.

WARNING

Failure to follow these procedures will cause damage to the tire and wheel assembly and can cause injury.

- Clean and inspect all parts of the wheel before installing the tire.
- **DO NOT** use any damaged or repaired wheel parts.

Maintenance

- Make sure that all parts of the wheel are the correct parts for the wheel assembly.
- **DO NOT** mix parts between different types or manufacturers of wheels.
- **DO NOT** mix type of tires, type of tire tread, or wheel assemblies of different manufacturers on any one lift truck.

CAUTION

Too much lubricant can cause the tire to slide and move around the wheel rim.

1. Lubricate the wheel rim and the inner surface of the tire with tire lubricant.

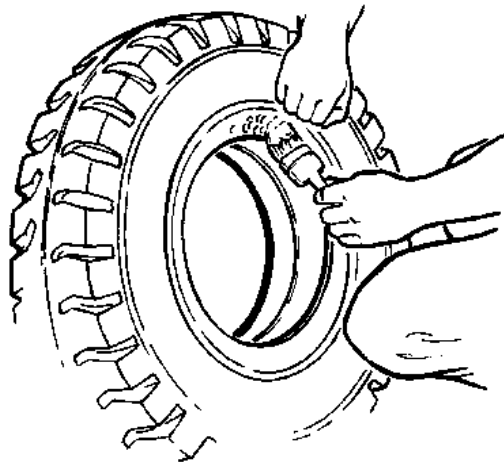

2. Put the wheel rim on the bed of the press. Put the tire over the wheel rim. Put the cage in position on the tire. Use the press to install the tire on the wheel rim.

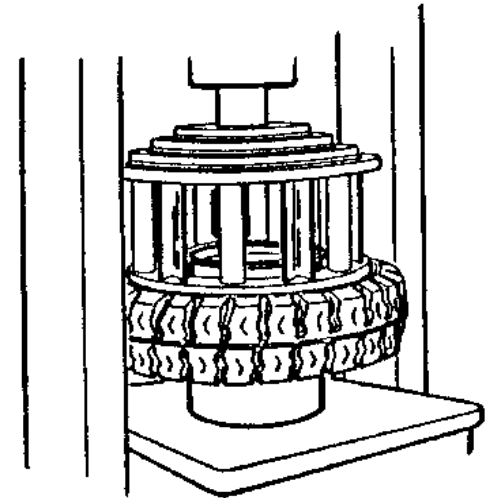

HYSTER

Jump-Starting the Lift Truck

Jump-Starting Using a Battery Charger

CAUTION

DO NOT try to start the engine by pushing or towing the lift truck. Damage to the transmission can occur if engine is started by pushing or towing lift truck.

If the battery becomes discharged and requires a booster battery to start the engine, follow these procedures carefully when connecting the jumper cables:



HYSTER

Maintenance

1. Disconnect the negative battery terminal of the lift truck being started.
2. Always connect positive jumper cable to positive terminal of discharged battery and negative jumper cable to negative terminal.
3. Always connect jumper cable, that is the ground cables, last.
4. Always connect jumper cables to discharged battery before connecting them to booster battery.

Jump-Starting Using Another Lift Truck

WARNING

To prevent possible arcing between the two lift trucks, make sure that the lift trucks are not touching.

CAUTION

DO NOT try to start the engine by pushing or towing the lift truck. Damage to the transmission can occur if engine is started by pushing or towing lift truck.

1. Always connect positive jumper cable to positive terminal of discharged battery and negative jumper cable to negative terminal.

2. Always connect jumper cable, that is the ground cable, last.
3. Always connect jumper cables to discharged lift truck battery before connecting them to the fully charged lift truck battery.

Operating Procedures for a New or Rebuilt Engine

A new or rebuilt engine must be operated under special conditions during the first 50 hours. These special conditions prevent damage to the engine until the new parts can wear and adjust to fit each other.

1. Make sure the fluid levels of oil and coolant are correct.
2. Start and run the engine at approximately one-half throttle for 30 minutes for the first operation. Check the gauges and indicators for the correct operation during this first operating period. Check for leaks.
3. If the work conditions are slow and the loads are less than 50% of the truck capacity, a simulated work condition must be used during the first four hours of operation. Operate the lift truck with a minimum load of 75% capacity. Operate the engine through cycles from idle to full throttle



Maintenance

HYSTER

and back to idle. Avoid long periods of high engine speeds with a light load during the first 50 hours of operation. High engine speeds with a light load can cause damage to the cylinders in the engine.

Changes to the Overhead Guard

WARNING

Do not operate the lift truck without the overhead guard correctly fastened to the lift truck.

Do not make changes to the overhead guard by welding. Changes that are made by welding, or by drilling holes that are too big in the wrong location, can reduce the strength of the overhead guard.

See your dealer for Hyster lift trucks BEFORE performing any changes to the overhead guard.

How to Put Internal Combustion Engine (ICE) Trucks in Storage

It is important to store your lift truck properly to protect it. The main areas of concern are engines, hydraulic components, and truck batteries. The length of storage time and the storage location determines what procedures you should follow.

Before placing any lift truck in storage, you must choose an area that is clean, dry, and free from airborne contaminants. For safety and increased usable floor area, remove the forks and tag them with the lift truck serial number. For best protection, operate your internal combustion engine lift truck for a short period each month.

The following storage procedures are for conditions and temperatures above 0 °C (32 °F). Adjust these procedures for local conditions and any changes in conditions during storage. The preparations necessary for storage are also determined from the following conditions:

- Short-term storage is from one to six months. Long-term storage is over six months.
- Storage Location. A lift truck stored indoors will not require as much external protection as a lift truck stored outdoors.

Short-Term Storage

Perform the following steps to prepare your lift truck for storage from one to six months:

1. Check lubricant and fluid levels. Completely fill the fuel tank. Make sure the coolant mixture will protect cooling system and engine to lowest temperature expected during



HYSTER

Maintenance

storage. Make sure all caps and dipsticks are installed correctly.

2. Fully lower the mast. If lift truck is equipped with forks, tilt mast **FORWARD** until the tips of the forks touch the floor. Apply a thin coat of fresh, high grade SAE 30 or 40 weight engine oil to the exposed cylinder rods. If the forks are removed, tilt mast **BACKWARD** until cylinders are completely retracted. This protects the cylinder rods.

3. Check that all switches and accessories are in the **OFF** position.

4. Activate each control lever to relieve hydraulic pressure.

5. Install blocks, front and rear, at the drive wheels. If the lift truck must be left on an incline, put blocks on the downhill side of all wheels so that the lift truck cannot move. **DO NOT USE THE PARKING BRAKE.**

6. Disconnect the battery cables from the battery. Apply a protective coating to the cable connectors and battery terminals to prevent corrosion.

7. Check the tire pressure, if applicable. Make sure the tires have the correct pressure (see the Nameplate.)

8. Clean the lift truck and engine compartment to prevent corrosion.

9. If the lift truck is not stored indoors, put a cover over the lift truck to prevent damage from the weather. In wet conditions, a cover will not prevent corrosion to the lift truck.

Long-Term Storage

Do the following steps to prepare the lift truck for storage for 6 months or longer:

1. Complete all short-term storage procedures.

2. Wrap or cover all exterior lights, radiator grill, and air vents with a moisture barrier cover. Use tape to hold the covers in place.

3. Remove the battery or batteries from the lift truck. Store the battery or batteries in an approved space. Be sure to follow local regulations. Batteries that are stored for long periods can become damaged. Either keep batteries in service or follow the battery storage procedures below.

4. Spray exterior surfaces and frame with preservative coating.



Maintenance

HYSTER

While the Lift Truck is in Storage

Each month make a visual inspection for leaks or signs of deterioration. Take corrective action immediately. Check the fluid level in engine, radiator, hydraulic tank, and brake master cylinder.

NOTE: Do not shut down an engine before it reaches operating temperature.

Each month set the park brake, start engine, and run until normal operating temperature is reached. This will coat the internal engine components with a film of oil and rid the engine of built-up condensation.

Each month all hydraulic cylinders must be cycled several times to keep the seals active and to coat the interior walls with oil. Actuate each cylinder, in both directions, until it reaches the stops.

Return lift truck to its storage state for another month.

How to Put Batteries in Storage

Batteries are to be placed on a wooden pallet and stored in a dry, moderately cool area.

Lead acid batteries will slowly "self-discharge" over a period of time due to their chemical makeup. If the self-discharge is left uncontrolled, excessive sulphation can occur which is difficult to reduce and can damage the anodes. A discharged battery with a specific gravity of 1.000 will freeze at $-7.8\text{ }^{\circ}\text{C}$ ($18\text{ }^{\circ}\text{F}$) A fully-charged battery with a specific gravity of 1.280 will freeze at $-66\text{ }^{\circ}\text{C}$ ($-87\text{ }^{\circ}\text{F}$).

This "self-discharge" is due to a chemical reaction; therefore, that chemical reaction can be accelerated by heat resulting in more rapid "self-discharge." The rate of discharge can amount to an average of about 0.001 point drop in specific gravity per day.

The following procedure can be followed when placing a battery in storage or when not in operation for more than 30 days.

1. Give an equalizing charge prior to placing new batteries in storage. Used batteries are to be fully charged, then allowed to balance for approximately three more hours.
2. Neutralize and clean the battery. Clean with a solution of 100 grams (3.5 oz) of sodium bicarbonate (baking soda) per 1 liter (0.25 gal) of water.
3. Store in a cool, dry location.



HYSTER

Maintenance

4. Check each cell in the battery at least once every 30 days and boost charge when specific gravity falls below 1.240 Hg.

5. Protect batteries from ambient contamination.

If a greasy film forms on the top of a battery, this is acid and must be neutralized with the solution described above.

Putting a Stored Lift Truck Back Into Service

1. Remove all tape, covers, and preservation materials.
2. Check the lift truck for damage and missing components. Repair damage and/or replace missing components.

NOTE: If the lift truck has been stored longer than one year, all lubricants and fluids must be drained and replaced. See the **Periodic Maintenance** section of your service manual for the procedures.

3. Clean the battery cables and terminals. Check the battery voltage. If the voltage is not correct, charge battery. Connect battery cables to battery.

4. When a lift truck is to be put into service after storage, it must be given the 500-hour inspection shown in the **Recommended Schedule of Maintenance**.

How to Move a Lift Truck on a Transport

Before the lift truck is moved on a transport, check the selected route to make sure there is enough clearance for the lift truck as loaded on the transport vehicle. Bridges, overpasses, powerlines, and natural barriers can prevent clearance. Removal of the mast can be necessary.

If a trailer is the method of transportation, use blocks in front and back of the trailer tires to prevent movement of the trailer when the lift truck is loaded and unloaded. If a loading ramp is used, make sure that the ramp is the correct design and capacity.

If the lift truck is equipped with lifting eyes, use a crane to load and unload the lift truck from the transport. If the truck is not equipped with approved lifting eyes, do not lift the truck by attaching a lifting device to any other part of the lift truck for the purposes of loading or unloading.

Loading

WARNING

The straps or chains used to fasten the lift truck to the transport must be directly connected to the lift truck frame or to a component (drive axle, tow pin) that is



Maintenance

HYSTER

solidly attached to the frame. Do not fasten a strap or chain to the mast or any attachment to hold the lift truck on the transport.



CAUTION

Make sure that any straps or chains used to fasten the lift truck to the transport do not contact any tubes, hoses, hydraulic cylinders, or other parts of the truck that are easily damaged.

If components and attachments must be removed for transport of the lift truck, see the **Service Manual** for removal procedures.

The operator must never leave a lift truck in a condition so that it can cause damage and injury. When the lift truck is loaded on the transport, do the following operations:

1. Apply the parking brake.
2. If the mast is mounted on the lift truck, fully lower the forks or carriage. Tilt the mast **FORWARD** until the tips of the forks touch the surface.
3. Put the direction control lever for the powershift transmission in **NEUTRAL** (N). If the lift truck has a manual

transmission, leave the gears of the transmission engaged. DO NOT leave a manual transmission in **NEUTRAL** (N).

4. Turn the key switch to **OFF** to stop the engine, if truck is equipped with a key switch, or press the Power **ON/OFF** button, if truck is equipped with a keyless option. Check that all switches and accessories are turned **OFF**.

5. Put blocks in front and back of the lift truck tires to prevent any movement of the lift truck. Make sure the blocks are attached to the load surface.

6. Tie the lift truck to the transport vehicle using straps or chains. The straps or chains must be directly connected to the lift truck frame or to a component such as the drive axle, tow pin in the counterweight, or the two center grill bars in the counterweight for lift trucks equipped with a leaded counterweight without a tow pin (see **Figure 29**).

If the lift truck is equipped with an LPG fuel system and is not in active use, close the fuel valve at the tank. If the lift truck is going to be left overnight or longer, the truck must be parked outside or the LPG tank must be removed and stored outside.

If the lift truck is transported in severe weather or any other condition that can damage the lift truck, cover the lift truck.



HYSTER

Maintenance

Make sure the protective cover is designed for the application and is securely fastened.

Unloading

If components normally attached to the lift truck were removed for transport, see the **Service Manual** for installation procedures.

1. If used, remove any protective cover.
2. Make sure the parking brake is applied.
3. Disconnect the straps or chains.
4. Remove the wheel blocks.
5. Check that all switches and accessories are turned **OFF**.
6. Unload the lift truck.

Preparation for Use

After being transported or stored, the lift truck must be prepared for use for proper operation. All problems must be corrected before use of the lift truck, see the **Service Manual** for procedures.

Preparation After Transport

1. Complete the unloading procedures.
2. Inspect the lift truck for damage and missing components.
3. Follow the steps in the section **How to Make Checks With the Engine Stopped**.



Maintenance

HYSTER

Maintenance Register

Protect your investment in materials handling equipment! Keep a high-residual value in your **Hyster** lift truck! Do the maintenance according to the **Maintenance Schedule** in this **Operating Manual**.

Your dealer for **Hyster** lift trucks has the equipment and trained service personnel to do a complete program of inspection, lubrication, and maintenance.

This **Maintenance Register** is used to record the time of each periodic inspection and maintenance. The dealer's stamp or authorized signature confirms that maintenance and inspection was done at regular intervals by authorized personnel.

1. Operating Hours _____ Date _____	2. Operating Hours _____ Date _____	3. Operating Hours _____ Date _____	4. Operating Hours _____ Date _____
5. Operating Hours _____ Date _____	6. Operating Hours _____ Date _____	7. Operating Hours _____ Date _____	8. Operating Hours _____ Date _____
9. Operating Hours _____ Date _____	10. Operating Hours _____ Date _____	11. Operating Hours _____ Date _____	12. Operating Hours _____ Date _____
13. Operating Hours _____ Date _____	14. Operating Hours _____ Date _____	15. Operating Hours _____ Date _____	16. Operating Hours _____ Date _____



HYSTER

Maintenance

17. Operating Hours _____ Date _____	18. Operating Hours _____ Date _____	19. Operating Hours _____ Date _____	20. Operating Hours _____ Date _____
21. Operating Hours _____ Date _____	22. Operating Hours _____ Date _____	23. Operating Hours _____ Date _____	24. Operating Hours _____ Date _____
25. Operating Hours _____ Date _____	26. Operating Hours _____ Date _____	27. Operating Hours _____ Date _____	28. Operating Hours _____ Date _____
29. Operating Hours _____ Date _____	30. Operating Hours _____ Date _____	31. Operating Hours _____ Date _____	32. Operating Hours _____ Date _____
33. Operating Hours _____ Date _____	34. Operating Hours _____ Date _____	35. Operating Hours _____ Date _____	36. Operating Hours _____ Date _____
37. Operating Hours _____ Date _____	38. Operating Hours _____ Date _____	39. Operating Hours _____ Date _____	40. Operating Hours _____ Date _____
41. Operating Hours _____ Date _____	42. Operating Hours _____ Date _____	43. Operating Hours _____ Date _____	44. Operating Hours _____ Date _____



NO MATTER HOW YOU SAY IT . . .

La Sécurité Ça Se Paye
La Seguridad Compensa
Betriebssicherheit Macht Sich Bezahlt
Passaa Oll Huolellinen
Veiligheid Voor Alles
Säkerhet Först
Essere Sicuro Paga
Seguranca Paga
Sikkerhet Først
Pinter Be Awas

सावधान और बिन्दा रहौ ।

في التاني السلامة

安全第一

**SAFETY
PAYS!**



OPERATING MANUAL

FORTENS

H6.0FT, H7.0FT (L006)

DO NOT REMOVE THIS MANUAL FROM THIS UNIT